



# s.80 NPT

3/4" - 2"  
gas cock with tamper  
proof lockwing



## Quality

- 24h 100% seal test guaranteed
- Dual sealing system allows valve to be operated in either direction making installation easier
- No metal-to-metal moving parts
- No maintenance ever required
- Cover clearly shows ball position
- Silicone-free lubricant on all seals
- Handle stops on body to avoid stresses at stem
- Chrome plated brass ball for longer life

## Body

- Hot forged sand blasted, unplated brass body and cap sealed with Loctite® or equivalent thread sealant
- Special design to combine newest technologies in valve and traditional gascock requirements
- Finest brass according to EN 12165 and EN 12164 specifications

## Stem

- Blowout-proof unplated brass stem
- Maintenance-free, double FPM O-rings at the stem for maximum safety

## Sealing

- Pure PTFE self-lubricating seats with flexible-lip design

## Threads

- NPT taper ANSI B.1.20.1 female by female threads

## Flow

- Full port to DIN 3357 for maximum flow

## Handle

- Hot forged brass tamper proof lockwing

## Working pressure & temperature

- 600 PSI (40 bar) non-shock cold working pressure
- 250 PSI (17 bar) non-shock working pressure for LP-Gas
- -40°F / +350°F (-40°C / +170°C)
- **WARNING:** freezing of the fluid in the installation may severely damage the valve

## Options

- Male by female NPT threads

## Upon request

- Painted gray

## Approved by or in compliance with

- Underwriters Laboratories (United States, Canada)
  - Guide YSDT: LP-Gas shut-off valve
  - Guide YRBX: Flammable liquid shut-off valve
  - Guide YRPV: Gas shut-off valve for use with natural and manufactured gases
  - Guide MHKZ: No. 6 oil at 250°F
- GOST-R (Russia)
- Canadian standards Association (United States, Canada)
- RoHS Compliant (EU)
- Kuwait Fire Service Directorate (Kuwait)

**NOTE:** approvals apply to specific configurations/sizes only.



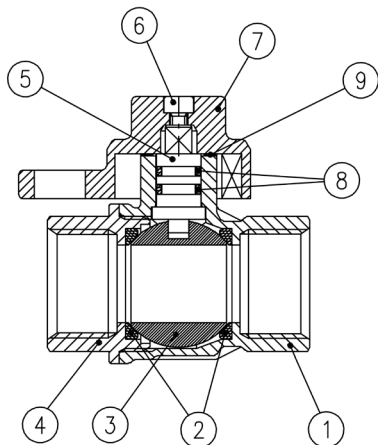

1 1/4"-2" hollow ball

Part description	Q.ty	Material
1	1	CW617N
2	2	PTFE
3	1	CW617N
4	1	CW617N
5	1	CW617N
6	1	1.4301 / AISI304
7	1	CW617N
8	2	FPM
9	1	PTFE glass filled 25%

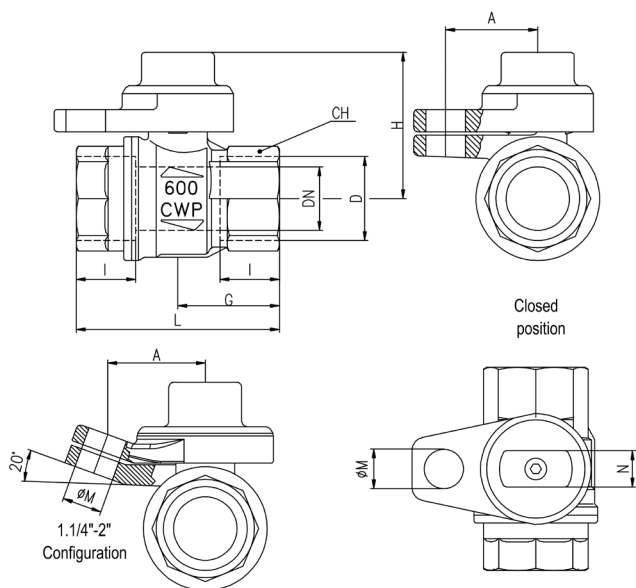

Code	S80E41	S80F41	S80G41	S80H41	S80I41
D (inch)	3/4	1	1 1/4	1 1/2	2
DN (inch)	0.787	0.984	1.259	1.574	1.968
I (inch)	0.669	0.826	0.905	0.905	1.043
L (inch)	2.519	3.188	3.661	4.015	4.763
G (inch)	1.259	1.594	1.830	2.007	2.381
A (inch)	1.142	1.142	1.208	1.208	1.208
H (inch)	1.801	1.958	2.519	2.756	3.031
M (inch)	0.492	0.492	0.472	0.472	0.472
N (inch)	0.449	0.449	0.563	0.563	0.563
CH (inch)	1.220	1.574	1.929	2.125	2.696
Cv (GPM)	48.5	80.9	92.4	144.4	206.8

DN shows the nominal flow diameter. Actual flow diameter complies with full port DIN 3357 part 4.

**Pressure-temperature chart**

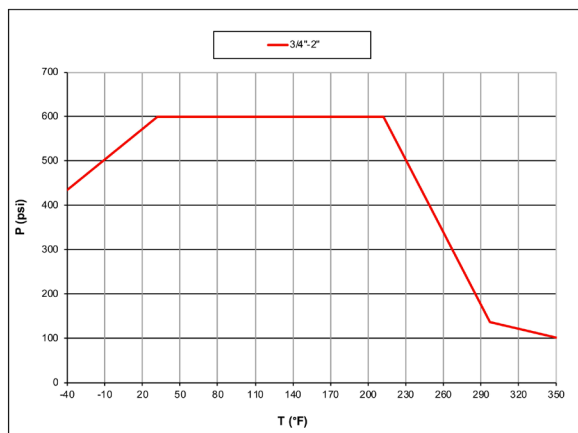

**Pressure drop chart**

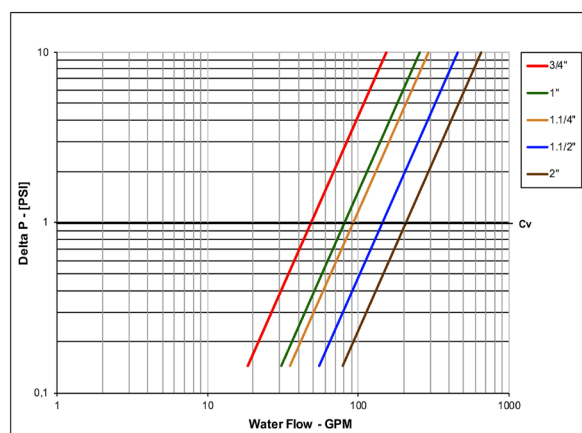

**WARNING:** This product can expose you to chemicals including lead which is known to the state of California to cause cancer and birth defects or other reproductive harm. For more information go to [www.P65Warnings.ca.gov](http://www.P65Warnings.ca.gov)

XCES80 - 4314