

C1600

The model **C1600** Hydraulic Squeeze Off Tool is designed to squeeze 12" to 16" MDPE and HDPE pipe safely and effectively.

The **C1600** features block stops for a variety of pipe sizes and SDR's, aircraft grade aluminum squeeze bars, chrome plated steel side shafts and a 10,000 PSI hydraulic system with quick connect fittings. This CNC machined tool contains no welded parts and exerts 261 tons of squeezing force.

The unique lock-in / swing-out bottom bar design allows for quick and easy access to the pipe, even in confined spaces, and the lock down bolts ensure that a squeeze is maintained even if the hydraulics are disconnected.

The **C1600** also incorporates an efficient dog bone design on the jaws to obtain maximum flow control, while requiring minimal force to squeeze the pipe.

The **C1600** also includes a standard grounding spike, and custom block stops are available upon request.

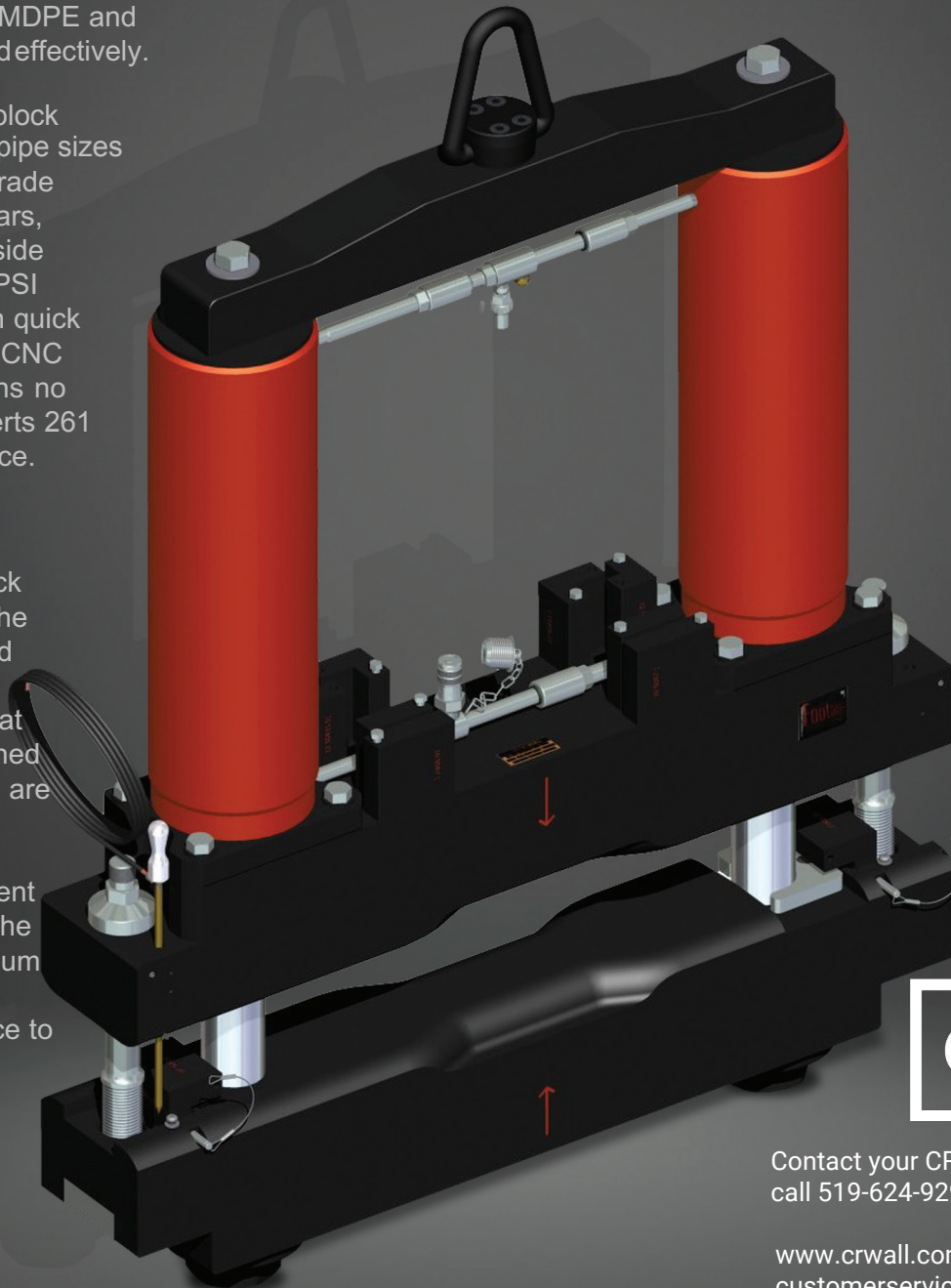

Contact your CR Wall Representative or call 519-624-9293 for more information

www.crwall.com | 519-624-9293
customerservice@crwall.com

For **12"** to **16"** PE & HDPE Pipe
1300lbs / Height 51.5" / Width 70"
Pump Required: Model C812S-AK1
ASTM Approved

Block Stop Options

12" (SDR 9, 11, 13.5)

14" (SDR 9, 11, 13.5)

16" (SDR 9, 11, 13.5)

Custom block stop available