

**FLWSIC500**  
**Ultrasonic Gas Flow Meter with**  
**Optional Volume Conversion**



**Installation**  
**Operation**  
**Maintenance**



## Document information

---

### Described product

Product name: FLOWSIC500

### Document ID

Title: Operating Instructions FLOWSIC500  
Part No.: 8015391  
Document ID: 9186957  
Version: 3-3  
Release: 2019-10

### Manufacturer

SICK Engineering GmbH  
Bergener Ring 27 · D-01458 Ottendorf-Okrilla · Germany  
Phone: +49 35205 52410  
Fax: +49 35205 52450  
E-mail: info.pa@sick.de

### Original documents

The English version 8015391 of this document is an original document from SICK Engineering GmbH.  
SICK Engineering GmbH assumes no liability for the correctness of an unauthorized translation.  
Please contact SICK Engineering GmbH or your local representative in case of doubt.

### Legal information

Subject to change without notice.

© SICK Engineering GmbH. All rights reserved.

## Glossary

---

|                        |  |
|------------------------|--|
| <b>AC</b>              | Alternating Current  |
| <b>Al</b>              | Aluminium  |
| <b>ATEX</b>            | ATEX: Atmosphères Explosifs: Abbreviation for European standards that govern safety in potentially explosive atmospheres   |
| <b>CSA</b>             | Canadian Standards Association ( <a href="http://www.csa.ca">www.csa.ca</a> )  |
| <b>DC</b>              | Direct Current   |
| <b>HF</b>              | High frequency, e. g. HF pulses  |
| <b>IEC</b>             | International Electrotechnical Commission  |
| <b>IECEX</b>           | IEC system for certification in accordance with standards for devices for use in potentially explosive atmospheres   |
| <b>IP<sub>xy</sub></b> | Ingress Protection: Degree of protection of a device in accordance with IEC/DIN EN 60529; x specifies the protection against contact and impurities, y protection against moisture.  |
| <b>LF</b>              | Low frequency, e. g. LF pulses   |
| <b>NAMUR</b>           | Abbreviation for "Normen-Arbeitsgemeinschaft für Mess- und Regeltechnik in der chemischen Industrie", now "Interessengemeinschaft Automatisierungstechnik der Prozessindustrie" ( <a href="http://www.namur.de">www.namur.de</a> ) |
| <b>pTZ</b>             | Volume conversion as a function of the pressure, the temperature and with consideration of the compression factor  |
| <b>TZ</b>              | Volume conversion as function of the temperature and a fixed pressure value and with consideration of the compression factor   |

## Warning symbols

---



IMMEDIATE HAZARD  
of severe injuries or death



Hazard (general)



Hazard by electrical voltage



Hazard in potentially explosive atmospheres



Hazard by explosive substances/mixtures



Hazard by unhealthy substances



Hazard by toxic substances

## Warning levels / signal words

---

### **DANGER**

Risk or hazardous situation which *will* result in severe personal injury or death.

### **WARNING**

Risk or hazardous situation which *could* result in severe personal injury or death.

### **CAUTION**

Hazard or unsafe practice which *could* result in less severe or minor injuries.

### **NOTICE**

Hazards which *could* result in property damage

## Information symbols

---



Information on product characteristics related to protection against explosions (general)



Information on product characteristics related to Explosion Protection Regulation (ATEX)



Information on product characteristics related to explosion protection in accordance with the IECEx scheme.



Important technical information for this product



Important information on electric or electronic functions



Nice to know



Supplementary information



Link referring to information at another place

|          |  |           |
|----------|--|-----------|
| <b>1</b> | <b>Important information</b>                   | <b>9</b>  |
| 1.1      | Main hazards                                   | 10        |
| 1.2      | About this document                            | 10        |
| 1.3      | Intended use                                   | 11        |
| 1.3.1    | Purpose of the device                          | 11        |
| 1.3.2    | Product identification                         | 11        |
| 1.3.3    | Operation in potentially explosive atmospheres | 12        |
| 1.3.4    | Combustible gas                                | 12        |
| 1.3.5    | Restrictions of use                            | 12        |
| 1.3.6    | Cleaning                                       | 13        |
| 1.4      | Responsibility of user                         | 13        |
| 1.5      | Additional documentation/information           | 14        |
| <b>2</b> | <b>Product description</b>                     | <b>15</b> |
| 2.1      | Measuring principle                            | 16        |
| 2.1.1    | Gas flow meter                                 | 16        |
| 2.1.2    | Volume conversion (optional)                   | 16        |
| 2.2      | System components                              | 17        |
| 2.2.1    | Adapter  | 17        |
| 2.2.2    | Gas flow meter                                 | 18        |
| 2.2.3    | Meter sizes                                    | 18        |
| 2.3      | FLOWgate™ operating software                   | 19        |
| 2.3.1    | Overview                                       | 19        |
| 2.3.2    | System requirements                            | 20        |
| 2.3.3    | Access rights                                  | 20        |
| 2.4      | Interfaces                                     | 21        |
| 2.4.1    | Pulse and status outputs                       | 21        |
| 2.4.2    | Encoder totalizer                              | 21        |
| 2.4.3    | Serial data interface                          | 21        |
| 2.4.4    | Optical data interface                         | 21        |
| 2.5      | Totalizers                                     | 22        |
| 2.5.1    | Device status and totalizers used              | 22        |
| 2.5.2    | Reverse flow                                   | 22        |
| 2.6      | Data processing in                             | 23        |
| 2.6.1    | Logbooks                                       | 23        |
| 2.6.2    | Archives                                       | 24        |
| 2.7      | Device option: Volume conversion               | 25        |
| 2.7.1    | Volume conversion                              | 25        |
| 2.7.2    | Integrated pressure and temperature sensors    | 26        |
| 2.7.3    | External pressure and temperature sensors      | 26        |
| 2.8      | Parameter protection                           | 28        |
| 2.8.1    | Parameter locking switch                       | 28        |
| 2.8.2    | Metrology logbook                              | 28        |
| 2.8.3    | Gas composition logbook                        | 30        |
| 2.9      | Sealing  | 31        |
| 2.10     | PowerIn Technology™                            | 33        |



|          |   |    |
|----------|---|----|
| <b>3</b> | <b>Installation</b>                                       | 35 |
| 3.1      | Hazards during installation                               | 36 |
| 3.2      | General information                                       | 36 |
| 3.2.1    | Delivery  | 36 |
| 3.2.2    | Transport   | 37 |
| 3.3      | Mechanical installation                                   | 37 |
| 3.3.1    | Preparations  | 37 |
| 3.3.2    | Choosing flanges, gaskets and other components            | 38 |
| 3.3.3    | Fitting in the pipeline                                   | 40 |
| 3.4      | Electrical installation                                   | 43 |
| 3.4.1    | Requirements for use in potentially explosive atmospheres | 43 |
| 3.4.2    | Criteria for electrical connection                        | 45 |
| 3.4.3    | Opening and closing the electronics cover                 | 45 |
| 3.4.4    | Rotating the control unit                                 | 46 |
| 3.4.5    | Electrical connections                                    | 47 |
| 3.4.6    | Pin assignment of plug-in connectors                      | 48 |
| 3.4.7    | DO configuration switch (Open Collector - Namur)          | 50 |
| 3.4.8    | Cable specifications                                      | 51 |
| 3.4.9    | Operation with external power supply                      | 52 |
| 3.4.10   | Battery operation   | 53 |
| 3.5      | Installing the external pressure and temperature sensors  | 54 |
| 3.5.1    | Fitting the plug-in connector cover                       | 54 |
| 3.5.2    | Installing the pressure sensor                            | 56 |
| 3.5.3    | Installing the temperature sensor                         | 60 |
| 3.6      | Fitting a display protector (option)                      | 60 |
| <b>4</b> | <b>Commissioning</b>                                      | 63 |
| 4.1      | General information                                       | 64 |
| 4.2      | Commissioning on the display                              | 64 |
| 4.2.1    | Commissioning sequence                                    | 64 |
| 4.2.2    | Setting the date and time                                 | 65 |
| 4.2.3    | Configuring volume conversion (device option)             | 65 |
| 4.2.4    | Checking the device status                                | 66 |
| 4.3      | Commissioning with the FLOWgate™ operating software       | 67 |
| 4.3.1    | Connect to the device                                     | 67 |
| 4.3.2    | Field setup wizard  | 68 |
| 4.3.3    | Activate and configure the daylight saving time           | 72 |
| 4.3.4    | Configure the power management                            | 73 |
| 4.3.5    | Function check after commissioning                        | 74 |

|          |   |           |
|----------|---|-----------|
| <b>5</b> | <b>Operation</b>                                      | <b>75</b> |
| 5.1      | Control unit  | 76        |
| 5.2      | Operating using the display                           | 76        |
| 5.2.1    | Display in the symbol bar                             | 77        |
| 5.2.2    | Battery fill level display                            | 77        |
| 5.2.3    | Main screen (without device option volume conversion) | 78        |
| 5.2.4    | Main display (with device option volume conversion)   | 80        |
| 5.2.5    | Configuration of main display                         | 84        |
| 5.2.6    | FLAWSIC500 menu                                       | 85        |
| 5.2.7    | Changing the user level                               | 90        |
| 5.2.8    | Setting the language                                  | 90        |
| 5.2.9    | Changing the device mode                              | 90        |
| 5.2.10   | Changing parameters                                   | 91        |
| 5.2.11   | Resetting the error volume                            | 91        |
| 5.2.12   | Resetting the event summary                           | 91        |
| 5.2.13   | Confirming battery replacement                        | 92        |
| 5.2.14   | Checking the external power supply                    | 92        |
| 5.2.15   | Testing the display                                   | 92        |
| <b>6</b> | <b>Clearing malfunctions</b>                          | <b>93</b> |
| 6.1      | Contacting Customer Service                           | 94        |
| 6.2      | Status messages                                       | 94        |
| 6.3      | Additional messages in the Event logbook              | 96        |
| 6.4      | Starting a diagnostic session                         | 97        |
| <b>7</b> | <b>Maintenance and meter exchange</b>                 | <b>99</b> |
| 7.1      | Information on handling lithium batteries             | 100       |
| 7.1.1    | Information on storage and transport                  | 101       |
| 7.1.2    | Disposal information                                  | 101       |
| 7.2      | Maintenance when using external power supply          | 102       |
| 7.2.1    | Service life of backup battery                        | 102       |
| 7.2.2    | Changing the backup battery                           | 102       |
| 7.3      | Maintenance when using battery power supply           | 103       |
| 7.3.1    | Service life of battery packs                         | 103       |
| 7.3.2    | Changing the battery packs                            | 103       |

|          |   |            |
|----------|---|------------|
| 7.4      | Meter exchange .....  | 105        |
| 7.4.1    | Prerequisites for meter exchange .....  | 105        |
| 7.4.2    | Hazards during meter exchange .....   | 105        |
| 7.4.3    | Sequence of meter exchange .....  | 105        |
| 7.4.4    | Required tools and auxiliary material .....   | 106        |
| 7.4.5    | Overview .....  | 107        |
| 7.4.6    | Backup of user-specific configuration of installed gas flow meter .....                     | 108        |
| 7.4.7    | Disconnecting electrical connections .....  | 109        |
| 7.4.8    | Removing the installed gas flow meter .....   | 110        |
| 7.4.9    | Installing the replacement gas flow meter .....   | 114        |
| 7.4.10   | Perform a leak tightness check .....  | 116        |
| 7.4.11   | Loading the parameter backup .....  | 119        |
| 7.4.12   | Checking the function of the new gas flow meter .....                                       | 123        |
| 7.4.13   | Securing metrologically .....   | 123        |
| 7.5      | Function check of a pressure or temperature sensor .....                                    | 124        |
| 7.6      | Exchanging an external pressure or temperature sensor .....                                 | 124        |
| 7.6.1    | Exchanging the pressure sensor .....  | 124        |
| 7.6.2    | Exchanging the temperature sensor .....   | 125        |
| <b>8</b> | <b>Accessories and spare parts .....</b>  | <b>127</b> |
| 8.1      | Accessories .....   | 128        |
| 8.1.1    | Gas flow meter accessories .....  | 128        |
| 8.1.2    | Volume conversion (device option) accessories .....   | 129        |
| 8.1.3    | Transport accessories .....   | 129        |
| 8.2      | Spare parts .....   | 130        |
| 8.2.1    | Gas flow meter spare parts .....  | 130        |
| 8.2.2    | Volume conversion (device option) spare parts .....   | 130        |
| <b>9</b> | <b>Annex .....</b>  | <b>131</b> |
| 9.1      | Conformities and Technical Data .....   | 132        |
| 9.1.1    | CE certificate .....  | 132        |
| 9.1.2    | Standards compatibility .....   | 132        |
| 9.1.3    | Technical Data .....  | 133        |
| 9.1.4    | Flow rates .....  | 135        |
| 9.1.5    | Overload protection .....   | 135        |
| 9.2      | Type code .....   | 136        |
| 9.3      | Type plates .....   | 138        |
| 9.3.1    | Metrology and electronics type plates .....   | 138        |
| 9.3.2    | Type plate, Pressure Equipment Directive .....  | 140        |
| 9.4      | Dimensional drawings .....  | 141        |
| 9.5      | Internal terminal assignment .....  | 142        |
| 9.6      | Installation examples .....   | 143        |
| 9.7      | Connection diagrams for operation of the FLOWSIC500 in accordance with CSA ..               | 146        |
| 9.8      | Connection diagrams for operation of the FLOWSIC500 in accordance with ATEX/<br>IECEX ..... | 153        |



# FLWSIC500

## 1 Important information

Main hazards  
About this document  
Intended use  
Responsibility of user  
Additional documentation/information

1.1 **Main hazards**

 **DANGER: Risk of explosion when the gas flow meter is damaged**  
 Natural gas flows with line pressure through the gas flow meter. Natural gas can escape when the gas flow meter is damaged which creates a risk of explosion.

- ▶ Prevent any possible damage to the gas flow meter. When necessary, fit protection devices.
- ▶ If the gas flow meter is damaged: Stop natural gas feed immediately and purge the FLOWSIC500 with inert gas.

 **WARNING: Hazards through leaks**  
 Operation in leaky condition is not allowed and potentially dangerous.

- ▶ Regularly check leak tightness of equipment.

1.2 **About this document**

This Manual describes:

- Device components
- Installation
- Operation of the FLOWSIC500.

It contains the main safety information for safe operation of the FLOWSIC500.

**Application area of the document**

 **NOTICE: Interface configurations**  
 This document is only valid for FLOWSIC500 with interface configurations F, G, H, I, J, K and L.

Make sure this document is valid for your FLOWSIC500:

- ▶ Check the type code, position 23 “I/O (Interface configurations)” on the type plate (→ Fig. 2) of your FLOWSIC500.
  - The FLOWSIC500 interface configurations F, G, H, I, J, K and L are described in this document.
  - Information on FLOWSIC500 with interface configurations A, B, C, D and E can be found in document “8018706, Addendum to Operating Instructions FLOWSIC500: Interface configurations”.

Fig. 1 Type code

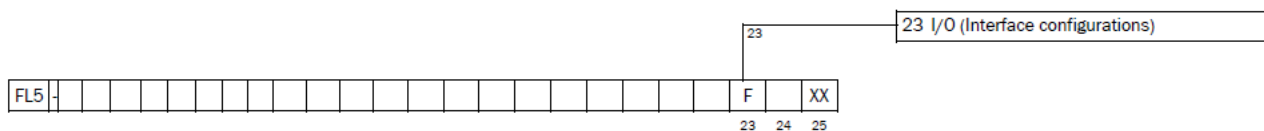

- ▶ For the complete type code description, see → p. 136, §9.2.

**FLOWSIC500 with Ex approval acc. CSA**

 **NOTICE:**  
 For a French translation of this document, please refer to document 8015392 "Manuel d'utilisation FLOWSIC500".

Subject to change without notice

1.3 **Intended use**

1.3.1 **Purpose of the device**

The FLOWSIC500 serves for measuring the gas volume, volume flow rate and gas velocity of natural gas in pipelines.

The FLOWSIC500 with optional volume conversion serves for measuring the gas volume and converting the gas volume measured to base conditions as well as registering data on totalizer levels, maximums and other data.

1.3.2 **Product identification**

|               |   |
|---------------|---|
| Product name: | FLAWSIC500  |
| Manufacturer: | SICK Engineering GmbH<br>Bergener Ring 27<br>01458 Ottendorf-Okrilla<br>Germany |

The type plates for metrological and electrical parameters are located on the gas flow meter. The type plate for the Pressure Equipment Directive is located on the adapter. Type plate examples, see → p. 138, §9.3.

Fig. 2 Location of type plates

**Marking according to ATEX/IECEx**

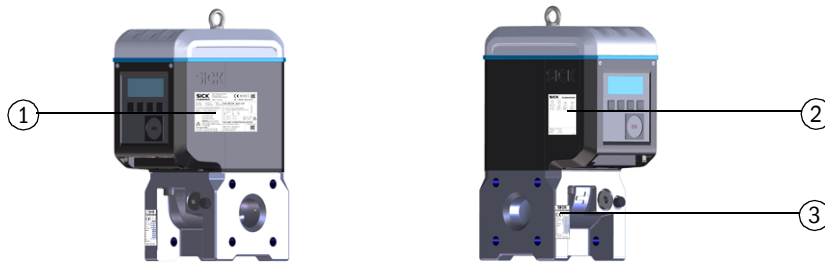

**Marking according to CSA**

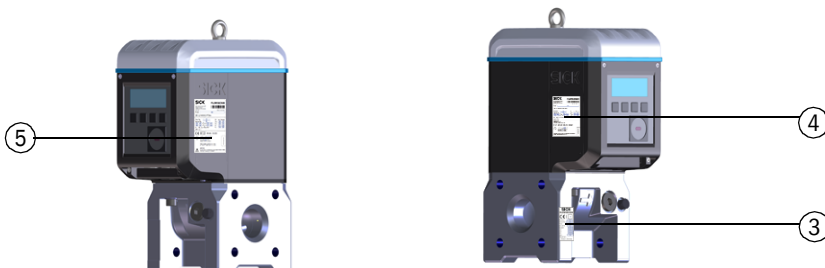

- 1 Type plate, metrological and electrical parameters (metrology and electronics)
- 2 Pin assignment of plug-in connectors
- 3 Type plate, Pressure Equipment Directive

- 4 Type plate, electrical parameters (electronics)
- 5 Type plate, metrological parameters (metrology)

### 1.3.3 Operation in potentially explosive atmospheres



The FLOWSIC500 is suitable for use in potentially explosive atmospheres:  
 ATEX: II 2G Ex ia [ia] IIB T4 Gb, II 2G Ex ia [ia] IIC T4 Gb, II 2G Ex op is IIC T4 Gb  
 IECEx: Ex ia [ia] IIB T4 Gb, Ex ia [ia] IIC T4 Gb, Ex op is IIC T4 Gb  
 US/C: Class I Division 1, Groups C, D T4, Ex/AEx ia IIB T4 Ga



Further information on potentially explosive atmospheres → p. 43, §3.4.1.

### 1.3.4 Combustible gas

- ▶ The FLOWSIC500 is suitable for measuring combustible and occasionally ignitable gases corresponding to zones 1 and 2.

### 1.3.5 Restrictions of use

- ▶ Refer to the type plate for the configuration of your FLOWSIC500.
- ▶ Check the FLOWSIC500 is suitably equipped for your application (e.g., gas conditions).



**WARNING:** Hazard through material fatigue

The FLOWSIC500 has been designed for use under mainly static loads.

- ▶ Maximum allowed gradient of static pressure: 3 bar/s (45 psi/sec)  
 The number of complete pressure application and release processes should be kept low during operation.
- ▶ Replace the device when 500 cycles have been reached.



**NOTICE:**

The FLOWSIC500 is designed for measuring clean and dry natural gas.

- ▶ The operating company should install a suitable filter or cone screen ahead of the gas flow meter when the gas is contaminated.



**NOTICE:**

- The FLOWSIC500 is suitable for use in pressurized lines within the parameters specified in the device. The device conforms to Pressure Device Equipment 2014/68/EC.
- It is the user's responsibility to ensure the maximum values specified for pressure and temperature on the type plate are not exceeded during operation.



1.3.6

**Cleaning**



**WARNING: Ignition hazard through electrostatic charges**

In certain extreme conditions in gas group IIC, unprotected plastic parts and non-grounded enclosure metal parts can reach an ignitable measure of electrostatic charges.

- ▶ Take precautionary measures to prevent electrostatic charges, localize, e.g. the components where a charge generating mechanism could occur (e.g. due to dust deposits caused by wind) and clean these with a damp cloth.



**NOTICE: Cleaning information**

- ▶ Only clean the FLOWSIC500 with a damp cloth.
- ▶ Do not use solvents for cleaning.
- ▶ Only use materials for cleaning which do not damage the surface of the FLOWSIC500.

1.4

**Responsibility of user**

- ▶ Only put the FLOWSIC500 into operation after reading the Operating Instructions.
- ▶ Observe all safety information.
- ▶ If anything is not clear: Please contact the SICK Customer Service.

**Designated users**

The FLOWSIC500 may only be operated by skilled technicians who, based on their technical training and knowledge as well as knowledge of the relevant regulations, can assess the tasks given and recognize the hazards involved.



**NOTICE:**

Skilled persons are persons in accordance with DIN VDE 0105 or IEC 364, or directly comparable standards.

These persons must have exact knowledge on hazards arising from operation, e.g. through hot, toxic, explosive gases or gases under pressure, gas-liquid mixtures or other media as well as adequate knowledge of the measuring system gained through training.



**Correct use**

- ▶ Only use the FLOWSIC500 as described in these Operating Instructions (→ p. 11, § 1.3.1). The manufacturer bears no responsibility for any other use.
- ▶ Do not carry out any work or repairs on the FLOWSIC500 not described in this manual.
- ▶ Do not remove, add or change any components in or on the FLOWSIC500 unless such changes are officially allowed and specified by the manufacturer.

Otherwise

- Any warranty by the manufacturer becomes void
- The FLOWSIC500 can become dangerous
- The approval for use in potentially explosive atmospheres is no longer valid
- The approval for use in lines pressurized above 0.5 bar (7.25 psi) bar is no longer valid.

**Danger identification on device**

|   |   |
|---|---|
|  | <p><b>WARNING: Danger identification on device</b></p> <p>The following symbol draws attention to important dangers directly on the device:</p> <p style="text-align: center;">  </p> <p>▶ Consult the Operating Instructions in all cases where the symbol is attached to the device or shown on the display.</p> |
|---|---|

**Special local conditions**

- ▶ Follow all local laws, regulations and company-internal operating directives applicable at the installation location.

**Retention of documents**

These Operating Instructions must be

- ▶ Kept available for reference
- ▶ Passed on to new owners.

## 1.5

**Additional documentation/information**

Some parameter settings, device components and characteristics depend on the individual device configuration. This individual device configuration is described in the device documentation delivered with the device:

- Conformity Declaration
- Material certificate
- Inspection certificate
  - Device configuration sheet
  - Encoder test protocol (optional)
  - Low pressure calibration test protocol (optional)
  - Labels according to Pressure Equipment Directive 2014/68/EC, Annex 1 Part 3.3
- Printed Parameter report
- Product CD:
  - Operating Instructions
  - FLOWgate™ operating software
  - FLOWgate™ Software Manual
  - Certificates
  - Instructions/information for accessories
  - Calibration instructions
  - Modbus specification

# FLWSIC500

## 2 Product description

Measuring principle

System components

FLOWgate™ operating software

Interfaces

Totalizers

Data processing in

Device option: Volume conversion

Parameter protection

Sealing

PowerIn Technology™

## 2.1 Measuring principle

### 2.1.1 Gas flow meter

The FLOWSIC500 works according to the principle of ultrasonic transit time difference measurement.

Fig. 3 Functional principle

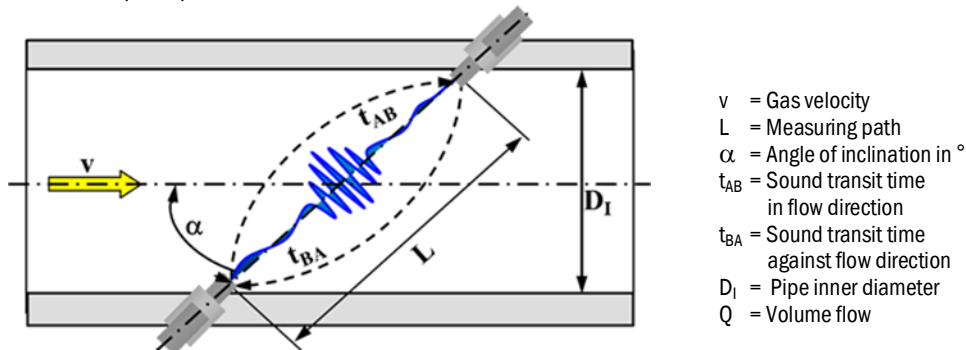

Measured signal transit times  $t_{AB}$  and  $t_{BA}$  are defined by the current sound and gas velocity. Gas velocity  $v$  is determined from the difference between the signal transit times. Therefore changes in the sound velocity caused by pressure or temperature fluctuations do not affect the calculated gas velocity with this measurement method.

The FLOWSIC500 calculates the volume flow rate internally from the gas velocity and the diameter of the measuring section of the gas flow meter.

$$Q = \frac{\pi D_I^2}{4} \cdot \frac{L}{2 \cos \alpha} \cdot \frac{t_{BA} - t_{AB}}{t_{AB} \cdot t_{BA}}$$

### 2.1.2 Volume conversion (optional)

The integrated volume conversion converts the measured gas volume from measurement conditions to base conditions.

Calculation according to EN 12405:

$$V_b = C \cdot V_m$$

$V_b$  = Volume at base conditions  
 $C$  = Conversion factor  
 $V_m$  = Volume at measurement conditions

$$C = \frac{p}{p_b} \cdot \frac{T_b}{T} \cdot \frac{Z_b}{Z}$$

$p$  = Gas pressure at measurement conditions  
 $p_b$  = Pressure at base conditions  
 $T$  = Gas temperature at measurement conditions  
 $T_b$  = Temperature at base conditions  
 $Z_b$  = Compression factor at base conditions  
 $Z$  = Compression factor at measurement conditions

The measurement conditions are either determined with pressure and temperature sensors or entered as fixed value.



The following short forms are used in this document for better readability:

- Volume at base conditions = base volume
- Volume at flowing conditions = measurement volume

## 2.2 System components

The FLOWSIC500 measuring system comprises:

- FLOWSIC500 gas flow meter,
- Adapter for installation in pipeline and
- Optional p&t sensors for the volume conversion device option.

Fig. 4 FLOWSIC500 components

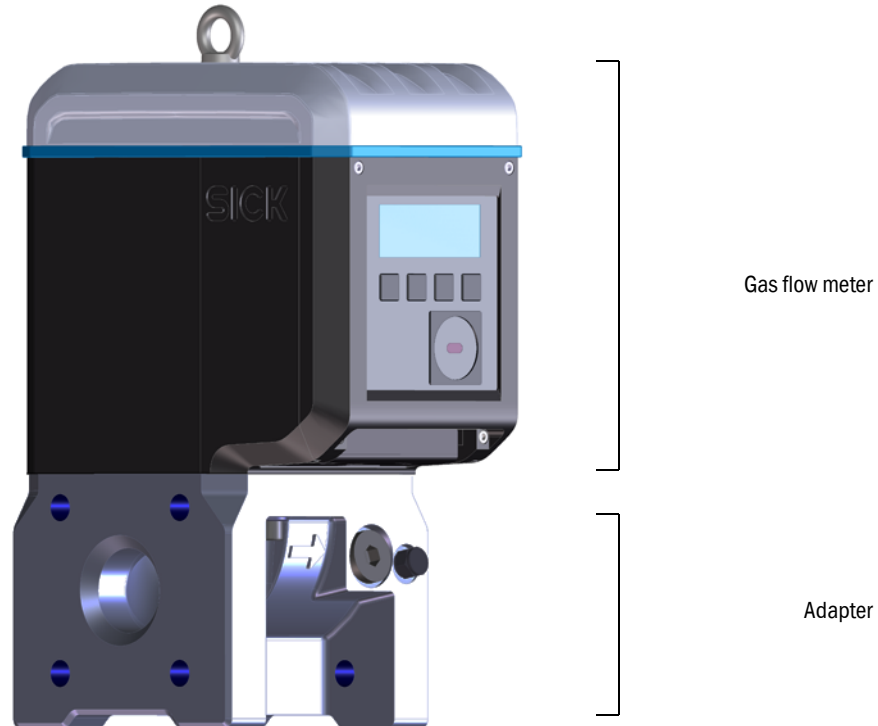

### 2.2.1 Adapter

The meter body is available in various flange standards and fitting lengths to connect the gas flow meter to the system pipeline.

Depending on the version, the adapter is designed for assembly on line flanges PN16 in accordance with DIN EN1092-1, CL150 in accordance with ASME B16.5, or 1.6MPa in accordance with GOST 12815-80.



Fitting lengths available: → p. 141, §9.4.

### 2.2.2 **Gas flow meter**

An internal flow conditioner rectifies the gas flow in the gas flow meter so that flow profile disturbances caused by pipe bends in the inlet or outlet sections or components projecting into the pipe (e.g., a thermowell) have no influence on measuring results.

The gas flow meter can be exchanged without taking the adapter out of the pipeline.

The gas flow meter is fitted with:

- Control unit
- Optical and electrical interfaces
- Measuring cell with ultrasonic transducers
- Electronics.

The product variant with volume conversion and integrated pressure and temperature sensors also has the calibrated pressure sensor and calibrated temperature sensor fitted in the gas flow meter.

### 2.2.3 **Meter sizes**

Available meter sizes → p. 141, §9.4.

## 2.3 FLOWgate™ operating software

The FLOWgate™ operating software allows user-friendly access to all measured values of the device.



For FLOWgate™ operating software, see “Software Manual FLOWgate™”. The Software Manual is on the delivered Product CD. The Software Manual is also available using the Help function of the FLOWgate™ operating software.

### 2.3.1 Overview

#### Software functions

- Measured values overview
- Field setup wizard
- Parameter modification
- Logbook and archive management
- Calibration
- Diagnostics data
- Service actions
- Session browser

Fig. 5 Software platform FLOWgate™ – FLOWSIC500 “Overview”

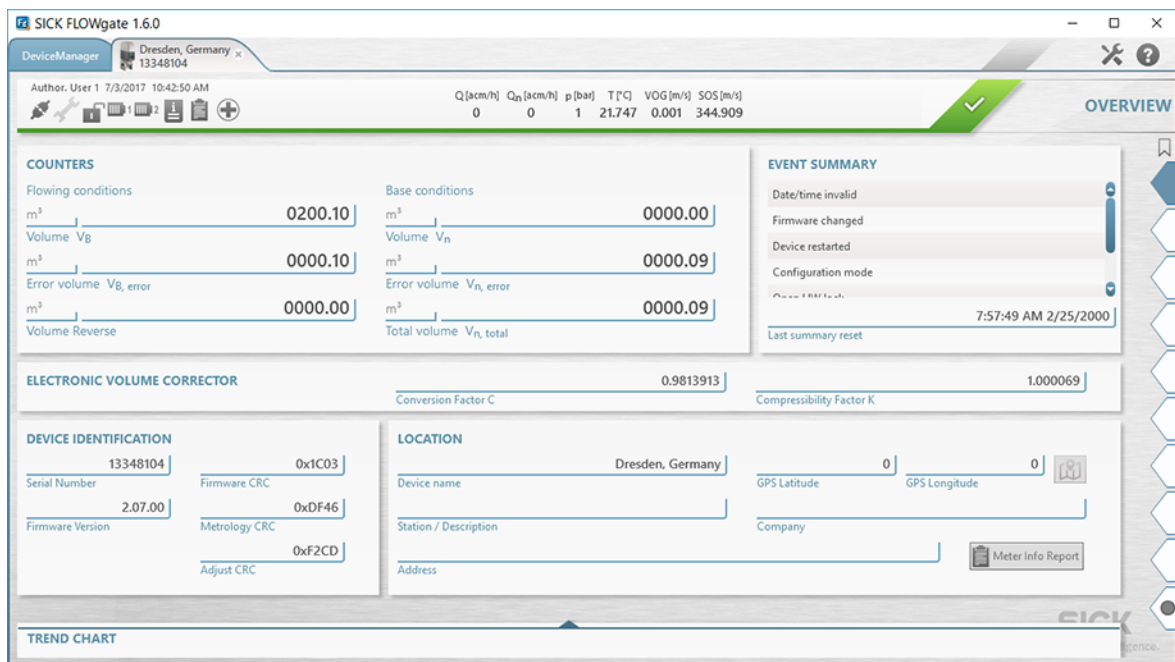

## 2.3.2

**System requirements**

- Microsoft Windows XP/7/8/10
- Min. 1 GHz CPU
- Min. 512 MB RAM
- Approx. 100 MB free memory (without .NET framework)
- USB or serial interface
- Recommended minimum screen resolution: 1024 x 768 pixels, optimum screen resolution 1368 x 768 pixels
- Microsoft .NET framework 4.0



If the user is not an administrator, the following entries in the registry must exist or be configured for installation of the system:

- AlwaysInstallElevated = 1
- EnableUserControl = 1

Support: [http://msdn.microsoft.com/en-us/library/aa367561\(v=vs.85\).aspx](http://msdn.microsoft.com/en-us/library/aa367561(v=vs.85).aspx)

## 2.3.3

**Access rights**

| Device function                        | Guest | User 3 | User 2 | User 1 | Auth. user 3 | Auth. user 2 | Auth. user 1 |
|--|-------|--------|--------|--------|--------------|--------------|--------------|
| Standard password                      | -     | 1111   | 1111   | 1111   | 2222         | 2222         | 2222         |
| User can be deactivated                | -     | x      | x      | -      | x            | x            | -            |
| Read parameters and measured values    | x     | x      | x      | x      | x            | x            | x            |
| Read data archive                      | -     | x      | x      | x      | x            | x            | x            |
| Change parameters not custody relevant | -     | x      | x      | x      | x            | x            | x            |
| Change custody relevant parameters     | -     | -      | -      | -      | x            | x            | x            |
| User management                        | -     | -      | -      | -      | -            | -            | x            |
| Calibration mode                       | -     | -      | -      | -      | x            | x            | x            |
| Configuration mode                     | -     | -      | -      | -      | x            | x            | x            |
| Test digital outputs                   | -     | -      | -      | -      | x            | x            | x            |



## 2.4 Interfaces

The FLOWSIC500 supports various digital and serial interfaces.

The configuration of the interfaces as delivered is described in the delivery documents provided with the respective device.

Table 1 Interface configurations

| Type code | I/O: F  | I/O: G      | I/O: H       | I/O: I or J | I/O: K       | I/O: L                       |
|-----------|---|-------------|--------------|-------------|--------------|------------------------------|
|           | LF  | HF          | Encoder + LF | RS485       | Encoder + HF | 2 x LF                       |
| DO_0      | -   | HF pulses   | Encoder      | -           | Encoder      | -                            |
| DO_1      | Normal operation: Diagnosis warning, test mode: Test pulses |             |              |             | HF pulses    | As for config. F, G, H, I, J |
| DO_2      | LF pulses   | -           | -            | -           | -            | LF pulses                    |
| DO_3      | Malfunction   | Malfunction | LF pulses    | -           | Malfunction  | LF pulses                    |
| Serial    | -   | -           | -            | RS485       | -            | -                            |



- Information on explosion-technical characteristics and rated voltage → p. 43, §3.4.
- Details on standard interface configurations available → p. 48, §3.4.6.

### 2.4.1 Pulse and status outputs

FLOWSIC500 has 4 digital switching outputs. Digital switching outputs DO\_0, DO\_2 and DO\_3 are electrically isolated according to EN 60947-5-6.

Alternatively, digital switching outputs DO\_2 and DO\_3 can also be configured as Open Collector.

When used as pulse output, maximum 2 kHz can be output on digital switching output DO\_0 and maximum 100 Hz on digital switching outputs DO\_2 and DO\_3. When used as status output, status information “Validity of measurement” or the result of the self-diagnosis can be represented.

Digital switching output DO\_1 is not electrically isolated. In normal mode, the diagnosis warning is output on DO\_1, test pulses are output in test mode.

The digital switching outputs are updated synchronously once per second.

### 2.4.2 Encoder totalizer

Alternatively, NAMUR switching output DO\_0 can be configured so that the totalizer level of the totalizer Vm, the meter state and a meter identification are output via asynchronous serial communication. This allows the connection of volume converters with a suitable input for encoder totalizers.



**NOTICE:**

With encoder communication, it must be ensured that the transmitted digit count or totalizer resolution can be processed by the connected volume converter.

A parameter modification can be carried out on the FLOWSIC500 with the FLOWgate™ operating software when the parameter locking switch is open.

### 2.4.3 Serial data interface

The serial interface is designed as externally powered RS485 and requires an external intrinsically safe power supply for operation.

### 2.4.4 Optical data interface

An optical interface according to IEC 62056-21 with serial bit, asynchronous data transmission is located on the front of the FLOWSIC500.

The interface can be used to read out data and parameter settings and to configure the FLOWSIC500.

## 2.5 Totalizers

### 2.5.1 Device status and totalizers used

Various volume totalizers are fitted on the FLOWSIC500 depending on the configuration. Meter V is used in the configuration as gas flow meter. If the gas flow meter has a malfunction, the measured volume is also recorded in the error volume counter errV.

Table 2 Device status and totalizers used

| Status      | Totalizer |      |
|-------------|-----------|------|
|             | V         | errV |
| Operation   | ●         |      |
| Malfunction | ●         | ●    |

A gas flow meter Vm, a base volume meter Vb and a total volume meter Vbtot are used in the configuration as gas flow meter with integrated volume conversion (device option). If malfunctions occur, the measured values are not recorded in the base volume meter Vb, but the converted volume is recorded in the malfunction volume encoder totalizer errVb.

Table 3 Device status and totalizers used (with device option volume conversion)

| Status      | Totalizer |       |       |    |       |
|-------------|-----------|-------|-------|----|-------|
|             | Vb        | errVb | Vbtot | Vm | errVm |
| Operation   | ●         |       | ●     | ●  |       |
| Malfunction |           | ●     | ●     | ●  | ●     |

Authorized users (user level “Authorized user”) can reset the error volume counters → p. 91, §5.2.11.

### 2.5.2 Reverse flow

The FLOWSIC500 is designed as unidirectional and has a configurable zero-flow cutoff which is factory set to a value of 1 m<sup>3</sup> (35 ft<sup>3</sup>) as default.

The totalizers are stopped during reverse flow and this volume is counted in a separate buffer totalizer. When normal operation resumes, the buffer totalizer is first computed with the flow rate.

The totalizers are first incremented again after the reverse flow volume has passed through.

During reverse flow, the meter first switches to malfunction when the preconfigured buffer volume has been exceeded. An error message is output on the device.

The zero-flow cutoff (measuring threshold for low flow rate) and the buffer volume (limit value for reverse flow volume) can be adjusted with the FLOWgate™ operating software during commissioning (→ p. 68, §4.3.2.3) or, after commissioning, in the “Warning” area in the “Parameter Modification” menu.

## 2.6 Data processing in

### 2.6.1 Logbooks

The FLOWSIC500 stores events and parameter changes in the following logbooks:

- Event logbook  
All events with timestamp, user logged on and totalizer level, max. number of entries: 1000  
When the Event logbook is 90% full, the FLOWSIC500 changes to device status “Warning”, warning W-2001 is shown on the display.  
When the Event logbook is full, the FLOWSIC500 changes to device status “Malfunction”, error E-3001 is shown on the display (→ p. 94, § 6.2, “Status messages”).
- Parameter logbook  
All parameter changes with timestamp, user logged on, totalizer level, old and new parameter value and register number, maximum number of entries: 250  
The oldest entries are overwritten when the Parameter logbook is full.
- Metrology logbook  
All changes to selected custody-relevant parameters (→ p. 28, § 2.8.2), with parameter locking switch activated with timestamp, user logged on, totalizer level, old and new parameter value and register number, maximum number of entries: 100  
When the Metrology logbook is full, custody relevant parameters can be modified only after the parameter locking switch has been opened. The FLOWSIC500 changes to device status “Warning”, warning W-2002 is shown on the display (→ p. 94, § 6.2, “Status messages”).
- Gas composition logbook  
All parameter changes of the gas composition for the volume conversion with timestamp, user logged on, totalizer level, old and new parameter values and register number, maximum number of entries: 150  
The oldest entries are overwritten when the Gas composition logbook is full.

The data are stored in non-volatile memory. All logbooks can be viewed, stored and reset with the FLOWgate™ operating software. The Event logbook can be viewed after logon as “User” or “Authorized user” on the device.

The following parameters are displayed:

- Event type
- Number of events
- Short description
- Timestamp

## 2.6.2

**Archives**

The integrated data registration stores totalizer levels, maximums and other data in the following archives:

- Measuring period archive  
Totalizers and data saved after the measuring period elapses (standard = 60 min.). The measuring period can be adjusted → p. 89, § 5.2.6.9.
- Daily archive  
Totalizers and data saved at the defined gas hour time (standard = 06:00)
- Monthly archive  
Totalizers and data saved at the defined gas day time (standard = 1st day of month)



Explanations on data structure and storage depth are available in Technical Bulletin “Data Registration”).

## 2.7 Device option: Volume conversion

### 2.7.1 Volume conversion

The FLOWSIC500 gas flow meter with volume conversion captures the gas volume under measurement conditions and converts it to a volume under base conditions.

Gas volume conversion can run selectively (set at the factory) as PTZ or TZ volume conversion. The configuration as temperature volume conversion uses the default value for measurement pressure for calculations.

Measurement conditions are recorded with the pressure and temperature sensors or entered as fixed values.

By default, measured values recording and subsequent calculation of the conversion factor are performed every 30 seconds. The update interval can be adjusted → p. 87, §5.2.6.5, "Calculation".

Depending on the configuration, the compressibility factor (K-factor) is determined with one of the following calculation methods or can be entered as a fixed value.

- Fixed value
- SGERG88
- AGA 8 Gross method 1
- AGA 8 Gross method 2
- AGA NX-19
- AGA NX-19 mod.
- AGA NX-19 mod. GOST
- GERG91 mod.
- AGA8-92DC (AGA-8 Detail)

The FLOWSIC500 checks the permissible entry limits of the parameters for the selected calculation method. If one of the entry values is outside the limit values, the FLOWSIC500 switches to malfunction state and uses the fixed value of the compressibility factor for calculation of the basis volume.

An absolute pressure sensor EDT 23 (optional: relative pressure sensor EDT 23) and a temperature sensor EDT 34 measure current measurement conditions and transfer the sensor type, measured value as well as the sensor status via a digital interface.

The FLOWSIC500 reads the valid measuring range automatically and, periodically, the current status and measured value.

A sensor is only activated for measurement when the configured serial number matches the serial number transferred for the sensor.

If no sensor is detected or a sensor is not functioning correctly, the FLOWSIC500 automatically uses the stored default value (= fixed value) of the state variable.

In this case, the FLOWSIC500 switches to malfunction state and, using the default value, stores the volume under base conditions calculated for pressure or temperature in the error volume counter.

If not specified otherwise, the FLOWSIC500 is supplied with the following standard settings:

Table 4 Standard settings

| Unit system  | SI                                       | Imperial                                  |
|--|--|---|
| T unit   | °C                                       | ° F                                       |
| P unit   | bar                                      | psi                                       |
| Symbols according to                               | EN 12405                                 | API                                       |
| Calculation method                                 | SGERG88                                  | AGA 8 Gross method 1                      |
| Reference conditions for density and heating value | (T1/T2/p2)<br>25 °C/0 °C/1.01325 bar (a) | (T1/T2/p2)<br>60 °F/60 °F/14.7300 psi (a) |

Table 4 Standard settings

| Unit system       | SI              | Imperial        |
|-------------------|-----------------|-----------------|
| Basic pressure    | 1.01325 bar (a) | 14.7300 psi (a) |
| Basic temperature | 0 °C            | 60 °F           |

### 2.7.2 Integrated pressure and temperature sensors

The FLOWSIC500 with volume conversion and integrated pressure and temperature sensors does not have any external components. The internal pressure and temperature sensors are already fitted and calibrated at the factory. The measuring ports are located in the gas flow meter.

This means the FLOWSIC500 does not require any additional installation of sensors to determine the measurement conditions and is immediately ready for operation after volume conversion has been configured.

### 2.7.3 External pressure and temperature sensors

The FLOWSIC500 with volume conversion and external sensors is used at measuring ports where a test/calibration of the pressure or temperature sensor in the system may be required.

It is recommended to install a three-way test valve that separates the pressure sensor from the measurement pressure and provides a test connection to test the pressure sensor.

→ Fig. 6 shows a FLOWSIC500 with external sensors and Kamstrup test valve BDA04 for gas temperatures to -25 °C.

Fig. 6 FLOWSIC500 with external sensors and Kamstrup test valve BDA04

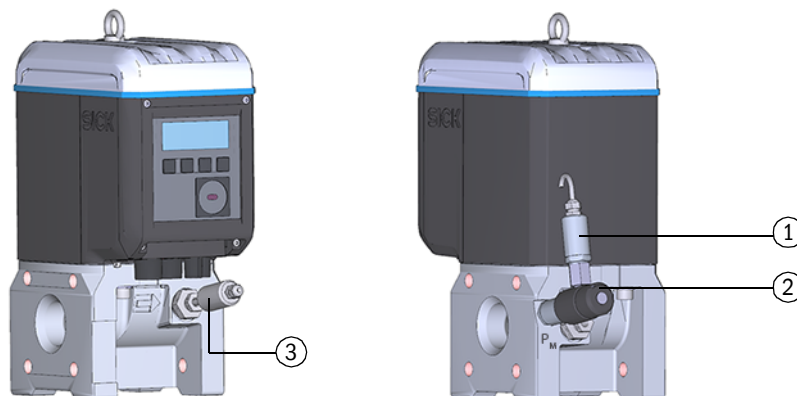

- 1 Pressure sensor
- 2 Kamstrup test valve BDA04
- 3 Temperature sensor

A three-way test valve (→ Fig. 7) that is fitted next to the FLOWSIC500 is used for gas temperatures to -40 °C.

Fig. 7

Three-way test valve with p-sensor and Minimes coupling

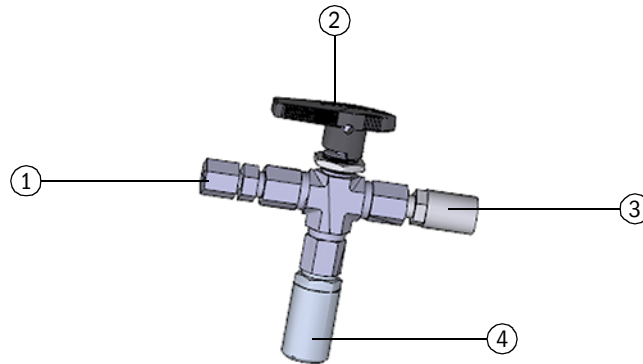

- 1 Pipe screw fitting 1/4" NPT on pipe D06  
or pipe screw fitting 1/4" NPT on pipe 1/4"
- 2 Hand lever
- 3 Test connection (Minimes coupling)
- 4 Pressure sensor, connection thread G 1/4"

## 2.8 Parameter protection

### 2.8.1 Parameter locking switch

A parameter locking switch is located on the circuit board to secure the custody relevant parameters. This covers all values that influence volume metering and volume conversion.

Fig. 8 Parameter locking switch on the circuit board

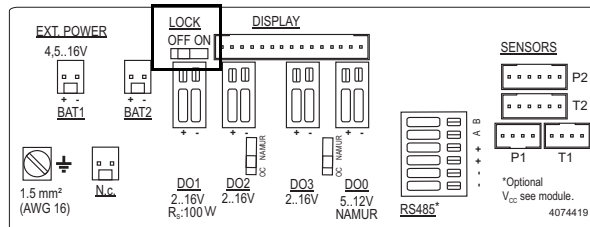

The parameter locking switch is secured by the terminal compartment cover and a seal.

### 2.8.2 Metrology logbook

Selected custody relevant parameters can be modified when the parameter locking switch is closed and after logging in as authorized user.

An entry in the metrology logbook is generated to ensure the traceability of these parameter changes. The entry contains the timestamp, old and new value, totalizer level V (for gas flow meters) or V<sub>b</sub> (for gas flow meters with device option volume conversion) and the logged on user.

The Metrology logbook can have a maximum of 100 entries. The FLOWSIC500 switches to status “Warning” when the Metrology logbook is full.

The Metrology logbook can be cleared when the parameter locking switch is open. Parameter changes to the following parameters are entered in the Metrology logbook as long as entries are possible.

Table 5 Custody relevant parameters - gas flow meter

| Parameter                           | Description                                   |
|-------------------------------------|---|
| Max. reverse flow volume            | Buffer volume for reverse flow                |
| Symbols for measured value displays | Symbols used on the display (formula symbols) |



Table 6 Custody relevant parameters - gas flow meter with volume conversion

| Parameter                           | Description   |
|-------------------------------------|---|
| Max. reverse flow volume            | Buffer volume for reverse flow  |
| Symbols for measured value displays | Symbols used on the display (formula symbols)   |
| Calculation interval                | Cycle time for updating measured values (pressure, temperature) and calculation of the compressibility factor |
| Calculation method                  | Calculation method for the compressibility factor   |
| Value range check                   | Checking the input parameters for the conversion algorithms   |
| Reference conditions                | Reference conditions for density and heating value  |
| Heating value unit                  | Heating value unit  |
| Density value selection             | Selection of relative density or standard density   |
| Basic pressure                      | Pressure standard conditions  |
| Basic temperature                   | Temperature standard conditions   |
| K-factor (fixed)                    | Figure for method "Fixed value" when the calculation of the K-factor is incorrect                             |
| Default value for Molar mass        | Default value, when the calculation of the molar mass is disturbed  |
| p Lower alarm limit                 | Lower warning limit for the pressure which can be set by the customer   |
| p Upper alarm limit                 | Upper warning limit for the pressure which can be set by the customer   |
| p Default value                     | Fixed value of measurement pressure   |
| p Unit                              | Unit for pressure values  |
| Atmospheric pressure                | Ambient pressure  |
| p Serial number                     | Serial number of pressure sensor  |
| p Offset                            | Offset for pressure sensor adjustment   |
| p Adjust factor                     | Factor for pressure sensor adjustment   |
| T Lower alarm limit                 | Lower warning limit for the temperature which can be set by the customer                                      |
| T Upper alarm limit                 | Upper warning limit for the temperature which can be set by the customer                                      |
| T Default value                     | Fixed value of measurement temperature  |
| T Unit                              | Unit for temperature values, used for entry and display   |
| T Serial number                     | Serial number of temperature sensor   |
| T Offset                            | Offset for temperature sensor adjustment  |
| T Adjust factor                     | Factor for temperature sensor adjustment  |
| Measuring period                    | Period for billing archive  |
| Gas hour                            | Billing hour for the day archive  |
| Gas day                             | Billing day for month archive   |
| Flow rate - upper warning limit     | Lower warning limit for the flow rate which can be set by the customer  |
| Flow rate - lower warning limit     | Upper warning limit for the flow rate which can be set by the customer  |

### 2.8.3 Gas composition logbook

All changes of gas composition parameters for volume conversion are saved in the Gas composition logbook.

The entry contains timestamp, old and new value of the changed parameter, totalizer level Vb, logged on user and the register number. The Gas composition logbook can have a maximum of 150 entries. The oldest entries are overwritten when the Gas composition logbook is full.

The Gas composition logbook can only be cleared when the parameter locking switch is open.

Table 7 Gas composition parameters for volume conversion

| Parameter                            | Description   |
|--------------------------------------|---|
| Relative density                     | Relation between gas density and air density under reference conditions |
| Reference density                    | Gas reference density under reference conditions                        |
| Heating value                        | Gas heating (under reference conditions)                                |
| Carbon dioxide (CO <sub>2</sub> )    | CO <sub>2</sub> proportion in gas                                       |
| Hydrogen H <sub>2</sub>              | H <sub>2</sub> proportion in gas  |
| Nitrogen N <sub>2</sub>              | N <sub>2</sub> proportion in gas  |
| Methane CH <sub>4</sub>              | Methane proportion in gas   |
| Ethane C <sub>2</sub> H <sub>6</sub> | Ethane proportion in gas  |
| Propane                              | Propane proportion in gas   |
| Water H <sub>2</sub> O               | Water vapor proportion in gas   |
| Hydrogen sulfide H <sub>2</sub> S    | Hydrogen sulfide proportion in gas                                      |
| Carbon monoxide CO                   | Carbon monoxide proportion in gas                                       |
| Oxygen O <sub>2</sub>                | Oxygen proportion in gas  |
| i-butane                             | i-butane proportion in gas  |
| n-butane                             | n-butane proportion in gas  |
| i-pentane                            | i-pentane proportion in gas   |
| n-pentane                            | n-pentane proportion in gas   |
| n-hexane                             | Hexane proportion in gas  |
| n-heptane                            | Heptane proportion in gas   |
| n-octane                             | Octane proportion in gas  |
| n-nonane                             | Nonane proportion in gas  |
| n-decane                             | Decane proportion in gas  |
| Helium                               | Helium proportion in gas  |
| Argon                                | Argon proportion in gas   |

## 2.9

**Sealing**

The FLOWSIC500 is secured at the factory with a seal on the cover.

Gas flow meter and adapter can be secured at the joint by a user seal (adhesive label) glued with approximately equal spread on gas flow meter and adapter.

Optionally, the electronics cover can also be protected by the customer after the end of the installation against unauthorized opening.

Fig. 9

Factory seal of the cover on the gas flow meter

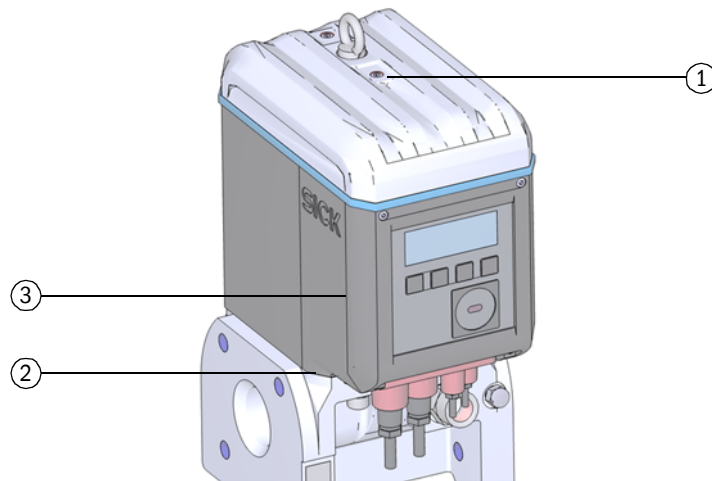

- 1 Seal position
- 2 Possible position of the adapter seal
- 3 Possible position of the electronic cover seal

In addition, the FLOWSIC500 has seal positions on the terminal compartment cover and the plug-in connector cover.

An adhesive label secures the interfaces and the parameter lock by the terminal cover compartment.

During commissioning, the plug-in connector cover must be secured according to national regulations. This can be performed with an adhesive label which is glued with approximately equal spread on the cover and the enclosure or alternatively by using capstan screws and a tensioned sealing wire and a wire seal.

Fig. 10

Seals on the terminal compartment and plug-in connector cover

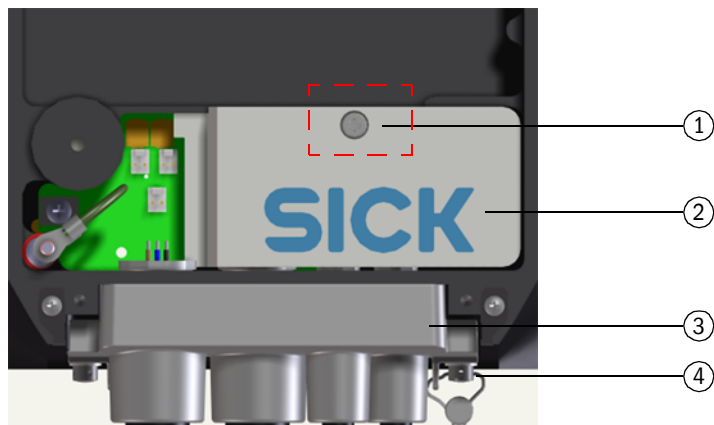

- 1 Seal position
- 2 Terminal compartment cover (securing the terminal compartment)
- 3 Plug-in connector cover
- 4 Capstan screw, wire and wire seal (securing of plug-in connector cover)

**NOTICE:**

- ▶ Secure the terminal compartment cover and the plug-in connector cover with at least one verification seal against unauthorized removal of the cover!

Fig. 11

Seal on the temperature sensor (example)

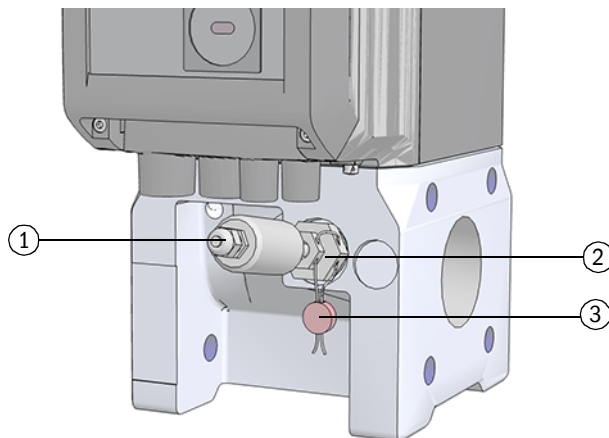

- 1 Temperature sensor
- 2 Locknut
- 3 Wire seal

Fig. 12 Seal on the pressure sensor (example)

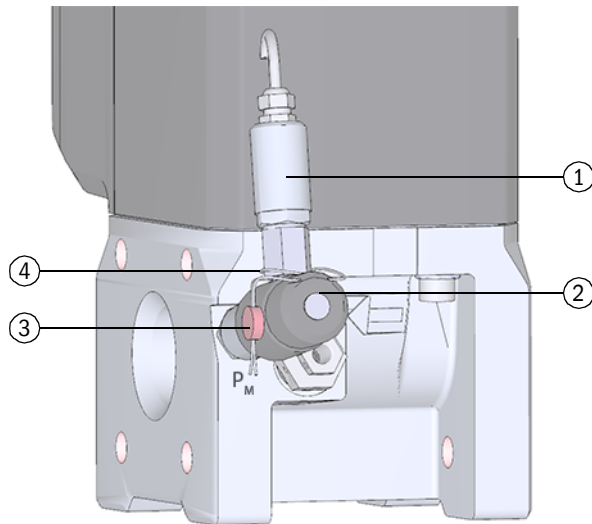

- 1 Pressure sensor
- 2 Kamstrup test valve BDA04
- 3 Wire seal
- 4 Wire loop



**NOTICE:**

Make sure that the wire loop is placed tight around the pressure sensor.

2.10

**PowerIn Technology™**

The FLOWSIC500 is available with two configurations:

- For operation with external intrinsically safe power supply with backup battery (backup duration: Approx. 3 months).
- Self-sufficient power configuration: 2 internal longlife battery packs (typical service life: At least 5 years).

The second battery pack is activated automatically when the first pack is empty and a message displayed (→ p. 76, §5.2).

Subject to change without notice

# FLWSIC500

## 3 Installation

Hazards during installation

General information

Mechanical installation

Electrical installation

Installing the external pressure and temperature sensors

### 3.1 Hazards during installation



#### **CAUTION: General risks during installation**

- ▶ Observe applicable valid regulations, general standards and guidelines.
- ▶ Observe local safety regulations, operating instructions and special regulations.
- ▶ Observe the safety information in → p. 10, §1.1.
- ▶ Comply with the safety requirements of Pressure Equipment Directive 2014/68/EC or ASME B31.3 when installing pressure devices including connection of various pressure devices.
- ▶ Persons carrying out installation work must be familiar with the directives and standards applicable for pipeline construction and have the corresponding qualifications, e.g. in accordance with DIN EN 1591-4.



#### **WARNING: Hazards through the gas in the system**

The following conditions can increase the risk:

- Toxic gas or gas dangerous to health
- Explosive gas
- High gas pressure
- ▶ Only carry out installation, maintenance and repair work when the system is non-pressurized.



#### **WARNING: Hazards during installation work**

- ▶ Do not carry out any welding work on lines with meters fitted.
  - ▶ Comply exactly with mandatory and approved methods.
  - ▶ Observe and comply with regulations of the plant operator.
  - ▶ Meticulously check completed work. Ensure leak tightness and strength.
- Otherwise hazards are possible and safe operation is not ensured.

### 3.2 General information

#### 3.2.1 Delivery

The FLOWSIC500 is delivered preassembled in sturdy packaging.

- ▶ Inspect for transport damage when unpacking the device.
- ▶ Document any damage found and report this to the manufacturer.



#### **NOTICE:**

Do not put the FLOWSIC500 into operation if you notice any damage!

- ▶ Check the scope of delivery for completeness.

#### **The standard scope of delivery comprises:**

- FLOWSIC500 (gas flow meter and adapter, already fitted),
- Backup battery (if device is configured for external power supply), or
- 2 battery packs (if device is configured for battery operation).



### 3.2.2 Transport

- ▶ During all transport and storage work, ensure:
  - The FLOWSIC500 is always well secured
  - Measures to prevent mechanical damage have been taken
  - Ambient conditions are within specified limits.

### 3.3 Mechanical installation



#### **CAUTION: General risks during installation**

- ▶ Observe applicable valid regulations, general standards and guidelines.
- ▶ Observe local safety regulations, operating instructions and special regulations.
- ▶ Observe the safety information in → p. 10, § 1.1.
- ▶ Comply with the safety requirements of Pressure Equipment Directive 2014/68/EC or ASME B31.3 when installing pressure devices including connection of various pressure devices.
- ▶ Persons carrying out installation work must be familiar with the directives and standards applicable for pipeline construction and have the corresponding qualifications, e.g. in accordance with DIN EN 1591-4.

The FLOWSIC500 normally does not need straight inlet and outlet sections and can be fitted directly after bends in the pipe.



#### **NOTICE: Installation requirements**

- ▶ The following elements must not be present within a distance of 5 DN to the adapter in upstream direction:
  - A valve not always operated fully open,
  - a pressure regulator.
- ▶ The pressure sensor must be maximum 5 DN behind the gas flow meter. Alternatively, the temperature sensor in the optional immersion sleeves can be used in the adapter.
- ▶ In concrete application, observe limitations resulting from type approval!

### 3.3.1 Preparations

- ▶ Select a suitable installation location. Ensure adequate assembly clearances (→ Table 10).
- ▶ The following tools and materials are required to install the FLOWSIC500:
  - Hoisting equipment (lifting capacity according to the weight specifications → p. 141, §9.4)
  - Box wrench with size suitable for flange installation
  - Torque wrench
  - Flange gaskets
  - Lubricant, metal-free or suitable for aluminum, e.g. OKS 235, to prevent thread mountings seizing up.



#### **NOTICE:**

Do not use copper paste!

- SW3 Allen key
- Leak detection.

### 3.3.2 Choosing flanges, gaskets and other components

For flange connections only use pipeline flanges, bolts, nuts and gaskets suitable for the maximum operating pressure, maximum operating temperature as well as ambient and operating conditions (external and internal corrosion).

→ Table 8 contains a list of recommended bolts and → Table 9 contains a list of recommended gaskets.

Table 8 Bolts and tightening torques

| Device/flange type        | Bolts   | Washers   | Nuts   | Tightening torque |            |
|---------------------------|---|---|--|-------------------|------------|
| PN16 / EN1092-1           |   |   |  |                   |            |
| DN50/ PN16                | 4 pc. DIN835-M16x45-A2-70   | 4 pc. DIN125-A17-A4   | 4 pc. ISO4032-M16-A4-70  | 130 Nm            | 96 lbf ft  |
| DN80/ PN16<br>DN100/ PN16 | 8 pc. DIN835-M16x45-A2-70   | 8 pc. DIN125-A17-A4   | 8 pc. ISO4032-M16-A4-70  | 130 Nm            | 96 lbf ft  |
| DN150/ PN16               | 8 pc. DIN835-M16x45-A2-70   | 8 pc. DIN125-A21-A2   | 8 pc. ISO4032-M20-A2-70  | 250 Nm            | 184 lbf ft |
| Class 150 / ASME B16.5    |   |   |  |                   |            |
| 2" / CI150                | 4 pc. Double end threaded stud Ø 5/8", length 3.5" - ASME B18.31.2, ASTM A193 Grade B8M | 4 pc. Type A plain washer (narrow series) Ø 5/8" - ANSI B18.22.1, grade 8 stainless steel | 4 pc. Hex flat nut (UNC series) Ø 5/8" - ANSI B18.2.2, ASTM A194 Grade 8MA | 140 Nm            | 103 lbf ft |
| 3" / CI150                |   |   |  |                   |            |
| 4" / CI150                | 8 pc. Double end threaded stud Ø 5/8", length 3.5" - ASME B18.31.2, ASTM A193 Grade B8M | 8 pc. Type A plain washer (narrow series) Ø 5/8" - ANSI B18.22.1, grade 8 stainless steel | 8 pc. Hex flat nut (UNC series) Ø 5/8" - ANSI B18.2.2, ASTM A194 Grade 8MA | 140 Nm            | 103 lbf ft |
| 6" / CI150                | 8 pc. Double end threaded stud Ø 3/4", length 4.0" - ASME B18.31.2, ASTM A193 Grade B8M | 8 pc. Type A plain washer (narrow series) Ø 3/4" - ANSI B18.22.1, grade 8 stainless steel | 8 pc. Hex flat nut (UNC series) Ø 3/4" - ANSI B18.2.2, ASTM A194 Grade 8MA | 240 Nm            | 177 lbf ft |

Table 9 Gaskets

| Device/flange type     | Da <sup>[1]</sup> [mm] | Di [mm] | S [mm] | Material                |
|------------------------|------------------------|---------|--------|-------------------------|
| PN16 / EN1092-1        |                        |         |        |                         |
| DN50/ PN16             | 107                    | 61      | 2      | novapress® FLEXIBLE/815 |
| DN80/ PN16             | 142                    | 90      |        |                         |
| DN100/ PN16            | 162                    | 115     |        |                         |
| DN150/ PN16            | 218                    | 169     |        |                         |
| Class 150 / ASME B16.5 |                        |         |        |                         |
| 2" / CI150             | 105                    | 60      | 2      | novapress® FLEXIBLE/815 |
| 3" / CI150             | 137                    | 89      |        |                         |
| 4" / CI150             | 175                    | 114     |        |                         |
| 6" / CI150             | 222                    | 168     |        |                         |

[1] Da = outer diameter, Di = inner diameter, S = thickness, → Fig. 13

Fig. 13 Dimensions of gaskets

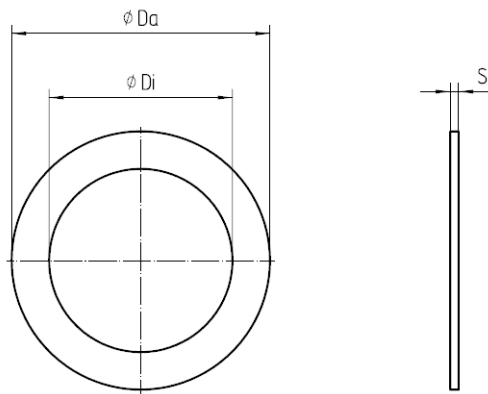

### 3.3.3 Fitting in the pipeline



**NOTICE:**

- The lifting lug is designed for transporting the measuring device only.  
Do not lift or transport the FLOWSIC500 with additional loads using this lug.
- ▶ The FLOWSIC500 must not swing or tilt on the hoisting equipment during transport.
  - ▶ The FLOWSIC500 must not turn during transport otherwise the lifting lug could be screwed out.



**NOTICE: Observe the gas flow direction**

- The prescribed flow direction is marked on the adapter with an arrow.  
Arrow direction and gas flow direction must match.
- ▶ Install the FLOWSIC500 in flow direction.  
The device signals a malfunction when the FLOWSIC500 is installed against the prescribed flow direction.

The FLOWSIC500 can be installed horizontal or vertical.  
The control unit can be rotated  $\pm 90^\circ$  ( $\rightarrow$  p. 46, §3.4.4).

Fig. 14

Installation examples

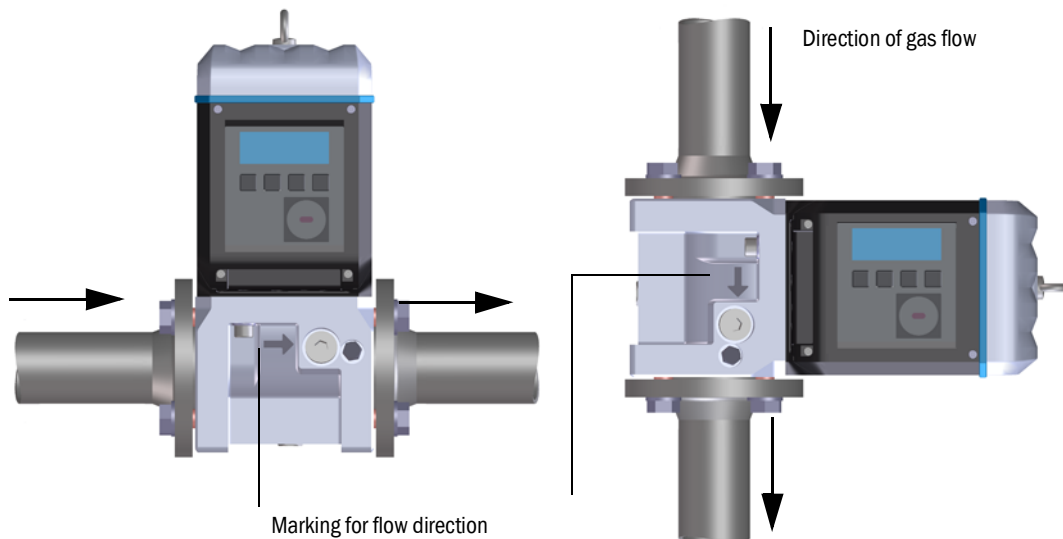

3.3.3.1 **Assembly clearances**

Maintain adequate assembly clearances to ensure there is enough room to exchange the gas flow meter. The upward clearance is needed to remove the gas flow meter from the adapter and to put it back on again. The downward clearance is needed to loosen the screws, take these out or insert these again and to fit the tool correctly.

|   |   |
|---|---|
|  | <p><b>NOTICE:</b><br/>Depending on the tool used and the installation location, adequate clearances to the sides are also required.</p> |
|---|---|

Fig. 15 Assembly clearances



- 1 Upward clearance
- 2 Downward clearance

Table 10 Minimum clearance required starting from the pipe axis

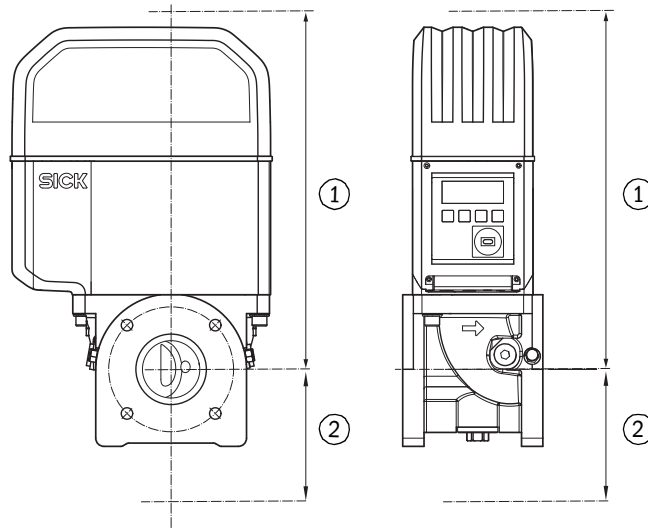
| Meter size | Upward clearance, without lifting lug |       | Upward clearance, with lifting lug |       | Downward clearance |      |
|------------|---------------------------------------|-------|------------------------------------|-------|--------------------|------|
|            | [mm]                                  | [in]  | [mm]                               | [in]  | [mm]               | [in] |
| DN50/2"    | 300                                   | 11,81 | 340                                | 13,39 | 200                | 7,87 |
| DN80/3"    | 460                                   | 18,11 | 510                                | 20,08 | 250                | 9,84 |
| DN100/4"   | 520                                   | 20,47 | 570                                | 22,44 | 320                | 12,6 |
| DN150/6"   | 520                                   | 20,47 | 570                                | 22,44 | 320                | 12,6 |

3.3.3.2 **Pipeline torque**

|   |   |
|---|---|
|  | <p><b>NOTICE:</b><br/>If the FLOWVIC500 is installed so that the gas flow meter projects sideways from the pipeline, the gas flow meter weight creates a torque on the pipeline.<br/>► Make sure the pipeline is capable of holding the gas flow meter → p. 41, Table 11.</p> |
|---|---|

Table 11 Pipeline torque

| Meter size | Torque |          |
|------------|--------|----------|
|            | [Nm]   | [lbf ft] |
| DN50/2"    | 6      | 5        |
| DN80/3"    | 16     | 12       |
| DN100/4"   | 31     | 23       |
| DN150/6"   | 31     | 23       |

Subject to change without notice

## 3.3.3.3

**Installation in pipeline**

- 1 Select suitable bolts.  
Recommended bolts → Table 8.
- 2 Use the hoisting equipment to position the FLOWSIC500 in the desired location in the pipeline.  
Lay the pipelines without tension to the device to be installed!
- 3 Insert and align the gaskets.
- 4 Apply lubricant to the bolts.
- 5 First screw the bolts by hand into the adapter to the stop.
  - Screw in the bolts according to DIN835 with the shorter thread end.
  - The bolts according to ASME B18.31.2 can be screwed in with any end.
- 6 Check the thread length in the adapter is fully utilized.
- 7 Then install the washers and nuts, and tighten them by hand.
- 8 Check whether the thread length of the nut is fully utilized.  
If necessary, use a different bolt length.
- 9 Check correct positioning of flange gaskets.
- 10 Tighten nuts evenly and crosswise in small steps until the specified tightening torque is reached (→ Table 8).  
Make sure the flange sits free of tension.
- 11 Slowly increase the pressure in the pipeline.  
Gradient: Max. 3 bar/min (45 psi/min)
- 12 Carry out a leak tightness check on the pipeline (in accordance with the pipeline operating company's specifications).

### 3.4 Electrical installation

#### 3.4.1 Requirements for use in potentially explosive atmospheres



The FLOWSIC500 is suitable for use in potentially explosive atmospheres:  
 ATEX: II 2G Ex ia [ia] IIB T4 Gb, II 2G Ex ia [ia] IIC T4 Gb, II 2G Ex op is IIC T4 Gb  
 IECEx: Ex ia [ia] IIB T4 Gb, Ex ia [ia] IIC T4 Gb, Ex op is IIC T4 Gb  
 US/C: Class I Division 1, Groups C, D T4, Ex/AEx ia IIB T4 Ga



For a FLOWSIC500 used in potentially explosive atmospheres:

- ▶ Installation, commissioning, maintenance and inspection may only be carried out by skilled persons having knowledge of the relevant rules and regulations for potentially explosive atmospheres, especially:
  - Ignition protection types
  - Installation regulations
  - Category classification
- ▶ Comply with all valid IEC standards.

The FLOWSIC500 is suitable for measuring combustible and occasionally ignitable gases corresponding to zones 1 and 2.

#### Basic requirements

- ▶ The documentation for zone categorization in accordance with IEC60079-10 must be available
- ▶ The FLOWSIC500 must have been checked for suitability for the actual installation location and the Ex marking on the device must match the requirements.
- ▶ After installation and before initial commissioning, the complete equipment and the system must be inspected in compliance with IEC 60079-17.



#### **WARNING: Risk of explosion**

All electrical connections of the FLOWSIC500 are approved for connection to the certified intrinsically safe power circuits only.

- ▶ Proof of the intrinsic safety in compliance with IEC 60079-14 must be presented for interconnection with the associated intrinsically safe equipment.

Otherwise the intrinsic safety of the FLOWSIC500 can be endangered, i.e. the ignition protection for the FLOWSIC500 can no longer be ensured.

### Operating conditions for the ultrasonic sensors

The FLOWSIC500 is designed for use in potentially explosive atmospheres solely under normal atmospheric conditions within the following limits.

- Ambient pressure range 0.8 bar (11.6 psi) to 1.1 bar (15.95 psi)
- Air with normal oxygen content, normally 21 percent by volume

The ambient temperature must be within the range specified on the type plate.

The gas flow meter becomes part of the pipeline as soon as the FLOWSIC500 is installed in the pipeline.

The walls of the pipeline and the gas flow meter then serve as zone-separating barrier. The following Figure shows the different situations for a possible application and the operating conditions that apply.

Fig. 16

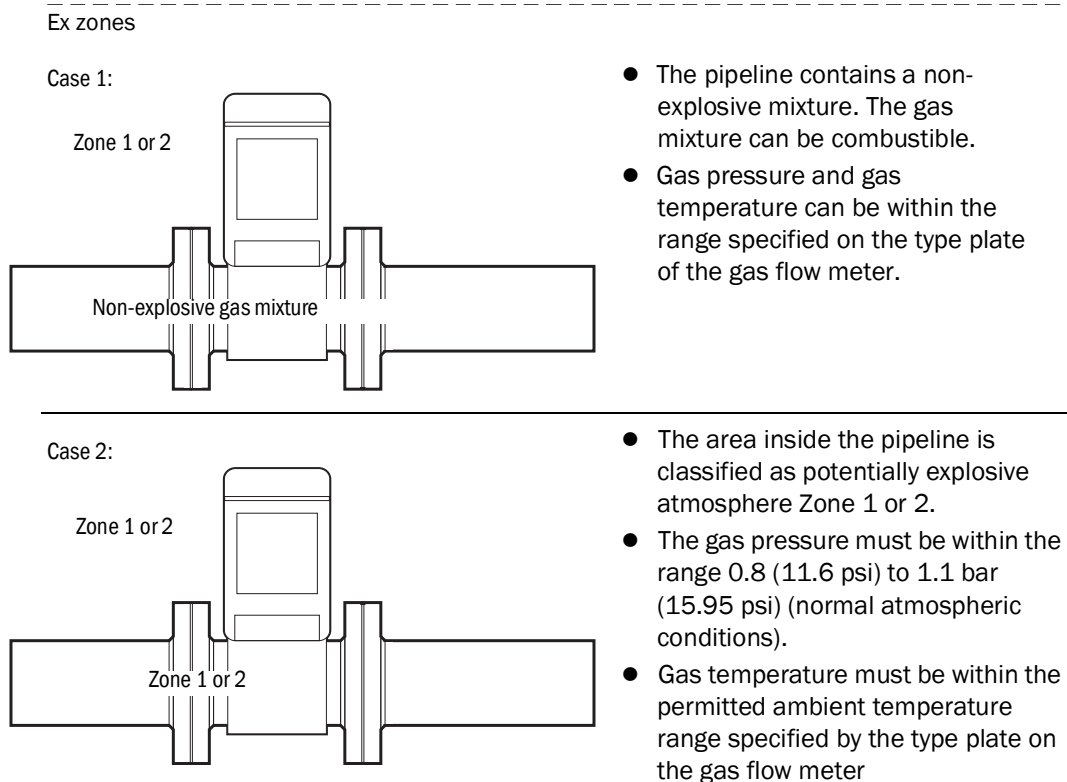

#### **WARNING: Risk of ignition through impacts or friction**

The ultrasonic transducers of the FLOWSIC500 are made of titanium. The pipe adapter and part of the electronic enclosure may be made of aluminum. In rare cases, ignition sources due to impact and friction sparks could occur. The maximum piezoelectric energy that can be released through impacts on the ultrasonic transducers exceeds the limit for Gas group IIC specified in §10.7 of EN60079-11:2012.

- ▶ For this reason, the ultrasonic transducers may only be used in zone 1 when risks of ignition arising from impacts or friction on the sensor housing can be ruled out within the application.
- ▶ Only ultrasonic transducers provided by SICK may be used!



### 3.4.2 Criteria for electrical connection

Installation work → p. 37, §3.3 must be completed.



**WARNING: Risk of explosion - hazard for intrinsic safety**

- ▶ The following work may only be carried out by skilled technicians familiar with the special characteristics of the intrinsic safety of the ignition protection type and who have knowledge of the relevant standards and regulations for interconnection of intrinsically safe power circuits.

### 3.4.3 Opening and closing the electronics cover



The Ex i terminal compartment of the FLOWSIC500 can be accessed after the electronics cover has been opened. The cover may also be opened in the hazardous area when under voltage. However, safe separation between the various intrinsically safe power circuits must not be breached.

**Opening the electronics cover**

- 1 Loosen the 4 screws (captive) on the electronics cover using an SW3 Allen key.

Fig. 17

Position of electronics cover screws

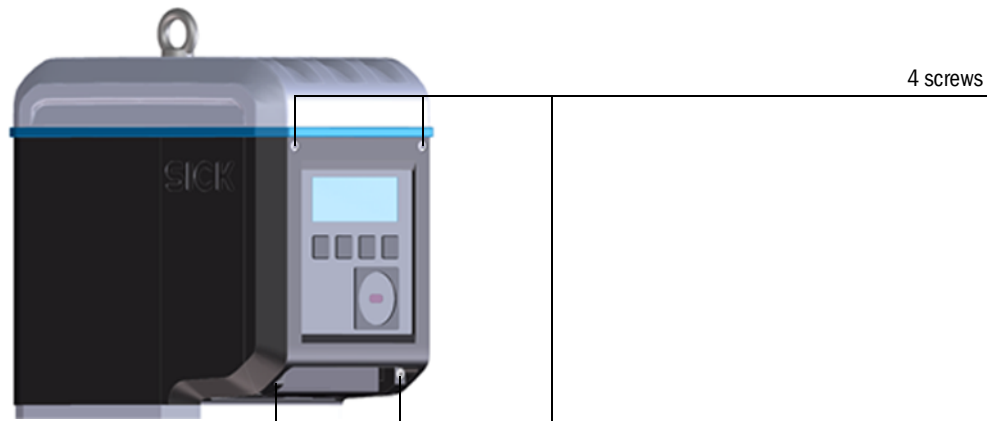

- 2 Open the electronics cover.

**Closing the electronic cover**

- 1 Close the electronics cover.



- ▶ Make sure no battery and display cables are pinched.

- 2 Screw the electronics cover tight again.  
Tightening torque: 2.0 Nm (18 lbf in)

### 3.4.4 Rotating the control unit

- 1 Open the electronics cover (→ p. 43, §3.4)
- 2 Loosen the 4 display screws with an SW3 Allen key, → Fig. 18.

Fig. 18

Position of display screws

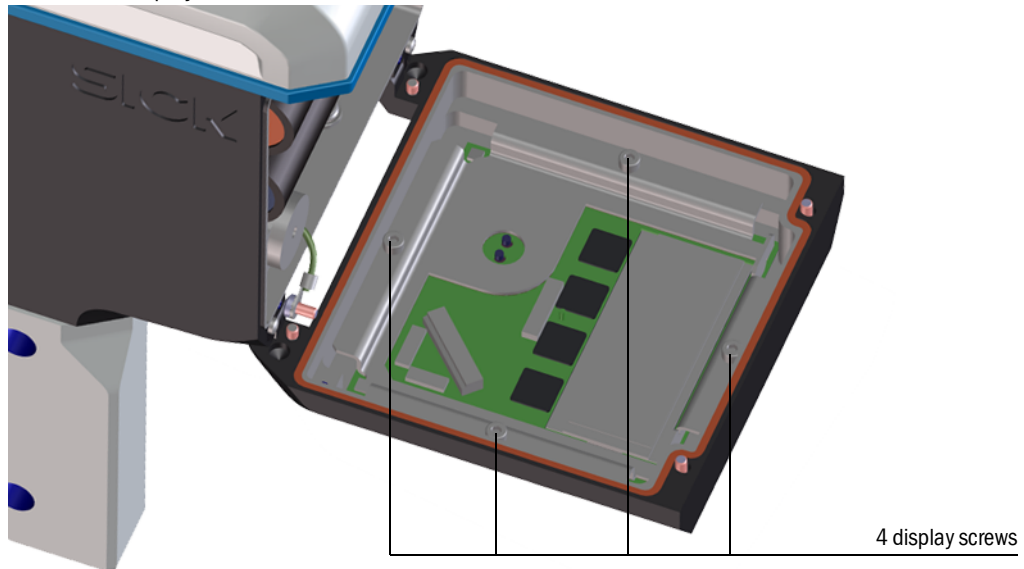

- 3 Check the display seal for intactness and correct fitting.
- 4 A new seal is available as spare part when the display seal is damaged (Part No. 2095177).
- 5 Rotate the display in the desired direction and reposition.
- 6 Tighten the display screws evenly.  
Tightening torque: 1.0 Nm (9 lbf in)
- 7 Close the electronics cover again.

### 3.4.5 Electrical connections

The FLOWSIC500 interfaces are accessible from the outside via external plug-in connectors.

Fig. 19 Connections

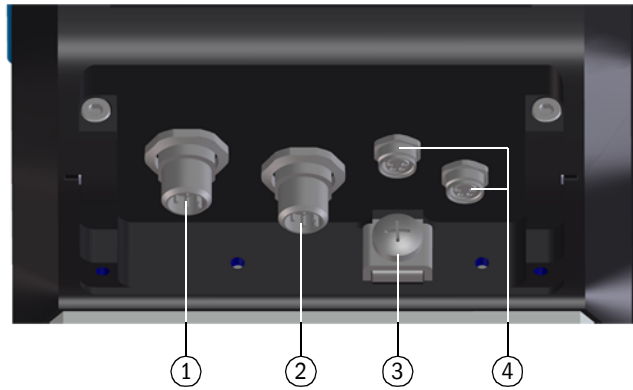

- 1 Plug-in connector 1 (B-coded): External power supply and signal output
- 2 Plug-in connector 2 (A-coded): Signal output
- 3 Ground screw
- 4 Connections for pressure/temperature sensors (optional)

Fig. 20 M12 plug-in connector coding

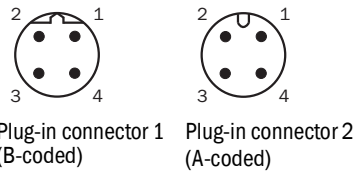

**NOTICE:**

Safety relevant parameters are valid for connecting all pins of a plug-in connector.



Plug-in connector 2 (A-coded) can be configured when ordered, configuration options → p. 48, §3.4.6.  
The respective configuration is printed on the type plate (→ p. 49).



The external power supply need not be connected when the FLOWSIC500 is operated with internal batteries.

### 3.4.6 Pin assignment of plug-in connectors

#### 3.4.6.1 Plug-in connector 1: External power supply and signal output

Table 12 Pin assignment for M12 plug-in connector 1 (male/B-coded, 4-poles)

| M12 pin | Input/output | Function/signal  | Operating parameters  | Safety relevant parameters  |
|---------|--------------|--|---|---|
| 1       | PWR-         | Voltage supply   | Rated input voltage 4.5 ... 16 V  | $U_i = 20\text{ V}$<br>$I_i = 667\text{ mA}$<br>$P_i = 753\text{ mW}$<br>$U_o = 8.2\text{ V}$<br>$I_o = 0.83\text{ mA}$<br>$P_o = 1.7\text{ mW}$<br>$C_o = 7.6\text{ }\mu\text{F}$<br>$L_o = 100\text{ mH}$ |
| 2       | PWR+         |  |   |   |
| 3       | DO_1-        | Diagnosis warning, Pulse output in test mode (→ Table 1) and for configuration K, $f_{\text{max}} = 2\text{ kHz at } 120\%$ $Q_{\text{max}}$ | OC (Open Collector)<br>Passive, not electrically isolated<br><br>Max. 16 V<br>Max. 100 mA<br>$R_{\text{on}} < 110\text{ }\Omega$<br>$R_{\text{off}} > 1\text{ M}\Omega$ |   |
| 4       | DO_1+        |  |   |   |

#### 3.4.6.2 Plug-in connector 2: Signal output

Table 13 Pin assignment for M12 plug-in connector 2 (male/A-coded, 4-poles)

| M12 pin  | Input/output | Function/signal   | Operating parameters   | Safety relevant parameters                   |
|--|--------------|---|--|--|
| <b>Pin assignment configuration 1: LF pulses and malfunction (electrically isolated), type code I/O: F</b> |              |   |  |  |
| 1  | DO_2+        | LF pulses<br>$f_{\text{max}}$ configurable to 100 Hz at 120% $Q_{\text{max}}$ | Passive, electrically isolated, configurable as:<br>OC (Open Collector)*:<br>Max. 16 V<br>Rated current 20 mA  | $U_i = 20\text{ V}$<br>$P_i = 753\text{ mW}$ |
| 2  | DO_2-        |   |  |  |
| 3  | DO_3-        | Malfunction   | or NAMUR:<br>Rated input voltage 8.2 V<br>$I_{\text{on}} = 3.4\text{ mA}$<br>$I_{\text{off}} = 0.7\text{ mA}$  |  |
| 4  | DO_3+        |   |  |  |
| <b>Pin assignment configuration 2: HF pulses and malfunction (electrically isolated), type code I/O: G</b> |              |   |  |  |
| 1  | DO_0+        | HF pulses<br>$f_{\text{max}}$ configurable to 2 kHz at 120% $Q_{\text{max}}$  | NAMUR, electrically isolated, optically isolated<br>Rated input voltage 8.2 V<br>$I_{\text{on}} = 3.4\text{ mA}$<br>$I_{\text{off}} = 0.7\text{ mA}$ | $U_i = 20\text{ V}$<br>$P_i = 753\text{ mW}$ |
| 2  | DO_0-        |   |  |  |
| 3  | DO_3-        | Malfunction   | Passive, electrically isolated, configurable as OC (Open Collector)* or NAMUR, see Configuration 1 for operating parameters                          |  |
| 4  | DO_3+        |   |  |  |
| <b>Pin assignment configuration 3: Encoder and LF pulses (electrically isolated), type code I/O: H</b>     |              |   |  |  |
| 1  | DO_0+        | Encoder log   | NAMUR, electrically isolated, optically isolated<br>Rated input voltage 8.2 V<br>$I_{\text{on}} = 3.4\text{ mA}$<br>$I_{\text{off}} = 0.7\text{ mA}$ | $U_i = 20\text{ V}$<br>$P_i = 753\text{ mW}$ |
| 2  | DO_0-        |   |  |  |
| 3  | DO_3-        | LF pulses   | Passive, electrically isolated, configurable as OC (Open Collector)* or NAMUR, see Configuration 1 for operating parameters                          |  |
| 4  | DO_3+        |   |  |  |

\* Standard configuration

Table 13 Pin assignment for M12 plug-in connector 2 (male/A-coded, 4-poles)

| M12 pin  | Input/output | Function/signal                                    | Operating parameters  | Safety relevant parameters   |
|--|--------------|--|---|--|
| <b>Pin assignment configuration 4: RS485 module (external feed), standard version: Type code I/O: J, low voltage version: Type code I/O: I</b> |              |  |   |  |
| 1  | PWR+         | RS485 module<br>(externally powered)               | Electrically isolated<br><br>Standard version:<br>Rated input voltage<br>$U_b = 4 \dots 16 \text{ V}$<br>Low voltage version:<br>Rated input voltage<br>$U_b = 2.7 \dots 5 \text{ V}$ | $U_i = 20 \text{ V}$<br>$P_i = 1.1 \text{ W}$<br>IIC: $C_i = 0.22 \mu\text{F}$<br>IIB: $C_i = 1.35 \mu\text{F}$<br>$L_i = 0.03 \text{ mH}$ |
| 2  | Data A       |  |   |  |
| 3  | PWR-         |  |   |  |
| 4  | Data B       |  |   |  |
| <b>Pin assignment configuration 5: Encoder and HF pulses (not electrically isolated), type code I/O: K</b>                                     |              |  |   |  |
| The HF pulses are output via plug-in connector 1 (DO_1), → Table 12.   |              |  |   |  |
| 1  | DO_0+        | Encoder log  | NAMUR, electrically isolated, optically isolated<br>Rated input voltage 8.2 V<br>$I_{on} = 3.4 \text{ mA}$<br>$I_{off} = 0.7 \text{ mA}$  | $U_i = 20 \text{ V}$<br>$P_i = 753 \text{ mW}$   |
| 2  | DO_0-        |  |   |  |
| 3  | DO_3-        | Malfunction  | Passive, electrically isolated, configurable as OC (Open Collector)* or NAMUR, see Configuration 1 for operating parameters   |  |
| 4  | DO_3+        |  |   |  |
| * Standard configuration   |              |  |   |  |
| <b>Pin assignment configuration 6: LF pulses and malfunction (electrically isolated), type code I/O: L</b>                                     |              |  |   |  |
| 1  | DO_2+        | LF pulses  | Passive, electrically isolated, configurable as:<br>OC (Open Collector)*:<br>Max. 16 V<br>Rated current 20 mA   | $U_i = 20 \text{ V}$<br>$P_i = 753 \text{ mW}$   |
| 2  | DO_2-        | $f_{max}$ configurable to 100 Hz at 120% $Q_{max}$ |   |  |
| 3  | DO_3-        | LF pulses  | or NAMUR:<br>Rated input voltage 8.2 V<br>$I_{on} = 3.4 \text{ mA}$<br>$I_{off} = 0.7 \text{ mA}$   |  |
| 4  | DO_3+        | $f_{max}$ configurable to 100 Hz at 120% $Q_{max}$ |   |  |

Fig. 21 Marking on the type plate (example)

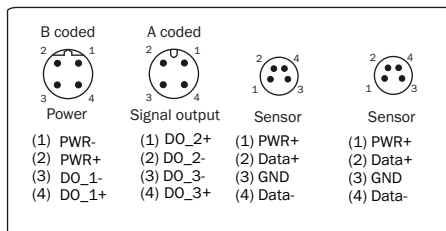

Internal terminal assignment → p. 142, §9.5

3.4.7 DO configuration switch (Open Collector - Namur)

Fig. 22 Open Collector - Namur

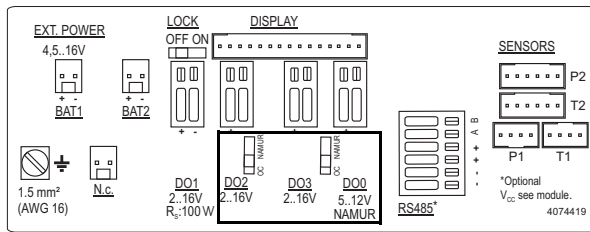
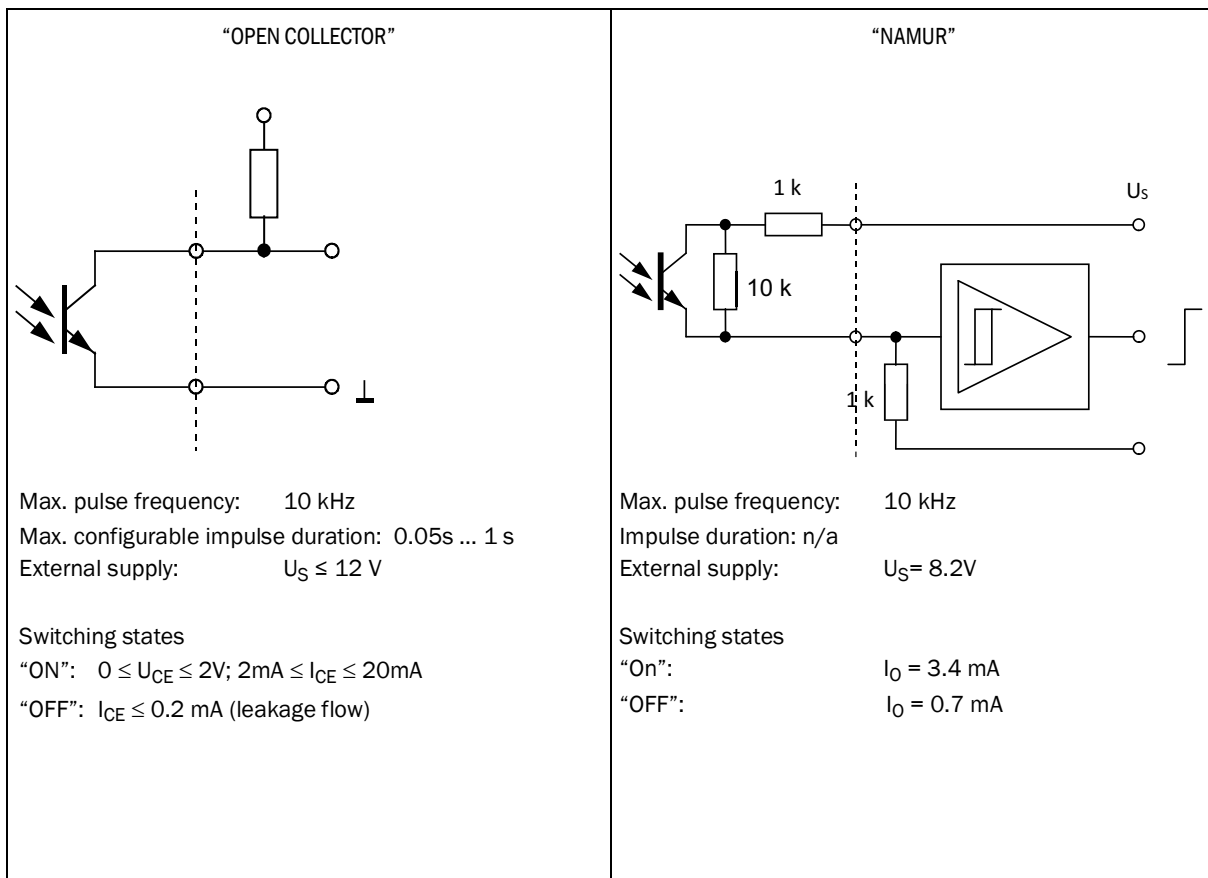



Figure 23 DO switching (Open Collector - Namur)



3.4.8

**Cable specifications**

When the plugs available from SICK are used, a shielded control cable with 4x0.25 mm<sup>2</sup> cross-section, with PVC insulation and approx. 5 mm outer diameter is required.

|   |   |
|---|---|
|  | <p><b>WARNING: Requirements on cables and installation</b></p> <ul style="list-style-type: none"> <li>▶ Pay attention to the requirements in EN 60079-14 when selecting the cables and during installation!</li> <li>▶ Further legal requirements must be observed for use in explosive atmospheres.</li> </ul> |
|---|---|

SICK recommends the ready-made cables available as accessories (→ p. 128, §8.1).

**Wire colors of the cable available as spare part**

Table 14

Power supply cable; for connection to plug-in connector 1, B-coded

| Part No.            | Pin | Wire color              | Plug  |
|---------------------|-----|-------------------------|---|
| 2067424,<br>2067425 | 1   | Brown                   |  |
|                     | 2   | White                   |   |
|                     | 3   | Blue                    |   |
|                     | 4   | Black (or yellow/green) |   |
| 2067632,<br>2067633 | 1   | White                   |   |
|                     | 2   | Brown                   |   |
|                     | 3   | Green                   |   |
|                     | 4   | Yellow                  |   |

Table 15

Data cable for connection to plug-in connector 2, A-coded

| Part No.            | Pin | Wire color              | Plug  |
|---------------------|-----|-------------------------|---|
| 2067422,<br>2067423 | 1   | Brown                   |  |
|                     | 2   | White                   |   |
|                     | 3   | Blue                    |   |
|                     | 4   | Black (or yellow/green) |   |
| 2067630,<br>2067631 | 1   | White                   |   |
|                     | 2   | Brown                   |   |
|                     | 3   | Green                   |   |
|                     | 4   | Yellow                  |   |

### 3.4.9 Operation with external power supply

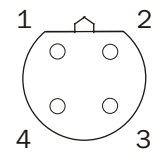

The FLOWSIC500 is designed electrically intrinsically safe.

- ▶ After correct installation has been checked, the plug connections in the hazardous area can be connected and disconnected under voltage as well.

#### 3.4.9.1 Connecting the external power supply

- 1 Connect the external intrinsically safe power supply to the M12 plug-in connector of the FLOWSIC500.  
Safety-relevant parameters → p. 48, §3.4.6.

Fig. 24

Connection for external power supply underneath the gas flow meter



1 External power supply and signal output

- 2 Switch the power supply on.  
The FLOWSIC500 is initialized.
- 3 Measurement starts and the current measured value for the gas volume appears.
- 4 Set the date and time (→ p. 64, §4.2).

#### 3.4.9.2 Connecting the backup battery

- 1 Open the electronics cover (→ p. 45, 3.4.3).
- 2 Connect the backup battery (Part No. 2065928) to connection BAT2 in the terminal compartment (→ Fig. 25).
- 3 Close the electronics cover again.

Fig. 25

Connected backup batteries

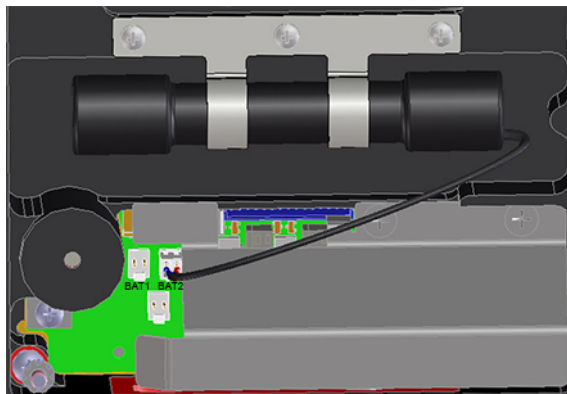



## 3.4.10

**Battery operation****WARNING: Ignition hazard through electrostatic charges**

Make sure the electrostatic risks when handling the transportable plastic battery packs are minimized.

- ▶ Take suitable precautionary measures, e.g. wear antistatic shoes, when a charge generating mechanism has been identified, e.g. repeated rubbing of battery packs against clothing.
- ▶ Putting the battery packs in the bag or carrying them on a belt, using a keyboard or cleaning with a damp cloth do not cause a significant electrostatic risk.



The FLOWSIC500 and the delivered battery packs are designed intrinsically safe.

- ▶ Only the exchangeable battery packs from SICK with Part No. 2064018 and the backup battery with Part No. 2065928 may be used.
- ▶ The battery packs can be connected and disconnected in the hazardous area as well.
- ▶ Only connect the battery packs to the connections marked for this purpose in the terminal compartment of the FLOWSIC500.
- ▶ Modifying the electrical connection parts is not allowed.

- 1 Open the electronics cover (→ p. 43, 3.4).
- 2 Insert the battery packs as shown and connect to connections BAT1 and BAT2 in the terminal compartment.  
The FLOWSIC500 is initialized.

Fig. 26

Connected battery packs

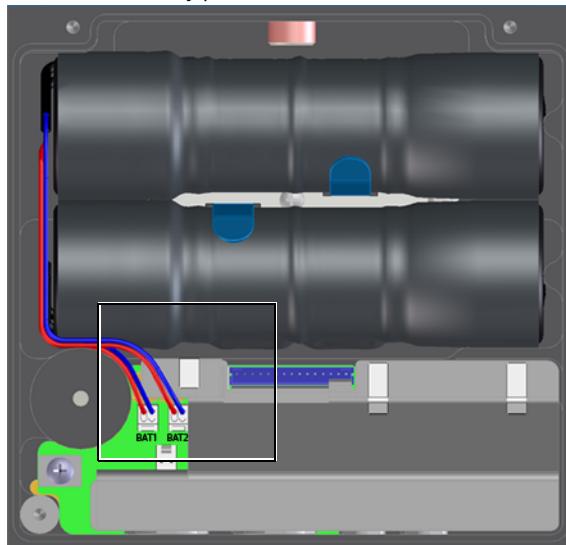

- 3 Close the electronics cover again.
- 4 Set the date and time (→ p. 64, §4.2).

## 3.5

**Installing the external pressure and temperature sensors**

The adapter of FLOWSIC500 has measuring ports for pressure and temperature.

**NOTICE:**

- ▶ The pressure measuring port to be used for measurement is marked "P<sub>M</sub>". On meters with flow direction "left-right" (→), the marked pressure measuring port is on the rear of the adapter, on meters with flow direction "right-left" (←), it is on the front.
- ▶ The pressure and temperature sensors can only be replaced when the parameter locking switch is open..

Fig. 27

Pressure and temperature measuring ports (front and rear side)

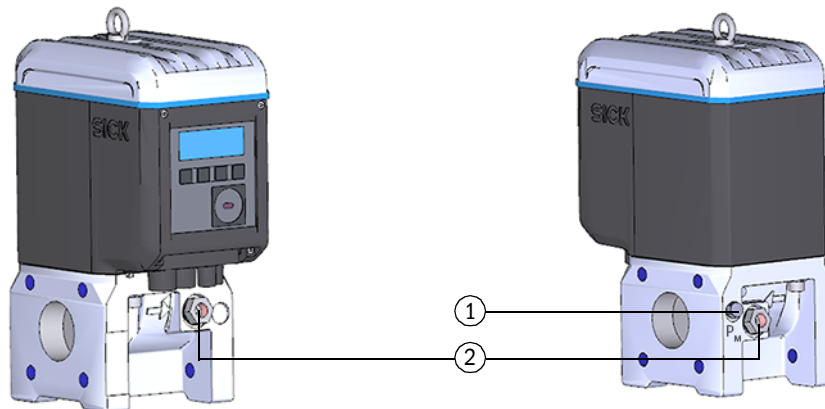

- 1 Pressure measuring port
- 2 Alternative temperature measuring ports

**NOTICE: Ensure sufficient assembly clearance!**

Ensure sufficient clearance to the wall or other components at the rear measuring ports when installing the sensors.

The recommended minimum clearance to the wall is 0.3 m.

## 3.5.1

**Fitting the plug-in connector cover**

Fit the plug-in connector cover before installing the sensors.

- 1 Guide the sensor plugs through the openings in the plug-in connector cover.

Fig. 28

Plug-in connector cover

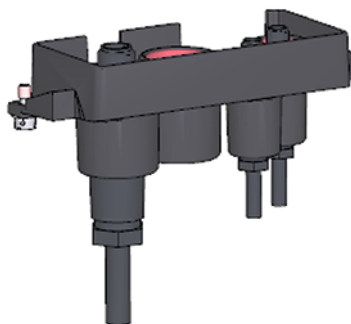

2 Connect the plugs to the planned connections.



For meter sizes DN50 and DN80, it is recommended to connect the pressure sensor to the right M8 connection and the temperature sensor to the left M8 connection.

The FLOWSIC500 automatically detects whether a pressure or temperature sensor has been connected to a connection.

Fig. 29

Connections for pressure and temperature sensors



1 Connections for pressure and temperature sensors

3 Push the plug-in connector cover over the plugs and fasten with both capstan screws.

Fig. 30

Fastening the plug-in connector cover

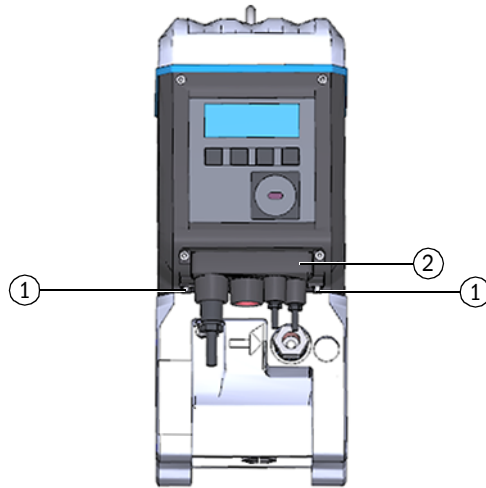

1 Capstan screw  
2 Plug-in connector cover

### 3.5.2 Installing the pressure sensor

A three-way test valve is normally fitted to be able to test the pressure sensor also when installed.



**NOTICE: Fitting information**

It is recommended to connect the pressure sensor with the three-way test valve or with the FLOWSIC500 so that there is a downward slope from the pressure sensor to the connection point and from the three-way test valve to the FLOWSIC500.

- ▶ Before installing a pressure sensor, check if there is a G 1/4" or NPT 1/4" thread on the meter body.
- ▶ The thread type is marked on the meter body:

Fig. 31

Marking on meter body

Thread G 1/4"

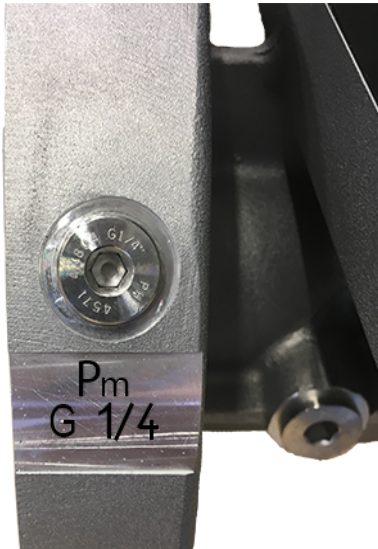

Thread 1/4" NPT



- ▶ When the meter body has an NPT 1/4" thread, screw in the adapter from NPT 1/4" to G 1/4" (Part No. 2075562) before using the accessory parts available from SICK.



**NOTICE:**

The thread on the meter body is damaged when a wrong thread type is screwed in.

Observe the marking on the meter body!

#### Variant 1: Installation with Kamstrup test valve BDA04 (up to -25 °C)



For details on installation with Kamstrup test valve BDA04, see Kamstrup Operating Instructions.

You will find the document on the delivered product CD.

- 1 Remove the dummy plug on the pressure measuring port marked "P<sub>m</sub>".
- 2 When the meter body has an NPT 1/4" thread, first screw in the adapter from NPT 1/4" to G 1/4" (Part No. 2075562).
- 3 Fit the Kamstrup test valve BDA04.  
Pay attention to the alignment of the connection for the pressure sensor.
- 4 Fit the pressure sensor on the Kamstrup test valve BDA04 (→ Fig. 32).

Fig. 32 Kamstrup test valve BDA04 with pressure sensor fitted

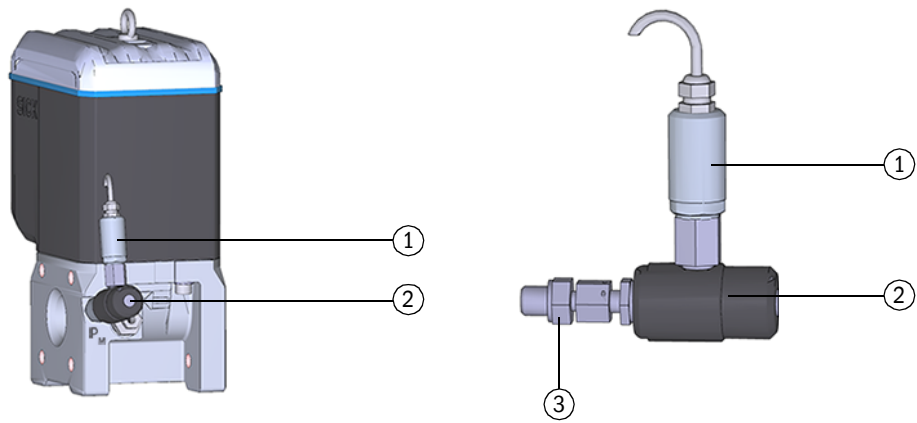

- 1 Pressure sensor, connection thread G 1/4"
- 2 Kamstrup test valve BDA04
- 3 FLOWSIC500 connection (G 1/4" male thread)

Table 16 Kamstrup test valve BDA04 positions

|                           |   |
|---------------------------|---|
| <p>Measuring position</p> | <p>Pressure sensor</p> <p>FLOWSIC500</p>                      |
| <p>Test position</p>      | <p>Test pressure</p> <p>Pressure sensor</p> <p>FLOWSIC500</p> |

Subject to change without notice

### Variant 2: Installation with three-way test valve (to -40 °C)

Here, a conventional three-way test valve is used.

Install the three-way test valve with pressure sensor fitted at a suitable location next to the FLOWSIC500. A pressure line serves to connect the pressure measuring connection of the FLOWSIC500 to the three-way test valve.

Two variants of the pressure connection set with three-way test valve are available. The type code indicates which variant must be selected.

- ▶ Check type code, position 6 "p-sensor connection", on the type plate (→ Fig. 2) of your FLOWSIC500.
- ▶ Select the connection set suitable for the pressure connection on the FLOWSIC500, → p. 128, §8.1.

| "Connection p-sensor" in type code | Pressure connection          |
|------------------------------------|------------------------------|
| 3                                  | Pipe screw fitting pipe 1/4" |
| 4                                  | Pipe screw fitting pipe D6   |

- ▶ For the complete type code description, see → p. 136, §9.2.

Fig. 33

Pressure connection on FLOWSIC500

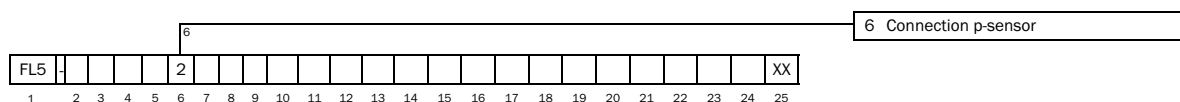

- 1 Fasten the three-way test valve at a suitable location.
- 1 Remove the dummy plug on the pressure measuring port marked "P<sub>m</sub>".
- 2 When the meter body has an NPT 1/4" thread, first screw in the adapter from NPT 1/4" to G 1/4" (Part No. 2075562).
- 3 Screw in the pipe screw fitting for pipe 1/4" or pipe D6.
- 4 Install the pressure line between the FLOWSIC500 and the three-way test valve.
- 5 Fit the pressure sensor to the three-way test valve.

Fig. 34

Pressure sensor installation on the three-way test valve (-40 °C)

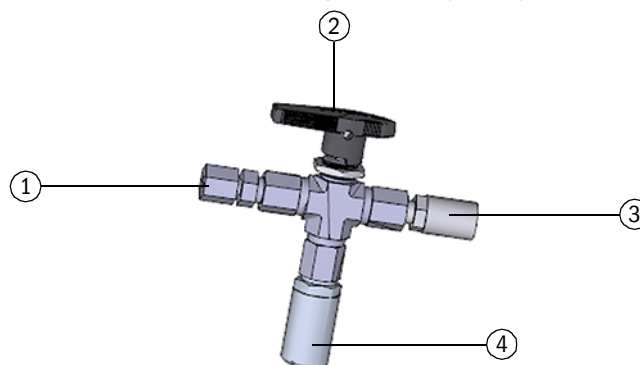

- 1 Pipe screw fitting 1/4" NPT on pipe D06  
or pipe screw fitting 1/4" NPT on pipe 1/4"
- 2 Hand lever
- 3 Test connection (Minimes coupling)
- 4 Pressure sensor, connection thread G 1/4"

Table 17 Three-way test valve positions

|                    |  |
|--------------------|--|
| Measuring position |  |
| Test position      |  |
| Closed position    |  |

**Variant 3: Installation without a three-way test valve**

Here, the pressure sensor is connected directly to the FLOWSIC500.

- 1 Remove the dummy plug on the pressure measuring port marked “P<sub>m</sub>”.
- 2 When the meter body has an NPT 1/4“ thread, first screw in the adapter (Part No. 2075562).
- 3 Fit the pressure sensor.

Fig. 35 Installation without three-way test valve

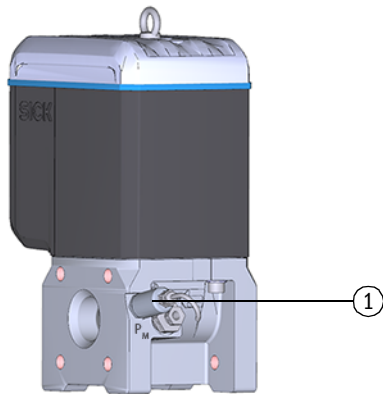

1 Pressure sensor, connection thread G 1/4“

Subject to change without notice

### 3.5.3 Installing the temperature sensor



**NOTICE:**

SICK recommends to install the temperature sensor on the temperature measuring port which is on the same side as the display.



The temperature sensor can be greased with heat-conductive oil or paste to improve its performance.

- 1 Insert the temperature sensor into the immersion sleeve to the stop.
- 2 Tighten the locknut.
- 3 Have the wire seal attached by a calibration inspector (→ Fig. 11).

Fig. 36

Installing the temperature sensor

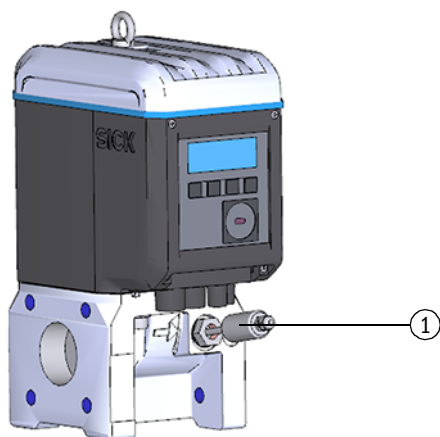

1 Temperature sensor

### 3.6

#### Fitting a display protector (option)

Display protector (Part No. 2085547) is available as an option for protection of the display from UV light.

Fig. 37

Display protection





**Tools required**

- Allen keys SW 3 and 2.5
- Jaw wrench SW 6



The Ex i terminal compartment of the FLOWSIC500 can be accessed after the electronics cover has been opened. The cover may also be opened in the hazardous area when under voltage. However, safe separation between the various intrinsically safe power circuits must not be breached.

- 1 Loosen and unscrew the two upper screws of the electronics cover with an Allen key SW 3.



- 2 Instead, mount the delivered screws with a SW 6 jaw wrench.



- 3 Mount the display cover with the pre-mounted screws (captive) using an Allen key SW 2.5.





# FLWSIC500

## 4 Commissioning

General information

Commissioning on the display

Commissioning with the FLOWgate™ operating software

## 4.1 General information

- All activities described in § 3 “Installation” must be completed before commissioning.
- Commissioning can be carried out directly on the device via the display, → p. 64, §4.2.
- The field setup wizard in the FLOWgate™ operating software supports an advanced commissioning, → p. 67, §4.3.



### **NOTICE: Measures in a metrologically secured area**

If stipulated by national regulations, measures on the device in the metrologically secured area after commissioning may be carried out only under official supervision.

- ▶ This must be coordinated with the authorities before carrying out the measures.
- ▶ All measures must be carried out based on this Manual.

## 4.2 Commissioning on the display

### 4.2.1 Commissioning sequence

#### 4.2.1.1 Gas flow meter commissioning

FLWSIC500 commissioning is normally performed in the following sequence:

- ▶ Log on as “Authorized user” (→ p. 90, §5.2.7).
- ▶ Set the date and time (→ p. 65, §4.2.2).
- ▶ Check the device status (→ p. 66, §4.2.4).

#### 4.2.1.2 Gas flow meter commissioning with device option volume conversion

- ▶ Log on as “Authorized user” (→ p. 90, §5.2.7).
- ▶ Set the date and time (→ p. 65, §4.2.2).
- ▶ Activate the configuration mode (→ p. 90, §5.2.9).
- ▶ Set fixed values for pressure and temperature (→ p. 65, §4.2.3.1).
- ▶ Set reference values (already configured: → Table 4).
- ▶ Select the calculation method (already configured: → p. 87, §5.2.6.5)
- ▶ Set the fixed value of the compressibility factor (→ p. 87, §5.2.6.5).
- ▶ Check the configuration (→ p. 66, §4.2.3.3).
- ▶ Configure the gas composition (→ p. 66, §4.2.3.3).
- ▶ Adapt alarm limits for pressure and temperature (→ p. 88, §5.2.6.6 and → p. 88, §5.2.6.7).



The alarm limits are set in the factory to the measuring range of the selected sensor

- ▶ Terminate configuration mode (→ p. 90, §5.2.9).
- ▶ Check the device status (→ p. 66, §4.2.4).

## 4.2.2 Setting the date and time

Date and time must be set after the power supply has been connected. The FLOWSIC500 displays error E-3007 (“Time invalid”) until the time has been set.



Detailed information on operating using the display and on menu navigation  
→ p. 76, §5.2.



- The time zone function adapts the time to the new time zone.  
If you want to change date and time as well as the time zone, change the time zone first.
- Date and time can be changed without starting configuration mode.

- 1 Log on as “Authorized user” (→ p. 90, §5.2.7).
- 2 Switch to the “System settings” submenu in the FLOWSIC500 menu.
- 3 Call up “Date”.
- 4 Press ENTER to start the edit mode.  
The cursor now blinks under the first position of the date.
- 5 Use the arrow buttons to increment or decrement the selected position by 1 until the correct digit is shown.
- 6 Confirm with ENTER.  
The cursor now blinks under the second position of the date.
- 7 Repeat for the remaining positions of the date.  
The date is saved when you confirm the last position with ENTER.
- 8 Switch to “Time”.
- 9 Use the arrow buttons to increment or decrement the first position of the time by 1 until the correct digit is shown.
- 10 Confirm with ENTER.
- 11 Repeat for the remaining positions of the time.  
The time is saved when you confirm the last position with ENTER.

## 4.2.3 Configuring volume conversion (device option)

### 4.2.3.1 Setting fixed values

The fixed values must be set to the average measurement conditions of pressure and temperature:

- 1 Log on as “Authorized user” (→ p. 90, §5.2.7).
- 2 Start the configuration mode (→ p. 90).
- 3 In the FLOWSIC500 menu, switch to submenu “Pressure parameters” or “Temperature parameters”
- 4 Select the view “p Fixed value” or “T Fixed value”.
- 5 Press ENTER to start the edit mode.  
The cursor now blinks under the first position of the parameter.
- 6 Use the arrow buttons to increment or decrement the selected position by 1 until the correct digit is shown.
- 7 Confirm with ENTER.  
The cursor now blinks under the second position of the parameter.
- 8 Repeat for all remaining positions of the parameter.  
The fixed value is saved when you confirm the last position with ENTER.

#### 4.2.3.2 Checking the configuration

The FLOWSIC500 is delivered already configured according to customer specifications. It is recommended to check the custody-relevant parameters and settings. The custody relevant parameters are shown in the delivered Parameter report and can be compared against the current configuration on the display.

A new Parameter report can be created using the FLOWgate™ operating software:

- ▶ Open the menu “Parameter change” in the FLOWgate™ operating software.
- ▶ Click “Create Parameter report”. The report is generated.
- ▶ File the report with the device documentation.

#### 4.2.3.3 Configuring the gas composition

- 1 Log on as “Authorized user” (→ p. 90, § 5.2.7).
- 2 Start the configuration mode (→ p. 90).
- 3 Switch to submenu “Conversion/Gas composition” in the FLOWSIC500 menu.
- 4 Set the parameters to characterize the gas to be measured according to the selected K-number calculation method.



**NOTICE:**

Configuration of gas composition may only be changed once a day. More frequent changes may damage the internal parameter memory (EEPROM) and thus shorten the service life of the FLOWSIC500.



Parameter changes of the gas composition are stored in the Gas composition logbook.

The Gas composition logbook can be viewed using the FLOWgate™ operating software (menu “Logbook management” > “Gas composition logbook”).

#### 4.2.4 Checking the device status

Make sure the FLOWSIC500 is in error-free operating status:

- 1 Log on as “Authorized user” (→ p. 90, § 5.2.7).
- 2 Check whether warnings or errors are shown in the symbol bar on the display.

|  |  |
|--|--|
|  | The device has a warning.<br>The FLOWSIC500 is in “Warning” status.    |
|  | The device has an error.<br>The FLOWSIC500 is in “Malfunction” status. |

- 3 If warnings or malfunctions exist, change to view “Current events” on the main display:
  - Clear existing malfunctions (→ p. 94, § 6.2, “Status messages”).
  - Contact SICK Customer Service for any malfunctions you cannot clear yourself (→ p. 94, § 6.1, “Contacting Customer Service”).
- 4 The event overview can be reset when all warnings and errors have been cleared (→ p. 91, § 5.2.12).

## 4.3 Commissioning with the FLOWgate™ operating software

### 4.3.1 Connect to the device

A data connection can be established with the device using the optical data interface and the infrared/USB adapter HIE-04 (Part No. 6050502).

This interface serves to configure the FLOWSIC500. The infrared/USB adapter has a USB 2.0 interface. This interface provides the connection to the PC and transfers the FLOWSIC500 data.



A device driver software must first be installed to operate the adapter on a PC. The device driver software is on the delivered Product CD.

- 1 Install the device driver software before connecting the USB plug to the PC.
- 2 Connect the USB plug to the PC.
- 3 Fit the infrared/USB adapter to the infrared interface as shown (→ Fig. 38), a magnet integrated in the reading head retains the adapter.

Fig. 38

Alignment of the infrared adapter

Correct alignment



Wrong alignment



- 4 Install the FLOWgate™ operating software. The FLOWgate™ operating software and the associated Manual can be found on the Product CD delivered with the FLOWSIC500 and are also available under [www.sick.com](http://www.sick.com).
- 5 Press any button on the display to activate the optical data interface on the FLOWSIC500. When a connection has been established with the infrared/USB adapter, the optical data interface on the FLOWSIC500 remains active until the infrared/USB adapter is removed.
- 6 The display and the optical interface remain active during the connection.
- 7 Click on the FLOWgate™ icon to start FLOWgate™:

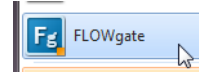

- 8 Add the FLOWSIC500 to the Device Manager of the FLOWgate™ operating software and create a connection to the device.
- 9 Login as “Authorized User” on the device.



Standard password for “Authorized User”: 2222

- 10 Start the field setup wizard and follow the step-by-step instructions.

### 4.3.2 Field setup wizard



**NOTICE:**

Configuration mode must be active to change parameters.

- ▶ Click on the symbol in the toolbar to activate configuration mode.

#### 4.3.2.1 Device identification

- ▶ Check the device serial number and type code: Compare the entries against the type plate.
- ▶ Enter a device name: The device name is freely selectable.

#### 4.3.2.2 System/User

##### Date and time

- ▶ Enter the date and time or synchronize with the PC.

After completing commissioning, the daylight saving time settings can be activated and configured, see → p. 72, §4.3.3.

##### User management



**NOTICE:**

SICK recommends changing the initial password provided for the “Authorized User” for security reasons.

Further users can be activated here when desired.

- ▶ Activate the associated checkbox of the desired user.
- ▶ Specify a password. The password must comprise 4 digits.

Up to three users and three authorized users can be activated. “Authorized User 1” and “User 1” are always activated,

For access rights for single user levels, see → p. 20, §2.3.3.

Fig. 39

Example

| USER MANAGEMENT   |                                     |          |
|-------------------|-------------------------------------|----------|
| User              | Activate                            | Password |
| User 1            |                                     | ••••     |
| User 2            | <input checked="" type="checkbox"/> | ••••     |
| User 3            | <input checked="" type="checkbox"/> | ••••     |
| Authorized User 1 |                                     | ••••     |
| Authorized User 2 | <input checked="" type="checkbox"/> | ••••     |
| Authorized User 3 | <input type="checkbox"/>            | ••••     |

#### 4.3.2.3 Warnings

The “Warnings” area serves to set the limit values outside of which the FLOWSIC500 is to output warnings (flow rate) or errors (pressure and temperature).

Limit values can be set for:

- Flow rate
- Pressure
- Temperature
- Reverse flow volume (buffer volume)
- Limit value for low flow rate (zero-flow cutoff)



## 4.3.2.4

**Communication**

- ▶ The configuration of the single plug-in connectors is preset according to the configuration ordered. Check the configuration and adapt when necessary.
- ▶ For pulse outputs, the maximum frequency and the minimum pulse width must be set during commissioning.
- ▶ The status outputs are configured as standard so that status “Measurement invalid” is output. Selecting status “Measurement valid” shortens the battery service life considerably because the output is then permanently activated.

**Plug 1: B-coded**

- ▶ Configuration as status or pulse output possible: Select the desired configuration.
- ▶ Enter the maximum frequency and minimum pulse width in the “Pulse 1” area when configuring as a pulse output.

When configured as a pulse output, make sure the overload frequency of 120%  $Q_{\max}$  is covered and the connected device understands the frequency.

The following conditions must be satisfied:

- The “Maximum frequency” must be set to a value higher or equal to the “Frequency at  $Q_r$ ”.
- The “Minimum pulse width” must be set to a value lower or equal to  $1/(2 \times \text{“Frequency at } Q_r\text{”})$ .

**Example**

Frequency at  $Q_r$  = 382 Hz

Maximum frequency:

Set “Maximum frequency” to a value  $\geq 382$  Hz.

Recommendation. Round up to 400 Hz.

Minimum pulse width:

1 Hz corresponds to 1000 ms

382 Hz corresponds to 2.6 ms

$1/(2 \times \text{“Frequency at } Q_r\text{”}) = 1.3$  ms

Set “Minimum pulse width” to an integer value  $< 1.3$  ms.

Recommendation: set 1 ms.

Fig. 40

Pulse settings example

| PULSE 1 SETTINGS    |            |
|---------------------|------------|
| Corrected volume    | [Dropdown] |
| Pulse Output Value  | [Dropdown] |
| Hz                  | 400        |
| Maximum Frequency   |            |
| Hz                  | 382        |
| Frequency at $Q_r$  |            |
| Imp/m <sup>3</sup>  | 7162.509   |
| Meter Factor        |            |
| ms                  | 1          |
| Minimum Pulse Width |            |

**Plug 2: A-coded**

- ▶ Configuration as status or pulse output possible: Select the desired configuration.
- ▶ Enter the maximum frequency and minimum pulse width in the “Pulse 2” area when configuring as a pulse output.  
For configuration, see Section “Plug 1: B-coded”.

**Communication tests**

- Pulse output:
  - Enter the desired test frequency.
  - Push the slider to “On” to start the test. The test frequency is output on all pulse outputs.

Fig. 41

## Pulse output test

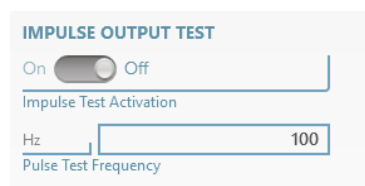

- Flow rate
  - Enter the desired test flow rate and start the test.
- Digital output
  - Select the desired digital output.
  - Push the slider to “On”.

## 4.3.2.5

**Volume conversion (only for device option volume conversion)**

For a detailed description of the single parameters, see the FLOWSIC500 menu description, p. 87, §5.2.6.5.

- ▶ Determine the reference values.
- ▶ Enter the specifications for gas characteristics.
- ▶ Select the algorithm and parameters for calculating the compressibility factor.
- ▶ Enter fixed values.

#### 4.3.2.6 Totalizers

##### Totalizers

- ▶ Setting or resetting the totalizer levels.
- ▶ Determine the limits for the reverse flow volume.

##### Meter settings

- ▶ Configure the significant digits for the meters:  
All meters have up to 9 significant digits, without sign. The number of significant digits can be varied between 5 to 9.
- ▶ Determine the resolution for the meters:  
The totalizer resolution can be set in the range 0.001 to 100 in increments of factor 10 for the volume at flowing conditions and the volume at base conditions of the meter. It is therefore necessary to multiply the totalizer level with the corresponding totalizer resolution to interpret the totalizer level.

**NOTICE:**

The totalizer levels are stored in the unit system set in the device. The unit and resolution are stored in the data records so that the logbooks remain constant when these settings are changed and need not be reset.

All totalizer levels are deleted when the unit or totalizer resolution are changed.

#### 4.3.2.7 Completion

- ▶ If desired, empty the logbooks and archive:
  - Activate the checkbox of the logbooks or archive to be emptied.
  - Click "Clear selected".
- ▶ Check the collection status. If desired, reset the Event overview.
- ▶ Create a Parameter report:
  - Click "Create Parameter report". The report is generated.
  - File the report with the device documentation.

### 4.3.3 Activate and configure the daylight saving time

- 1 Open the tile “System/User” in the “Parameter Modification” area.
- 2 Activate Configuration mode.
- 3 Activate the daylight saving time.

Fig. 42 Activating the daylight saving time settings

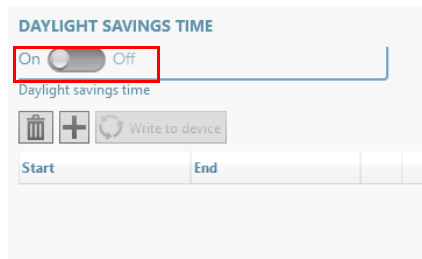

- 4 Click “+” to enter a new time period for daylight saving time.
- 5 Use the arrow buttons to set the start of the daylight saving time.  
The FLOWgate™ operating software always increases or reduces the position you clicked beforehand; e.g. the month is increased when the month is clicked. The year is increased when the year is clicked. The FLOWgate™ operating software increases the day by 1 when the text box is not clicked.  
The date can also be entered using the keyboard.

Fig. 43 Setting the time period for the daylight saving time

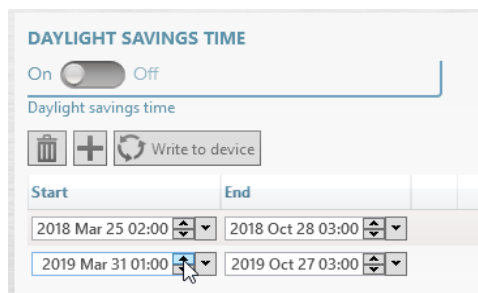

- 6 Then set the end of the daylight saving time.
- 7 Click “Write to device” to write the daylight saving time to the FLOWSIC500.
- 8 Enter further time periods when desired. Daylight saving time start and end can be configured for up to 10 years in advance.

#### 4.3.4 Configure the power management

Select the type of power supply corresponding to the configuration of the FLOWSIC500:

- Dynamic Mode (External + Backup):  
Measuring rate: 4 Hz
- Battery Mode (2 x Battery):  
Measuring rate: 1 Hz, to maximize the battery service life
- Eco Mode (External + Backup):  
Standard setting: Measuring rate is 4 Hz when the external voltage supply is available.  
The measuring rate is set automatically to 1 Hz if the external voltage supply fails in order to maximize the backup battery service life.

Fig. 44



Power management

The screenshot displays the 'POWER MANAGEMENT' configuration screen. At the top, a dropdown menu is set to 'Battery-Mode (2 x Battery)'. Below this, the 'Power mode' is indicated. To the right, the 'Response time' is set to '30s'. Further down, the 'Filter size' is set to '20' and the 'Measure rate' is set to '8' Hz. On the left side, there are two battery level indicators: 'Battery 2 level' is set to '100%' and 'Battery 1 level' is set to '0%'. Each level indicator includes a 'Change battery' button with a lightning bolt icon.

4.3.5 **Function check after commissioning**

- ▶ Check the device status.

Table 18 Signaling the device status in FLOWgate™

| Status  | Description  |
|---|--|
|  | Normal operation, neither warnings nor errors exist  |
|  | Device status warning: At least one warning is pending in the device, the measured value is still valid. |
|  | Device status error: At least one error is pending in the device, the measured value is invalid.         |

- ▶ Click on the symbol in the Status bar when warnings or errors exist.  
The current Status overview opens and shows details and information on how to proceed.

# FLWSIC500

## 5 Operation

Control unit  
Operating using the display

## 5.1 Control unit

Fig. 45 Operating and display elements

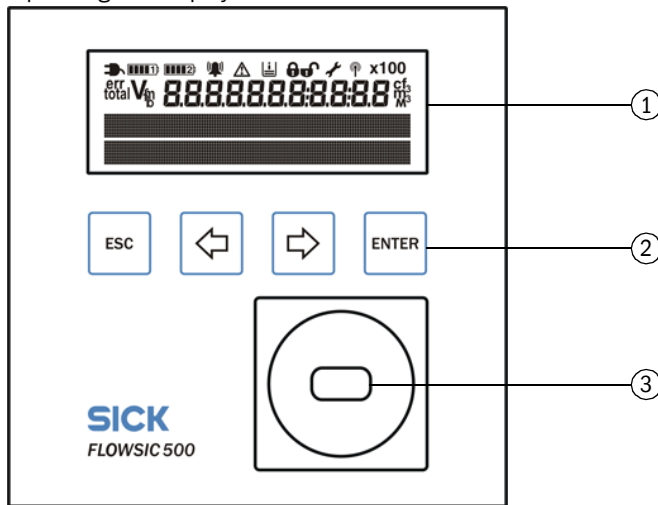

- 1 Display
- 2 Buttons
- 3 Optical data interface

## 5.2 Operating using the display

- ▶ Press any button to switch the display on.



In battery operation, the display and the optical data interface have a timeout and switch off after approx. 60 seconds (default setting) when not button has been pressed and no data transmission takes place.

The display and the optical interface are permanently active when an external power supply is connected.

Table 19 Buttons

|       | In menu   | In Edit mode  |
|-------|---|---|
| Esc   | Returns to next higher level of the operator menu | Aborts input of new value and returns to the next higher level of the operator menu.  |
| ←     | Toggles between single menu entries on one level  | Increments or decrements a parameter by 1, toggles between several selection options. |
| →     |   |   |
| ENTER | Calls a submenu, starts edit mode.                | Confirms an input.  |











5.2.1

**Display in the symbol bar**

Table 20

Symbols

| Symbol   | Significance                    | Description  |
|--|---------------------------------|--|
|   | External power supply           | Only displayed when the device is configured with external power supply.   |
|   | Battery fill level, battery 1   | Displayed when the FLOWSIC500 is configured for battery operation: Status of the first battery pack<br>Details on the battery fill level → p. 77, § 5.2.2.       |
|   | Battery fill level, battery 2   | With external power supply: Backup battery status.<br>With battery operation: Second battery pack status.<br>Details on the battery fill level → p. 77, § 5.2.2. |
|   | Device status: Malfunction      | The device has an error, the measured value is invalid.  |
|   | Device status: Warning          | The device has a warning, the measured value is still valid.   |
|   | Registered events               | Events have occurred since the last event summary reset.   |
|   | Parameter locking switch closed | Metrologically relevant parameters are protected against changing; modifications are registered in the Metrology logbook → p. 28, § 2.8.2.                       |
|   | Parameter locking switch open   | Metrologically relevant parameters can be changed; the modifications are not saved in the Metrology logbook.   |
|  | Configuration mode              | Device parameters can be changed.  |



**NOTICE:**

In device status “Malfunction” or “Warning”, the respective symbols are shown blinking on the display.





5.2.2

**Battery fill level display**

The battery symbol changes as the battery is discharged.

Table 21

Battery fill level display

|   |                                       |
|---|---------------------------------------|
|  | Battery fill level > 75%              |
|  | Battery fill level > 50%              |
|  | Battery fill level > 25%              |
|  | Battery fill level > 25%              |
|  | Battery almost empty but still in use |

- The last segment of the battery symbol starts to blink when the battery fill level drops below 10%.
- When the battery is completely empty, the empty battery symbol blinks and the FLOWSIC500 has switched to the second battery.

5.2.3

**Main screen (without device option volume conversion)**

- ▶ Use buttons  $\leftarrow$  and  $\rightarrow$  to toggle between the menu entries on a level.
- ▶ Press ENTER to go down one menu level.

**Main display**

The following information is displayed on the top display menu level:

| Main display   | Description   |
|--|---|
| <div style="border: 1px solid black; padding: 5px;"> <p>V                    000000000 m<sup>3</sup><br/>                     20.08.2012            10:30:52</p> </div>  | <p>V = Volume absolute, cannot be reset</p>   |
| <p>↳ Pressing ENTER opens the FLOWSIC500 menu.</p>   |   |
| <div style="border: 1px solid black; padding: 5px;"> <p>errV                    000000000 m<sup>3</sup><br/>                     20.08.2012            10:30:52</p> </div>   | <p>errV = Error volume: Volume counted during a malfunction, can be reset</p>                                   |
| <p>↳ Pressing ENTER opens the action "Reset error volume".<br/>                     → "Resetting the error volume" (p. 91).</p>  |   |
| <div style="border: 1px solid black; padding: 5px;"> <p>Q                            0.000 m<sup>3</sup>/h<br/>                     VOG                    0.000 m/s</p> </div>  | <p>Q = Volume flow<br/>                     VOG = Gas velocity</p>  |
| <div style="border: 1px solid black; padding: 5px;"> <p>Current events<br/>                     1 Event</p> </div>   | <p>Current events (1 event is reported)</p>   |
| <p>↳ Pressing ENTER opens a list of current reported events.<br/>                     Use the arrow buttons to toggle through the reported events.</p>   |   |
| <div style="border: 1px solid black; padding: 5px;"> <p>Event Summary<br/>                     2 Events</p> </div>   | <p>Stored status messages: Events since the last time the event summary was reset (2 events have occurred).</p> |
| <p>↳ Pressing ENTER opens a list of stored events.<br/>                     Use the arrow buttons to toggle through the stored events.</p>   |   |
| <div style="border: 1px solid black; padding: 5px;"> <p>Last Event Reset<br/>                     20.08.2012            10:30:52</p> </div>  | <p>Last reset of event summary</p>  |
| <p>↳ Pressing ENTER opens the action "Reset Event Summary".<br/>                     → "Resetting the event summary" (p. 91).</p>  |   |
| <div style="border: 1px solid black; padding: 5px;"> <div style="display: flex; align-items: center;"> <p><b>NOTICE:</b><br/>                     A parameter with Malfunction status is shown on the display by a blinking exclamation mark after the parameter (e. g. Q!).</p> </div> </div> |   |

**Menu navigation (without device option volume conversion)**

Some menu functions are only available when you are logged in with user level “User” or “Authorized User”:

|                |                    |                                    |  |
|----------------|--------------------|------------------------------------|--|
| User level:    | G Guest (standard) | U User (1)<br>User (2)<br>User (3) | A1 Authorized user (1)<br>A2 Authorized user (2)<br>A3 Authorized user (3) |
| Access rights: | - Hidden           | ○ View                             | ● Start/edit   |

| Path  | G | U | A2+3 | A1 | Explanation       |
|---|---|---|------|----|-------------------|
| <b>Main display: Volume under measurement conditions V</b>                  | ○ | ○ | ○    | ○  |                   |
| <b>FLWSIC500 menu: User</b>   | ○ | ○ | ○    | ○  |                   |
| Logged in user level  | ● | ● | ●    | ●  | → p. 85, §5.2.6.1 |
| Login   | ● | ● | ●    | ●  |                   |
| Logout  | - | ● | ●    | ●  |                   |
| <b>FLWSIC500 menu: Device mode</b>  | ○ | ○ | ○    | ○  | → p. 85, §5.2.6.2 |
| Calibration mode  | ○ | ○ | ●    | ●  |                   |
| Configuration mode  | ○ | ○ | ●    | ●  |                   |
| <b>FLWSIC500 menu: Device information</b>                                   | ○ | ○ | ○    | ○  | → p. 85, §5.2.6.3 |
| Measuring port  | ○ | ○ | ○    | ○  |                   |
| Serial number   | ○ | ○ | ○    | ○  |                   |
| Firmware Version  | ○ | ○ | ○    | ○  |                   |
| Firmware Date   | ○ | ○ | ○    | ○  |                   |
| Firmware CRC  | ○ | ○ | ○    | ○  |                   |
| Metrology CRC   | ○ | ○ | ○    | ○  |                   |
| Min. oper. pressure   | ○ | ○ | ○    | ○  |                   |
| Max. oper. pressure   | ○ | ○ | ○    | ○  |                   |
| Meter factor  | ○ | ○ | ○    | ○  |                   |
| Frequency at Qr [Hz]  | ○ | ○ | ○    | ○  |                   |
| Meter factor 2  | ○ | ○ | ○    | ○  |                   |
| <b>FLWSIC500 menu: System settings</b>                                      | ○ | ○ | ○    | ○  | → p. 86, §5.2.6.4 |
| Power supply (1) [%]  | ○ | ○ | ●    | ●  |                   |
| Power supply (2) [%]  | ○ | ○ | ●    | ●  |                   |
| Date  | ○ | ○ | ●    | ●  |                   |
| Time  | ○ | ○ | ●    | ●  |                   |
| Timezone  | ○ | ○ | ●    | ●  |                   |
| Language  | ○ | ● | ●    | ●  |                   |
| Symbols   | ○ | ○ | ○    | ○  |                   |
| LCD test  | ○ | ● | ●    | ●  |                   |
| <b>FLWSIC500 menu: Logbooks</b>   | ○ | ○ | ○    | ○  |                   |
| Event logbook   | ○ | ○ | ○    | ○  |                   |
| List of stored events   | - | ○ | ○    | ○  |                   |
| Parameter logbook   | ○ | ○ | ○    | ○  |                   |
| Metrology logbook   | ○ | ○ | ○    | ○  |                   |
| <b>FLWSIC500 menu: Archives</b>   | ○ | ○ | ○    | ○  | → p. 89, §5.2.6.9 |
| Gas hour  | ○ | ○ | ●    | ●  |                   |
| Gas day   | ○ | ○ | ●    | ●  |                   |
| Measuring period  | ○ | ○ | ●    | ●  |                   |
| <b>Main display: Error volumes errV</b>                                     | ○ | ○ | ●    | ●  |                   |
| <b>Main display: Volume flow under measurement conditions/ gas velocity</b> | ○ | ○ | ○    | ○  |                   |
| <b>Main display: Current Events</b>   | ○ | ○ | ○    | ○  |                   |
| List of current events  | ○ | ○ | ○    | ○  |                   |
| <b>Main display: Event Summary</b>  | ○ | ○ | ○    | ○  |                   |
| List of stored events   | ○ | ○ | ○    | ○  |                   |
| <b>Main display: Last Event Reset</b>                                       | ○ | ○ | ●    | ●  | → p. 91, §5.2.12  |

Subject to change without notice

5.2.4

**Main display (with device option volume conversion)**

► Use buttons  $\leftarrow$  and  $\rightarrow$  to toggle between the menu entries on a level.  
Press ENTER to go down one menu level.



The symbols on the display are shown as standard in accordance with EN12405.  
Symbols with regional deviations can be configured.  
These Operating Instructions use symbols in accordance with EN12405.

**Main display (with device option volume conversion)**

The following information is displayed on the top display menu level:

| Main display  | Description              |                          |            |                         |   |
|---|--------------------------|--------------------------|------------|-------------------------|---|
| <table border="1"> <tr> <td><math>V_b</math></td> <td>000000000 m<sup>3</sup></td> </tr> <tr> <td>20.08.2012</td> <td>10:30:52</td> </tr> </table>                | $V_b$                    | 000000000 m <sup>3</sup> | 20.08.2012 | 10:30:52                | $V_b$ = Volume at base conditions, uninterrupted  |
| $V_b$   | 000000000 m <sup>3</sup> |                          |            |                         |   |
| 20.08.2012  | 10:30:52                 |                          |            |                         |   |
| ↳ Pressing ENTER opens the FLOWSIC500 menu.   |                          |                          |            |                         |   |
| <table border="1"> <tr> <td><math>errV_b</math></td> <td>000000000 m<sup>3</sup></td> </tr> <tr> <td>20.08.2012</td> <td>10:30:52</td> </tr> </table>             | $errV_b$                 | 000000000 m <sup>3</sup> | 20.08.2012 | 10:30:52                | $errV_b$ = Error volume at base conditions  |
| $errV_b$  | 000000000 m <sup>3</sup> |                          |            |                         |   |
| 20.08.2012  | 10:30:52                 |                          |            |                         |   |
| ↳ Pressing ENTER opens the action "Reset error volume".<br>→ "Resetting the error volume" (p. 91).  |                          |                          |            |                         |   |
| <table border="1"> <tr> <td><math>totalV_b</math></td> <td>000000000 m<sup>3</sup></td> </tr> <tr> <td>20.08.2012</td> <td>10:30:52</td> </tr> </table>           | $totalV_b$               | 000000000 m <sup>3</sup> | 20.08.2012 | 10:30:52                | $totalV_b$ = Total volume at base conditions = $V_b + errV_b$   |
| $totalV_b$  | 000000000 m <sup>3</sup> |                          |            |                         |   |
| 20.08.2012  | 10:30:52                 |                          |            |                         |   |
| <table border="1"> <tr> <td><math>V_m</math></td> <td>000000000 m<sup>3</sup></td> </tr> <tr> <td>20.08.2012</td> <td>10:30:52</td> </tr> </table>                | $V_m$                    | 000000000 m <sup>3</sup> | 20.08.2012 | 10:30:52                | $V_m$ = Total volume at measurement conditions  |
| $V_m$   | 000000000 m <sup>3</sup> |                          |            |                         |   |
| 20.08.2012  | 10:30:52                 |                          |            |                         |   |
| <table border="1"> <tr> <td><math>errV_m</math></td> <td>000000000 m<sup>3</sup></td> </tr> <tr> <td>20.08.2012</td> <td>10:30:52</td> </tr> </table>             | $errV_m$                 | 000000000 m <sup>3</sup> | 20.08.2012 | 10:30:52                | $errV_m$ = Error volume<br>Volume counted at measurement conditions, during a malfunction, can be reset |
| $errV_m$  | 000000000 m <sup>3</sup> |                          |            |                         |   |
| 20.08.2012  | 10:30:52                 |                          |            |                         |   |
| <table border="1"> <tr> <td><math>Q</math></td> <td>0.000 m<sup>3</sup>/h</td> </tr> <tr> <td><math>Q_b</math></td> <td>0.000 m<sup>3</sup>/h</td> </tr> </table> | $Q$                      | 0.000 m <sup>3</sup> /h  | $Q_b$      | 0.000 m <sup>3</sup> /h | $Q$ = Volume flow at measurement conditions<br>$Q_b$ = Volume flow at base conditions                   |
| $Q$   | 0.000 m <sup>3</sup> /h  |                          |            |                         |   |
| $Q_b$   | 0.000 m <sup>3</sup> /h  |                          |            |                         |   |
| <table border="1"> <tr> <td>SOS</td> <td>430.00 m/s</td> </tr> <tr> <td>VOG</td> <td>0.000 m/s</td> </tr> </table>  | SOS                      | 430.00 m/s               | VOG        | 0.000 m/s               | SOS = Sound velocity currently measured<br>VOG = Gas velocity currently measured                        |
| SOS   | 430.00 m/s               |                          |            |                         |   |
| VOG   | 0.000 m/s                |                          |            |                         |   |

| Main display   | Description  |
|--|--|
| <p><b>p</b>                    3.532 bar<br/><b>T</b>                    25.42 °C</p>  | <p>p = Pressure currently used for volume conversion<br/>T = Temperature currently used for volume conversion</p>  |
| <p><b>C</b>                    25.7368<br/><b>K</b>                    0.9541</p>  | <p>C = Conversion factor<br/>K = Compressibility factor</p>  |
| <p><b>Z</b>                    0.99830<br/><b>Zb</b>                  0.99812</p>  | <p>Z = Compression factor at measurement conditions currently used for volume conversion<br/>Zb = Compression factor at base conditions currently used for volume conversion</p> |
| <p><b>Current events</b><br/>1 Event</p>   | <p>Current events (1 event is reported)</p>  |
| <p>↳ Pressing ENTER opens a list of current reported events.<br/>Use the arrow buttons to toggle through the reported events.</p>  |  |
| <p><b>Event Summary</b><br/>2 Events</p>   | <p>Stored status messages: Events since the last time the event summary was reset (2 events have occurred).</p>  |
| <p>↳ Pressing ENTER opens a list of stored events.<br/>Use the arrow buttons to toggle through the stored events.</p>  |  |
| <p><b>Last Event Reset</b><br/>20.08.2012    10:30:52</p>  | <p>Last reset of event summary</p>   |
| <p>↳ Pressing ENTER opens the action "Reset Event Summary".<br/>→ "Resetting the event summary" (p. 91).</p>   |  |
| <p> <b>NOTICE:</b><br/>A parameter with Malfunction status is shown on the display by a blinking exclamation mark after the parameter (e. g. Q!).</p> |  |

**Menu navigation (with device option volume conversion)**

Some menu functions are only available when you are logged in with user level “User” or “Authorized User”:

|                |                    |                                    |  |
|----------------|--------------------|------------------------------------|--|
| User level:    | G Guest (standard) | U User (1)<br>User (2)<br>User (3) | A1 Authorized user (1)<br>A2 Authorized user (2)<br>A3 Authorized user (3) |
| Access rights: | - Hidden           | ○ View                             | ● Start/edit   |

| Path                                       | G | U | A2+3 | A1 | Explanation       |
|--|---|---|------|----|-------------------|
| <b>Main display: Base volume Vb</b>        | ○ | ○ | ○    | ○  |                   |
| <b>FLWSIC500 menu: User</b>                | ○ | ○ | ○    | ○  | → p. 85, §5.2.6.1 |
| Logged in user level                       | ● | ● | ●    | ●  |                   |
| Login                                      | ● | ● | ●    | ●  |                   |
| Logout                                     | - | ● | ●    | ●  |                   |
| <b>FLWSIC500 menu: Device mode</b>         | ○ | ○ | ○    | ○  | → p. 85, §5.2.6.2 |
| Calibration mode                           | ○ | ○ | ●    | ●  |                   |
| Configuration mode                         | ○ | ○ | ●    | ●  |                   |
| <b>FLWSIC500 menu: Device information</b>  | ○ | ○ | ○    | ○  | p. 85, §5.2.6.3   |
| Measuring port                             | ○ | ○ | ○    | ○  |                   |
| Serial number                              | ○ | ○ | ○    | ○  |                   |
| Firmware version                           | ○ | ○ | ○    | ○  |                   |
| Firmware date                              | ○ | ○ | ○    | ○  |                   |
| Firmware CRC                               | ○ | ○ | ○    | ○  |                   |
| Metrology CRC                              | ○ | ○ | ○    | ○  |                   |
| Min. oper. pressure                        | ○ | ○ | ○    | ○  |                   |
| Max. oper. pressure                        | ○ | ○ | ○    | ○  |                   |
| Meter factor                               | ○ | ○ | ○    | ○  |                   |
| Frequency at Qr                            | ○ | ○ | ○    | ○  |                   |
| Meter factor 2                             | ○ | ○ | ○    | ○  |                   |
| <b>FLWSIC500 menu: System settings</b>     | ○ | ○ | ○    | ○  | → p. 86, §5.2.6.4 |
| Power supply (1)                           | ○ | ○ | ●    | ●  |                   |
| Power supply (2)                           | ○ | ○ | ●    | ●  |                   |
| Date                                       | ○ | ○ | ●    | ●  |                   |
| Time                                       | ○ | ○ | ●    | ●  |                   |
| Timezone                                   | ○ | ○ | ●    | ●  |                   |
| Language                                   | ○ | ● | ●    | ●  |                   |
| Symbols                                    | ○ | ○ | ○    | ○  |                   |
| LCD test                                   | ○ | ● | ●    | ●  |                   |
| <b>FLWSIC500 menu: Conversion</b>          | ○ | ○ | ○    | ○  | → p. 87, §5.2.6.5 |
| Conversion: References                     | ○ | ○ | ○    | ○  |                   |
| Basic pressure                             | ○ | ○ | ●    | ●  |                   |
| Basic temperature                          | ○ | ○ | ●    | ●  |                   |
| Ref. conditions                            | ○ | ○ | ●    | ●  |                   |
| Atmospheric pressure                       | ○ | ○ | ●    | ●  |                   |
| Conversion: Calculation                    | ○ | ○ | ○    | ○  |                   |
| Calc. methods                              | ○ | ○ | ●    | ●  |                   |
| Calc. interval                             | ○ | ○ | ●    | ●  |                   |
| K-factor (fixed)                           | ○ | ○ | ●    | ●  |                   |
| Conversion: Gas composition                | ○ | ○ | ○    | ○  |                   |
| Density entry type                         | ○ | ○ | ●    | ●  |                   |
| Reference density                          | ○ | ○ | ●    | ●  |                   |
| Relative density                           | ○ | ○ | ●    | ●  |                   |
| CO2 [mol%]                                 | ○ | ○ | ●    | ●  |                   |
| N2 [mol%]                                  | ○ | ○ | ●    | ●  |                   |
| H2 [mol%]                                  | ○ | ○ | ●    | ●  |                   |
| Heating value                              | ○ | ○ | ●    | ●  |                   |
| Heating value unit                         | ○ | ○ | ●    | ●  |                   |
| <b>FLWSIC500 menu: Pressure parameters</b> | ○ | ○ | ○    | ○  | → p. 88, §5.2.6.6 |

| Path   | G | U | A2+3 | A1 | Explanation       |
|--|---|---|------|----|-------------------|
| p Sensor type                                  | ○ | ○ | ○    | ○  |                   |
| p Sensor serial number                         | ○ | ○ | ○    | ○  |                   |
| p Lower alarm limit                            | ○ | ○ | ●    | ●  |                   |
| p Upper alarm limit                            | ○ | ○ | ●    | ●  |                   |
| p Default value                                | ○ | ○ | ●    | ●  |                   |
| p Unit   | ○ | ○ | ●    | ●  |                   |
| p Adjust offset                                | ○ | ○ | ●    | ●  |                   |
| p Adjust factor                                | ○ | ○ | ●    | ●  |                   |
| <b>FLAWSIC500 menu: Temperature parameters</b> | ○ | ○ | ○    | ○  | → p. 88, §5.2.6.7 |
| T Sensor type                                  | ○ | ○ | ○    | ○  |                   |
| T Sensor serial number                         | ○ | ○ | ○    | ○  |                   |
| T Lower alarm limit                            | ○ | ○ | ●    | ●  |                   |
| T Upper alarm limit                            | ○ | ○ | ●    | ●  |                   |
| T Default value                                | ○ | ○ | ●    | ●  |                   |
| T Unit   | ○ | ○ | ●    | ●  |                   |
| T Adjust offset                                | ○ | ○ | ●    | ●  |                   |
| T Adjust factor                                | ○ | ○ | ●    | ●  |                   |
| <b>FLAWSIC500 menu: Logbooks</b>               | ○ | ○ | ○    | ○  |                   |
| Event logbook                                  | ○ | ○ | ○    | ○  |                   |
| List of stored events                          | - | ○ | ○    | ○  |                   |
| Parameter logbook                              | ○ | ○ | ○    | ○  |                   |
| Metrology logbook                              | ○ | ○ | ○    | ○  |                   |
| Gas composition logbook                        | ○ | ○ | ○    | ○  |                   |
| <b>FLAWSIC500 menu: Archives</b>               | ○ | ○ | ○    | ○  | → p. 89, §5.2.6.9 |
| Gas hour                                       | ○ | ○ | ●    | ●  |                   |
| Gas day  | ○ | ○ | ●    | ●  |                   |
| Measuring period                               | ○ | ○ | ●    | ●  |                   |
| <b>Main display: errVb</b>                     | ○ | ○ | ●    | ●  | → p. 91, §5.2.11  |
| <b>Main display: totalVb</b>                   | ○ | ○ | ○    | ○  |                   |
| <b>Main display: Vm</b>                        | ○ | ○ | ○    | ○  |                   |
| <b>Main display: errVm</b>                     | ○ | ○ | ○    | ○  |                   |
| <b>Main display: Q/Qb</b>                      | ○ | ○ | ○    | ○  |                   |
| <b>Main display: SOS/VOG</b>                   | ○ | ○ | ○    | ○  |                   |
| <b>Main display: p/T</b>                       | ○ | ○ | ○    | ○  |                   |
| <b>Main display: C-factor</b>                  | ○ | ○ | ○    | ○  |                   |
| <b>Main display: Z/Zb</b>                      | ○ | ○ | ○    | ○  |                   |
| <b>Main display: Current Events</b>            | ○ | ○ | ○    | ○  |                   |
| List of current events                         | ○ | ○ | ○    | ○  |                   |
| <b>Main display: Event Summary</b>             | ○ | ○ | ○    | ○  |                   |
| List of stored events                          | ○ | ○ | ○    | ○  |                   |
| <b>Main display: Last Event Reset</b>          | ○ | ○ | ●    | ●  | → p. 91, §5.2.12  |

### 5.2.5 Configuration of main display

The configuration of the main display can be performed using the FLOWgate™ operating software.

The following contents are available:

- Empty (line 1 - set at the factory)
- Date, time (line 2 - set at the factory)
- Pressure p
- Temperature T
- Conversion factor C
- Compressibility factor K
- Operational flow rate Q
- Flow rate Q<sub>b</sub> relative to the base conditions
- VOG
- SOS

#### Configuring

- 1 Connect to device, → p. 67, §4.3.1.
- 2 Open the tile “System/User” in the “Parameter Modification” area.
- 3 Start the configuration mode.
- 4 Select the desired parameters in the selection boxes “Contents display line” and “Contents bottom display line”.
- 5 Click “Write to device”.  
The parameters are written to the device and the display contents adjusted to match the selection.
- 6 Return to the operating mode.



5.2.6 **FLWSIC500 menu**

5.2.6.1 **User**

|      |  |
|------|--|
| User | <p>Logged in user level, without login: Guest<br/>→ “Changing the user level” (p. 90)</p> <p>Logged in as:</p> <ul style="list-style-type: none"> <li>● User (1)</li> <li>● User (2)*</li> <li>● User (3)*</li> <li>● Authorized user (1)</li> <li>● Authorized user (2)*</li> <li>● Authorized user (3)*</li> </ul> <p>* when activated</p> |
|------|--|

5.2.6.2 **Device mode**

|                    |  |
|--------------------|--|
| Calibration mode   | <p>Display whether calibration mode for the flow rate check is switched on or off, start and end calibration mode</p> <p>In calibration mode, message “CALIBRATION MODE” blinks on the main display with the meter factor now effective for the calibration (set at the factory).<br/>The FLOWSIC500 outputs test pulses with a maximum possible frequency of 2 kHz at 120% <math>Q_{max}</math> on digital switching output DO_1 (→ p. 48, §3.4.6.1).</p> <p>For flow rate check and calibration, see document “9193003: Calibration Instructions for the Ultrasonic Gas Flow Meter FLOWSIC500”</p> |
| Configuration mode | <p>Display whether configuration mode is switched on or off, Starting and terminating configuration mode</p> <p>→ “Start configuration mode” (p. 90)</p>   |

5.2.6.3 **Device information**

|                             |  |
|-----------------------------|--|
| Measuring port              | Measuring port identifier  |
| Serial number               | Device serial number   |
| Firmware Version            | Firmware version installed on the device   |
| Firmware Date               | Firmware release date  |
| Firmware CRC                | Firmware check sum   |
| Metrology CRC               | Check sum of metrologically relevant parameters  |
| Min. oper. pressure         | Minimum operating overpressure   |
| Max. oper. pressure         | Maximum operating overpressure   |
| Meter factor                | Pulse valency, relation between frequency and flow rate [Imp/m <sup>3</sup> ]  |
| Frequency at Q <sub>r</sub> | Frequency for overload flow rate $Q_r = 1,2 Q_{max}$   |
| Meter factor 2              | Pulse valency, relation between frequency and flow rate [Imp/m <sup>3</sup> ], for second pulse output (for interface configuration L, 2 x NF pulse) |

5.2.6.4

**System settings**

| Power supply (1)          | <ul style="list-style-type: none"> <li>● For battery operation:                             <ul style="list-style-type: none"> <li>- Fill level for battery pack 1 [%],</li> <li>- Confirm battery exchange for battery pack 1.</li> </ul>                             → “Confirming battery replacement” (p. 92)                         </li> <li>● With external power supply:                             <ul style="list-style-type: none"> <li>- Display: 100%</li> </ul>                             → “Checking the external power supply” (p. 92)                         </li> </ul>  |     |         |     |      |     |                      |   |   |   |    |                         |   |   |   |    |                 |     |     |     |     |                |     |     |     |     |  |         |     |      |     |                      |    |    |   |    |               |    |    |    |    |                         |   |   |   |    |                  |    |    |    |    |                        |   |   |   |    |                 |    |    |    |    |                           |   |   |   |    |                    |    |    |    |    |                 |     |     |     |     |                |     |     |     |     |                  |   |   |   |   |                   |   |   |   |   |                 |   |   |   |    |          |    |    |    |    |
|---------------------------|---|-----|---------|-----|------|-----|----------------------|---|---|---|----|-------------------------|---|---|---|----|-----------------|-----|-----|-----|-----|----------------|-----|-----|-----|-----|--|---------|-----|------|-----|----------------------|----|----|---|----|---------------|----|----|----|----|-------------------------|---|---|---|----|------------------|----|----|----|----|------------------------|---|---|---|----|-----------------|----|----|----|----|---------------------------|---|---|---|----|--------------------|----|----|----|----|-----------------|-----|-----|-----|-----|----------------|-----|-----|-----|-----|------------------|---|---|---|---|-------------------|---|---|---|---|-----------------|---|---|---|----|----------|----|----|----|----|
| Power supply (2)          | <ul style="list-style-type: none"> <li>● For battery operation:                             <ul style="list-style-type: none"> <li>- Fill level for battery pack 2 [%],</li> <li>- Confirm battery exchange for battery pack 2.</li> </ul> </li> <li>● With external power supply:                             <ul style="list-style-type: none"> <li>- Fill level for backup battery</li> <li>- Confirm battery exchange for backup battery.</li> </ul> </li> </ul> → “Confirming battery replacement” (p. 92)   |     |         |     |      |     |                      |   |   |   |    |                         |   |   |   |    |                 |     |     |     |     |                |     |     |     |     |  |         |     |      |     |                      |    |    |   |    |               |    |    |    |    |                         |   |   |   |    |                  |    |    |    |    |                        |   |   |   |    |                 |    |    |    |    |                           |   |   |   |    |                    |    |    |    |    |                 |     |     |     |     |                |     |     |     |     |                  |   |   |   |   |                   |   |   |   |   |                 |   |   |   |    |          |    |    |    |    |
| Date                      | Device date → “Commissioning on the display” (p. 64)  |     |         |     |      |     |                      |   |   |   |    |                         |   |   |   |    |                 |     |     |     |     |                |     |     |     |     |  |         |     |      |     |                      |    |    |   |    |               |    |    |    |    |                         |   |   |   |    |                  |    |    |    |    |                        |   |   |   |    |                 |    |    |    |    |                           |   |   |   |    |                    |    |    |    |    |                 |     |     |     |     |                |     |     |     |     |                  |   |   |   |   |                   |   |   |   |   |                 |   |   |   |    |          |    |    |    |    |
| Time                      | Device time → “Commissioning on the display” (p. 64)  |     |         |     |      |     |                      |   |   |   |    |                         |   |   |   |    |                 |     |     |     |     |                |     |     |     |     |  |         |     |      |     |                      |    |    |   |    |               |    |    |    |    |                         |   |   |   |    |                  |    |    |    |    |                        |   |   |   |    |                 |    |    |    |    |                           |   |   |   |    |                    |    |    |    |    |                 |     |     |     |     |                |     |     |     |     |                  |   |   |   |   |                   |   |   |   |   |                 |   |   |   |    |          |    |    |    |    |
| Timezone                  | Time zone set on device   |     |         |     |      |     |                      |   |   |   |    |                         |   |   |   |    |                 |     |     |     |     |                |     |     |     |     |  |         |     |      |     |                      |    |    |   |    |               |    |    |    |    |                         |   |   |   |    |                  |    |    |    |    |                        |   |   |   |    |                 |    |    |    |    |                           |   |   |   |    |                    |    |    |    |    |                 |     |     |     |     |                |     |     |     |     |                  |   |   |   |   |                   |   |   |   |   |                 |   |   |   |    |          |    |    |    |    |
| Language                  | Language for displays<br>Available: English, German, Russian<br><br>→ “Setting the language” (p. 90)  |     |         |     |      |     |                      |   |   |   |    |                         |   |   |   |    |                 |     |     |     |     |                |     |     |     |     |  |         |     |      |     |                      |    |    |   |    |               |    |    |    |    |                         |   |   |   |    |                  |    |    |    |    |                        |   |   |   |    |                 |    |    |    |    |                           |   |   |   |    |                    |    |    |    |    |                 |     |     |     |     |                |     |     |     |     |                  |   |   |   |   |                   |   |   |   |   |                 |   |   |   |    |          |    |    |    |    |
| Symbols according to      | Symbols for the Measuring screens, the setting can be changed with the FLOWgate™ operating software.<br>Gas flow meter: <table border="1" style="width: 100%; border-collapse: collapse; text-align: center;"> <thead> <tr> <th></th> <th>EN12405</th> <th>PTB</th> <th>GOST</th> <th>API</th> </tr> </thead> <tbody> <tr> <td>Volume (measurement)</td> <td>V</td> <td>V</td> <td>V</td> <td>Vf</td> </tr> <tr> <td>Flow rate (operational)</td> <td>Q</td> <td>Q</td> <td>Q</td> <td>Qb</td> </tr> <tr> <td>Velocity of Gas</td> <td>VOG</td> <td>VOG</td> <td>VOG</td> <td>VOG</td> </tr> <tr> <td>Speed of Sound</td> <td>SOS</td> <td>SOS</td> <td>SOS</td> <td>SOS</td> </tr> </tbody> </table><br>Gas flow meter with volume conversion: <table border="1" style="width: 100%; border-collapse: collapse; text-align: center;"> <thead> <tr> <th></th> <th>EN12405</th> <th>PTB</th> <th>GOST</th> <th>API</th> </tr> </thead> <tbody> <tr> <td>Volume (measurement)</td> <td>Vm</td> <td>Vm</td> <td>V</td> <td>Vf</td> </tr> <tr> <td>Volume (base)</td> <td>Vb</td> <td>Vb</td> <td>Vc</td> <td>Vb</td> </tr> <tr> <td>Flow rate (operational)</td> <td>Q</td> <td>Q</td> <td>Q</td> <td>Qb</td> </tr> <tr> <td>Flow rate (base)</td> <td>Qf</td> <td>Qf</td> <td>Qc</td> <td>Qf</td> </tr> <tr> <td>Pressure (measurement)</td> <td>p</td> <td>p</td> <td>P</td> <td>Pf</td> </tr> <tr> <td>Pressure (base)</td> <td>pb</td> <td>pb</td> <td>Pc</td> <td>Pb</td> </tr> <tr> <td>Temperature (measurement)</td> <td>T</td> <td>T</td> <td>T</td> <td>Tf</td> </tr> <tr> <td>Temperature (base)</td> <td>Tb</td> <td>Tb</td> <td>TC</td> <td>Tb</td> </tr> <tr> <td>Velocity of Gas</td> <td>VOG</td> <td>VOG</td> <td>VOG</td> <td>VOG</td> </tr> <tr> <td>Speed of Sound</td> <td>SOS</td> <td>SOS</td> <td>SOS</td> <td>SOS</td> </tr> <tr> <td>K-factor (fixed)</td> <td>K</td> <td>K</td> <td>K</td> <td>s</td> </tr> <tr> <td>Conversion factor</td> <td>C</td> <td>C</td> <td>C</td> <td>C</td> </tr> <tr> <td>Z (measurement)</td> <td>Z</td> <td>Z</td> <td>Z</td> <td>Zf</td> </tr> <tr> <td>Z (base)</td> <td>Zb</td> <td>Zb</td> <td>Zc</td> <td>Zb</td> </tr> </tbody> </table> |     | EN12405 | PTB | GOST | API | Volume (measurement) | V | V | V | Vf | Flow rate (operational) | Q | Q | Q | Qb | Velocity of Gas | VOG | VOG | VOG | VOG | Speed of Sound | SOS | SOS | SOS | SOS |  | EN12405 | PTB | GOST | API | Volume (measurement) | Vm | Vm | V | Vf | Volume (base) | Vb | Vb | Vc | Vb | Flow rate (operational) | Q | Q | Q | Qb | Flow rate (base) | Qf | Qf | Qc | Qf | Pressure (measurement) | p | p | P | Pf | Pressure (base) | pb | pb | Pc | Pb | Temperature (measurement) | T | T | T | Tf | Temperature (base) | Tb | Tb | TC | Tb | Velocity of Gas | VOG | VOG | VOG | VOG | Speed of Sound | SOS | SOS | SOS | SOS | K-factor (fixed) | K | K | K | s | Conversion factor | C | C | C | C | Z (measurement) | Z | Z | Z | Zf | Z (base) | Zb | Zb | Zc | Zb |
|                           | EN12405   | PTB | GOST    | API |      |     |                      |   |   |   |    |                         |   |   |   |    |                 |     |     |     |     |                |     |     |     |     |  |         |     |      |     |                      |    |    |   |    |               |    |    |    |    |                         |   |   |   |    |                  |    |    |    |    |                        |   |   |   |    |                 |    |    |    |    |                           |   |   |   |    |                    |    |    |    |    |                 |     |     |     |     |                |     |     |     |     |                  |   |   |   |   |                   |   |   |   |   |                 |   |   |   |    |          |    |    |    |    |
| Volume (measurement)      | V   | V   | V       | Vf  |      |     |                      |   |   |   |    |                         |   |   |   |    |                 |     |     |     |     |                |     |     |     |     |  |         |     |      |     |                      |    |    |   |    |               |    |    |    |    |                         |   |   |   |    |                  |    |    |    |    |                        |   |   |   |    |                 |    |    |    |    |                           |   |   |   |    |                    |    |    |    |    |                 |     |     |     |     |                |     |     |     |     |                  |   |   |   |   |                   |   |   |   |   |                 |   |   |   |    |          |    |    |    |    |
| Flow rate (operational)   | Q   | Q   | Q       | Qb  |      |     |                      |   |   |   |    |                         |   |   |   |    |                 |     |     |     |     |                |     |     |     |     |  |         |     |      |     |                      |    |    |   |    |               |    |    |    |    |                         |   |   |   |    |                  |    |    |    |    |                        |   |   |   |    |                 |    |    |    |    |                           |   |   |   |    |                    |    |    |    |    |                 |     |     |     |     |                |     |     |     |     |                  |   |   |   |   |                   |   |   |   |   |                 |   |   |   |    |          |    |    |    |    |
| Velocity of Gas           | VOG   | VOG | VOG     | VOG |      |     |                      |   |   |   |    |                         |   |   |   |    |                 |     |     |     |     |                |     |     |     |     |  |         |     |      |     |                      |    |    |   |    |               |    |    |    |    |                         |   |   |   |    |                  |    |    |    |    |                        |   |   |   |    |                 |    |    |    |    |                           |   |   |   |    |                    |    |    |    |    |                 |     |     |     |     |                |     |     |     |     |                  |   |   |   |   |                   |   |   |   |   |                 |   |   |   |    |          |    |    |    |    |
| Speed of Sound            | SOS   | SOS | SOS     | SOS |      |     |                      |   |   |   |    |                         |   |   |   |    |                 |     |     |     |     |                |     |     |     |     |  |         |     |      |     |                      |    |    |   |    |               |    |    |    |    |                         |   |   |   |    |                  |    |    |    |    |                        |   |   |   |    |                 |    |    |    |    |                           |   |   |   |    |                    |    |    |    |    |                 |     |     |     |     |                |     |     |     |     |                  |   |   |   |   |                   |   |   |   |   |                 |   |   |   |    |          |    |    |    |    |
|                           | EN12405   | PTB | GOST    | API |      |     |                      |   |   |   |    |                         |   |   |   |    |                 |     |     |     |     |                |     |     |     |     |  |         |     |      |     |                      |    |    |   |    |               |    |    |    |    |                         |   |   |   |    |                  |    |    |    |    |                        |   |   |   |    |                 |    |    |    |    |                           |   |   |   |    |                    |    |    |    |    |                 |     |     |     |     |                |     |     |     |     |                  |   |   |   |   |                   |   |   |   |   |                 |   |   |   |    |          |    |    |    |    |
| Volume (measurement)      | Vm  | Vm  | V       | Vf  |      |     |                      |   |   |   |    |                         |   |   |   |    |                 |     |     |     |     |                |     |     |     |     |  |         |     |      |     |                      |    |    |   |    |               |    |    |    |    |                         |   |   |   |    |                  |    |    |    |    |                        |   |   |   |    |                 |    |    |    |    |                           |   |   |   |    |                    |    |    |    |    |                 |     |     |     |     |                |     |     |     |     |                  |   |   |   |   |                   |   |   |   |   |                 |   |   |   |    |          |    |    |    |    |
| Volume (base)             | Vb  | Vb  | Vc      | Vb  |      |     |                      |   |   |   |    |                         |   |   |   |    |                 |     |     |     |     |                |     |     |     |     |  |         |     |      |     |                      |    |    |   |    |               |    |    |    |    |                         |   |   |   |    |                  |    |    |    |    |                        |   |   |   |    |                 |    |    |    |    |                           |   |   |   |    |                    |    |    |    |    |                 |     |     |     |     |                |     |     |     |     |                  |   |   |   |   |                   |   |   |   |   |                 |   |   |   |    |          |    |    |    |    |
| Flow rate (operational)   | Q   | Q   | Q       | Qb  |      |     |                      |   |   |   |    |                         |   |   |   |    |                 |     |     |     |     |                |     |     |     |     |  |         |     |      |     |                      |    |    |   |    |               |    |    |    |    |                         |   |   |   |    |                  |    |    |    |    |                        |   |   |   |    |                 |    |    |    |    |                           |   |   |   |    |                    |    |    |    |    |                 |     |     |     |     |                |     |     |     |     |                  |   |   |   |   |                   |   |   |   |   |                 |   |   |   |    |          |    |    |    |    |
| Flow rate (base)          | Qf  | Qf  | Qc      | Qf  |      |     |                      |   |   |   |    |                         |   |   |   |    |                 |     |     |     |     |                |     |     |     |     |  |         |     |      |     |                      |    |    |   |    |               |    |    |    |    |                         |   |   |   |    |                  |    |    |    |    |                        |   |   |   |    |                 |    |    |    |    |                           |   |   |   |    |                    |    |    |    |    |                 |     |     |     |     |                |     |     |     |     |                  |   |   |   |   |                   |   |   |   |   |                 |   |   |   |    |          |    |    |    |    |
| Pressure (measurement)    | p   | p   | P       | Pf  |      |     |                      |   |   |   |    |                         |   |   |   |    |                 |     |     |     |     |                |     |     |     |     |  |         |     |      |     |                      |    |    |   |    |               |    |    |    |    |                         |   |   |   |    |                  |    |    |    |    |                        |   |   |   |    |                 |    |    |    |    |                           |   |   |   |    |                    |    |    |    |    |                 |     |     |     |     |                |     |     |     |     |                  |   |   |   |   |                   |   |   |   |   |                 |   |   |   |    |          |    |    |    |    |
| Pressure (base)           | pb  | pb  | Pc      | Pb  |      |     |                      |   |   |   |    |                         |   |   |   |    |                 |     |     |     |     |                |     |     |     |     |  |         |     |      |     |                      |    |    |   |    |               |    |    |    |    |                         |   |   |   |    |                  |    |    |    |    |                        |   |   |   |    |                 |    |    |    |    |                           |   |   |   |    |                    |    |    |    |    |                 |     |     |     |     |                |     |     |     |     |                  |   |   |   |   |                   |   |   |   |   |                 |   |   |   |    |          |    |    |    |    |
| Temperature (measurement) | T   | T   | T       | Tf  |      |     |                      |   |   |   |    |                         |   |   |   |    |                 |     |     |     |     |                |     |     |     |     |  |         |     |      |     |                      |    |    |   |    |               |    |    |    |    |                         |   |   |   |    |                  |    |    |    |    |                        |   |   |   |    |                 |    |    |    |    |                           |   |   |   |    |                    |    |    |    |    |                 |     |     |     |     |                |     |     |     |     |                  |   |   |   |   |                   |   |   |   |   |                 |   |   |   |    |          |    |    |    |    |
| Temperature (base)        | Tb  | Tb  | TC      | Tb  |      |     |                      |   |   |   |    |                         |   |   |   |    |                 |     |     |     |     |                |     |     |     |     |  |         |     |      |     |                      |    |    |   |    |               |    |    |    |    |                         |   |   |   |    |                  |    |    |    |    |                        |   |   |   |    |                 |    |    |    |    |                           |   |   |   |    |                    |    |    |    |    |                 |     |     |     |     |                |     |     |     |     |                  |   |   |   |   |                   |   |   |   |   |                 |   |   |   |    |          |    |    |    |    |
| Velocity of Gas           | VOG   | VOG | VOG     | VOG |      |     |                      |   |   |   |    |                         |   |   |   |    |                 |     |     |     |     |                |     |     |     |     |  |         |     |      |     |                      |    |    |   |    |               |    |    |    |    |                         |   |   |   |    |                  |    |    |    |    |                        |   |   |   |    |                 |    |    |    |    |                           |   |   |   |    |                    |    |    |    |    |                 |     |     |     |     |                |     |     |     |     |                  |   |   |   |   |                   |   |   |   |   |                 |   |   |   |    |          |    |    |    |    |
| Speed of Sound            | SOS   | SOS | SOS     | SOS |      |     |                      |   |   |   |    |                         |   |   |   |    |                 |     |     |     |     |                |     |     |     |     |  |         |     |      |     |                      |    |    |   |    |               |    |    |    |    |                         |   |   |   |    |                  |    |    |    |    |                        |   |   |   |    |                 |    |    |    |    |                           |   |   |   |    |                    |    |    |    |    |                 |     |     |     |     |                |     |     |     |     |                  |   |   |   |   |                   |   |   |   |   |                 |   |   |   |    |          |    |    |    |    |
| K-factor (fixed)          | K   | K   | K       | s   |      |     |                      |   |   |   |    |                         |   |   |   |    |                 |     |     |     |     |                |     |     |     |     |  |         |     |      |     |                      |    |    |   |    |               |    |    |    |    |                         |   |   |   |    |                  |    |    |    |    |                        |   |   |   |    |                 |    |    |    |    |                           |   |   |   |    |                    |    |    |    |    |                 |     |     |     |     |                |     |     |     |     |                  |   |   |   |   |                   |   |   |   |   |                 |   |   |   |    |          |    |    |    |    |
| Conversion factor         | C   | C   | C       | C   |      |     |                      |   |   |   |    |                         |   |   |   |    |                 |     |     |     |     |                |     |     |     |     |  |         |     |      |     |                      |    |    |   |    |               |    |    |    |    |                         |   |   |   |    |                  |    |    |    |    |                        |   |   |   |    |                 |    |    |    |    |                           |   |   |   |    |                    |    |    |    |    |                 |     |     |     |     |                |     |     |     |     |                  |   |   |   |   |                   |   |   |   |   |                 |   |   |   |    |          |    |    |    |    |
| Z (measurement)           | Z   | Z   | Z       | Zf  |      |     |                      |   |   |   |    |                         |   |   |   |    |                 |     |     |     |     |                |     |     |     |     |  |         |     |      |     |                      |    |    |   |    |               |    |    |    |    |                         |   |   |   |    |                  |    |    |    |    |                        |   |   |   |    |                 |    |    |    |    |                           |   |   |   |    |                    |    |    |    |    |                 |     |     |     |     |                |     |     |     |     |                  |   |   |   |   |                   |   |   |   |   |                 |   |   |   |    |          |    |    |    |    |
| Z (base)                  | Zb  | Zb  | Zc      | Zb  |      |     |                      |   |   |   |    |                         |   |   |   |    |                 |     |     |     |     |                |     |     |     |     |  |         |     |      |     |                      |    |    |   |    |               |    |    |    |    |                         |   |   |   |    |                  |    |    |    |    |                        |   |   |   |    |                 |    |    |    |    |                           |   |   |   |    |                    |    |    |    |    |                 |     |     |     |     |                |     |     |     |     |                  |   |   |   |   |                   |   |   |   |   |                 |   |   |   |    |          |    |    |    |    |
| LCD test                  | Display test → “Testing the display” (p. 92)  |     |         |     |      |     |                      |   |   |   |    |                         |   |   |   |    |                 |     |     |     |     |                |     |     |     |     |  |         |     |      |     |                      |    |    |   |    |               |    |    |    |    |                         |   |   |   |    |                  |    |    |    |    |                        |   |   |   |    |                 |    |    |    |    |                           |   |   |   |    |                    |    |    |    |    |                 |     |     |     |     |                |     |     |     |     |                  |   |   |   |   |                   |   |   |   |   |                 |   |   |   |    |          |    |    |    |    |

5.2.6.5 Conversion (only for device types with volume conversion)

References

| Basic pressure       | Basic pressure [unit acc. to display]   |       |                 |    |    |       |       |      |                 |       |      |      |                 |       |       |       |                 |       |       |       |                 |       |       |       |                 |       |       |       |                 |
|----------------------|---|-------|-----------------|----|----|-------|-------|------|-----------------|-------|------|------|-----------------|-------|-------|-------|-----------------|-------|-------|-------|-----------------|-------|-------|-------|-----------------|-------|-------|-------|-----------------|
| Basic temperature    | Basic temperature [unit acc. to display]  |       |                 |    |    |       |       |      |                 |       |      |      |                 |       |       |       |                 |       |       |       |                 |       |       |       |                 |       |       |       |                 |
| Ref. conditions      | <p>Reference conditions for density and heating value<br/>Display: T1/T2/p2</p> <p>T1 = Reference temperature, heating value<br/>T2 = Reference temperature, rel. density/reference density<br/>p2 = Reference pressure, rel. density/reference density</p> <table border="1"> <thead> <tr> <th></th> <th>T1</th> <th>T2</th> <th>p2</th> </tr> </thead> <tbody> <tr> <td>Set 1</td> <td>25 °C</td> <td>0 °C</td> <td>1.01325 bar (a)</td> </tr> <tr> <td>Set 2</td> <td>0 °C</td> <td>0 °C</td> <td>1.01325 bar (a)</td> </tr> <tr> <td>Set 3</td> <td>15 °C</td> <td>15 °C</td> <td>1.01325 bar (a)</td> </tr> <tr> <td>Set 4</td> <td>60 °F</td> <td>60 °F</td> <td>14,7347 psi (a)</td> </tr> <tr> <td>Set 5</td> <td>60 °F</td> <td>60 °F</td> <td>14.7300 psi (a)</td> </tr> <tr> <td>Set 6</td> <td>25 °C</td> <td>20 °C</td> <td>1.01325 bar (a)</td> </tr> </tbody> </table> |       | T1              | T2 | p2 | Set 1 | 25 °C | 0 °C | 1.01325 bar (a) | Set 2 | 0 °C | 0 °C | 1.01325 bar (a) | Set 3 | 15 °C | 15 °C | 1.01325 bar (a) | Set 4 | 60 °F | 60 °F | 14,7347 psi (a) | Set 5 | 60 °F | 60 °F | 14.7300 psi (a) | Set 6 | 25 °C | 20 °C | 1.01325 bar (a) |
|                      | T1  | T2    | p2              |    |    |       |       |      |                 |       |      |      |                 |       |       |       |                 |       |       |       |                 |       |       |       |                 |       |       |       |                 |
| Set 1                | 25 °C   | 0 °C  | 1.01325 bar (a) |    |    |       |       |      |                 |       |      |      |                 |       |       |       |                 |       |       |       |                 |       |       |       |                 |       |       |       |                 |
| Set 2                | 0 °C  | 0 °C  | 1.01325 bar (a) |    |    |       |       |      |                 |       |      |      |                 |       |       |       |                 |       |       |       |                 |       |       |       |                 |       |       |       |                 |
| Set 3                | 15 °C   | 15 °C | 1.01325 bar (a) |    |    |       |       |      |                 |       |      |      |                 |       |       |       |                 |       |       |       |                 |       |       |       |                 |       |       |       |                 |
| Set 4                | 60 °F   | 60 °F | 14,7347 psi (a) |    |    |       |       |      |                 |       |      |      |                 |       |       |       |                 |       |       |       |                 |       |       |       |                 |       |       |       |                 |
| Set 5                | 60 °F   | 60 °F | 14.7300 psi (a) |    |    |       |       |      |                 |       |      |      |                 |       |       |       |                 |       |       |       |                 |       |       |       |                 |       |       |       |                 |
| Set 6                | 25 °C   | 20 °C | 1.01325 bar (a) |    |    |       |       |      |                 |       |      |      |                 |       |       |       |                 |       |       |       |                 |       |       |       |                 |       |       |       |                 |
| Atmospheric pressure | <p>Ambient pressure [unit acc. to display]<br/>Input required for version with relative pressure sensor</p>   |       |                 |    |    |       |       |      |                 |       |      |      |                 |       |       |       |                 |       |       |       |                 |       |       |       |                 |       |       |       |                 |

Calculation

|                      |  |
|----------------------|--|
| Calculation method   | <p>Calculation method for the compressibility factor<br/>Select from:</p> <ul style="list-style-type: none"> <li>● SGERG88,</li> <li>● AGA 8 Gross method 1</li> <li>● AGA 8 Gross method 2</li> <li>● AGA NX-19</li> <li>● AGA NX-19 mod.</li> <li>● AGA NX-19 mod. GOST</li> <li>● GERG91 mod.</li> <li>● Fixed value</li> </ul> |
| Calculation interval | <p>Cycle time for updating measured values (pressure, temperature), calculation of the compressibility factor</p> <p>Select from: 3 s, 10 s, 20 s, 30 s, 60 s</p>  |
| K-factor (fixed)     | <p>Entry of K factor for method "Fixed value" when the calculation of the K-factor is incorrect.</p>   |

Gas composition (only for device option volume conversion)

|                    |   |
|--------------------|---|
| Density entry type | <p>Select from:<br/>Reference density, relative density<br/>Either menu item "Reference density" or menu item "Relative density" is displayed depending on the selection.</p>   |
| Reference density  | Gas reference density under reference conditions  |
| Relative density   | Relative density, relation between gas density and air density under reference conditions   |
| CO2                | CO <sub>2</sub> - proportion in gas [mol%]  |
| N2                 | N <sub>2</sub> - proportion in gas [mol%]   |
| H2                 | H <sub>2</sub> - proportion in gas [mol%]   |
| Heating value      | Gas heating (under reference conditions)  |
| Heating value unit | <p>Heating value unit<br/>Select from: Default, MJ/m<sup>3</sup>, kWh/m<sup>3</sup>, BTU/ft<sup>3</sup></p> <p>Default = Standard setting according to selected unit system (SI or US), configured in accordance with the order</p> |

Subject to change without notice



The calculation method selected determines the permissible entry limits for gas proportions as well as pressure and temperature.

## 5.2.6.6

**Pressure parameters (only for device option volume conversion)**

|                        |   |
|------------------------|---|
| p Sensor type          | Display of configured pressure sensor   |
| p Sensor serial number | Pressure sensor serial number expected by the device, preset  |
| p Lower alarm limit    | Lower alarm limit for pressure sensor   |
| p Upper alarm limit    | Upper alarm limit for pressure sensor   |
| p Default value        | Fixed value for measurement pressure [unit acc. to display]<br><br>The entry value is used as fixed value for configuration as TZ conversion and for pressure measurement malfunctions.   |
| p Unit                 | Unit for pressure values, used for entry and display<br>Select from:<br>Default, bar, psia, kPa, MPa, kg/cm <sup>2</sup> , psig<br>Default = Standard setting according to selected unit system (SI or Imperial), configured in accordance with the order |
| p Adjust offset        | Calibration offset for pressure sensor [unit acc. to display]   |
| p Adjust factor        | Calibration factor for pressure sensor  |

## 5.2.6.7

**Temperature parameters (only for device option volume conversion)**

|                        |  |
|------------------------|--|
| T Sensor type          | Display of configured temperature sensor   |
| T Sensor serial number | Temperature sensor serial number expected by the device, preset  |
| T Lower alarm limit    | Lower alarm limit for temperature sensor   |
| T Upper alarm limit    | Upper alarm limit for temperature sensor   |
| T Default value        | Fixed value for measurement temperature [unit acc. to display]<br><br>The entry value is used as fixed value for malfunctions of temperature measurement.  |
| T Unit                 | Unit for temperature values, used for entry and display<br>Select from:<br>Default, ° C, ° F, K, ° R<br><br>Default = Standard setting according to selected unit system (SI or Imperial), configured in accordance with the order |
| T Adjust offset        | Calibration offset for temperature sensor [unit acc. to display]   |
| T Adjust factor        | Calibration factor for temperature sensor  |

## 5.2.6.8

**Logbooks**

|                         |  |
|-------------------------|--|
| Event logbook           | Number of entries currently stored/max. number<br>Pressing ENTER opens the detailed view.<br>The detailed view shows the event type, a short text and the timestamp. |
| Parameter logbook       | Number of entries currently stored/max. number   |
| Metrology logbook       | Number of entries currently stored/max. number   |
| Gas composition logbook | Number of entries currently stored/max. number   |

5.2.6.9

**Archives**

|                  |  |
|------------------|--|
| Gas hour         | Billing hour for the day archive<br>Entry range: 00:00 ... 23:59<br>Default: 06:00                                 |
| Gas day          | Billing day for month archive<br>Measuring range: 1 ... 28<br>Default: 1   |
| Measuring period | Defines the period for the billing archive<br>Select from: 3 min, 5 min, 15 min, 30 min, 60 min<br>Default: 60 min |

### 5.2.7 Changing the user level

- 1 Call up menu function "User".
- 2 Press ENTER to start the edit mode.
- 3 Use the arrow buttons to select the desired user level.
- 4 Confirm with ENTER.  
The cursor now blinks under the first position of the password.
- 5 To enter the password:
  - Use the arrow buttons to increment or decrement the first position of the password by 1 until the correct digit is shown.
  - Confirm with ENTER.  
The cursor now blinks under the second position of the password.
  - Repeat for the remaining positions of the password.
  - You are logged in with the selected user level after the last position of the password is confirmed.



The following users are set at the factory:

- User (1), password: 1111
- Authorized user (1), password: 2222

► Change the password after the first logon using the FLOWgate™ operating software.

### 5.2.8 Setting the language

- 1 Switch to the "System settings" submenu in the FLOWSIC500 menu.
- 2 Call up "Language".
- 3 Press ENTER to start the edit mode.
- 4 Use the arrow buttons to select the desired language.
- 5 Confirm with ENTER.  
The display texts are now shown in the selected language.

### 5.2.9 Changing the device mode

On the FLOWSIC500, the device modes Configuration and Calibration can be activated independently from each other.

#### 5.2.9.1 Starting and terminating configuration mode

##### Start configuration mode

- 1 Switch to the "Device mode" submenu in the FLOWSIC500 menu.
- 2 Call up "Configuration mode".
- 3 Press ENTER to start the edit mode.
- 4 Use the arrow buttons to select ON.
- 5 Confirm with ENTER.

The configuration mode is started.

Symbol  is displayed in the symbol bar.

##### Terminate configuration mode

- 1 Call up "Configuration mode".
- 2 Use the arrow buttons to select OFF.
- 3 Confirm with ENTER.

The configuration mode is terminated.

### 5.2.9.2 Starting and terminating calibration mode

Calibration mode can be started and terminated in the same manner as the configuration mode (→ p. 91, § 5.2.9.2).

In calibration mode, message “CALIBRATION MODE” blinks on the main display with the meter factor now effective for the calibration (set at the factory).

The FLOWSIC500 outputs test pulses with a maximum possible frequency of 2 kHz at 120%  $Q_{max}$  on digital switching output DO\_1 (→ p. 34, § 3.4.6.1).

### 5.2.10 Changing parameters

#### Numerical values

- 1 Start the configuration mode (→ p. 90).
- 2 Select the desired parameter in the menu.
- 3 Press ENTER to start the edit mode.  
The cursor now blinks under the first position of the parameter.
- 4 Use the arrow buttons to increment or decrement the selected position by 1 until the correct digit is shown.
- 5 Confirm with ENTER.  
The cursor now blinks under the second position of the parameter.
- 6 Repeat for all remaining positions of the parameter.

#### Selection lists

- 1 Start the configuration mode (→ p. 90).
- 2 Select the desired parameter in the menu.
- 3 Press ENTER to start the edit mode.
- 4 use the arrow buttons to switch to the desired selection.
- 5 Confirm with ENTER.

### 5.2.11 Resetting the error volume

- 1 Switch to the error volume display on the main screen.
- 2 Press ENTER to start the edit mode.
- 3 Use the arrow buttons to select OK.
- 4 Confirm with ENTER.  
The error volume is reset.

### 5.2.12 Resetting the event summary

- 1 Switch to the “Event Summary” display on the main display.
- 2 Press ENTER to open a list of the stored events.
- 3 Press ENTER to start the edit mode.
- 4 Use the arrow buttons to select OK.
- 5 Confirm with ENTER.  
The event summary is reset.

### 5.2.13 **Confirming battery replacement**

Confirm battery replacement on the display after you have changed a battery.

- 1 Switch to the “System settings” submenu in the FLOWSIC500 menu.
- 2 Switch to the status indicator of the replaced batteries, e.g. “Power Supply (1)”.
- 3 Press ENTER to start the edit mode.
- 4 Use the arrow buttons to select OK.
- 5 Confirm with ENTER.

### 5.2.14 **Checking the external power supply**

An external power supply connected to the meter can be checked as follows:

- 1 Switch to the “System settings” submenu in the FLOWSIC500 menu.
- 2 Select “Power supply (1)” with the arrow buttons and confirm with ENTER.
- 3 Select “Check ext.power supply” and confirm with ENTER.

### 5.2.15 **Testing the display**

- 1 Switch to the “System settings” submenu in the FLOWSIC500 menu.
- 2 Call up “LCD Test”.
- 3 Press ENTER to start the display test.

All display segments on the display are activated and deactivated three times. Defective display segments can thus be detected.



# FLWSIC500

## 6 Clearing malfunctions

Contacting Customer Service

Status messages

Additional messages in the Event logbook

Starting a diagnostic session

## 6.1 Contacting Customer Service



Contact SICK Customer Service for any malfunctions you cannot clear yourself.



To help Customer Service understand malfunctions that have occurred, the FLOWgate™ operating software provides the option to create a diagnostics session, → p. 97, § 6.4.

## 6.2 Status messages

- Active errors or warnings are shown flashing in the LC display. Current errors or warnings can be retrieved under “Device status” / “Current events” with error code.
- Detailed information on the status messages is available via the FLOWgate™ operating software in the “Diagnostics” menu via the “Status Diagnostics” tile.

Table 22 Information messages

| Status message | Description/clearance  |
|----------------|--|
| I-1017         | The device firmware has been changed.  |
| I-1018         | The device has been started.   |
| I-1019         | Configuration mode is active. → p. 90, § 5.2.9.1 “Starting and terminating configuration mode” |
| I-1020         | The parameter locking switch is open. → p. 28, § 2.8.1 “Parameter locking switch”              |

Table 23 Warning messages

| Status message | Description/clearance   |
|----------------|---|
| W-2001         | The Event logbook is up to 90% full.<br>The Event logbook can be viewed, stored and reset with the FLOWgate™ operating software.  |
| W-2002         | The Metrology logbook is full.<br>Custody relevant parameters can only be modified after the parameter locking switch has been opened.<br>The Metrology logbook can be reset with the FLOWgate™ operating software.<br>→ p. 93, § 6 “Clearing malfunctions”   |
| W-2003         | More pulses than permissible should be output on the pulse output.<br>Check whether the current flow rate is higher than the maximum flow rate.<br>If the flow rate is within the permissible range, check whether the selected output scaling (= Meter factor) is correct.<br>→ p. 94, § 6.1 “Contacting Customer Service” |
| W-2008         | Flow rate measurement is in status “Warning”.<br>Have the device checked by Customer Service.<br>→ p. 94, § 6.1 “Contacting Customer Service”   |
| W-2009         | The measured flow rate is outside the set warning limits.<br>Check the current measuring conditions or adjust the limits.<br>The warning limits can be set with the FLOWgate™ operating software.   |
| W-2010         | W-2009 = flow rate below warning limit,<br>W-2010 = flow rate above warning limit.  |
| W-2016         | Battery 1 failure.<br>→ p. 103, § 7.3.2 “Changing the battery packs”  |

| Status message | Description/clearance  |
|----------------|--|
| W-2017         | Battery 2 failure.<br><ul style="list-style-type: none"> <li>● With external power supply:<br/>→ p. 102, § 7.2.2 “Changing the backup battery”</li> <li>● For battery operation:<br/>→ p. 103, § 7.3.2 “Changing the battery packs”</li> </ul> |
| W-2018         | External power supply failure.<br>Check the connection and function of the external power supply.<br>→ p. 52, § 3.4.9 “Operation with external power supply”.  |

Table 24 Error messages

| Status message | Description/clearance  |
|----------------|--|
| E-3001         | The Event logbook is full.<br>Check the Event logbook. The Event logbook can be reset with the FLOWgate™ operating software.   |
| E-3006         | Checksum error<br>→ p. 94, § 6.1 “Contacting Customer Service”.  |
| E-3007         | Time invalid<br>→ p. 64, § 4.2 “Commissioning on the display”.   |
| E-3009         | The FLOWSIC500 is in calibration mode.<br>→ p. 91, § 5.2.9.2, “Starting and terminating calibration mode”.   |
| E-3010         | Temperature sensor failure.<br>The FLOWSIC500 uses the default value specified.<br>→ p. 124, § 7.6 “Exchanging an external pressure or temperature sensor”<br>→ p. 94, § 6.1 “Contacting Customer Service”.  |
| E-3012         | Pressure sensor failure.<br>The FLOWSIC500 uses the default value specified.<br>→ p. 124, § 7.6 “Exchanging an external pressure or temperature sensor”<br>→ p. 94, § 6.1 “Contacting Customer Service”.   |
| E-3013         | Device is outside the permissible measurement pressure range.<br>Check Pmin/Pmax vs. pressure.   |
| E-3014         | Flow rate measurement is in status “Malfunction”,<br>→ p. 94, § 6.1 “Contacting Customer Service”.   |
| E-3017         | The K-factor cannot be calculated.<br>Check the values entered for gas composition against the reference conditions and the base conditions.<br>→ p. 80, § 5.2.4 “Main display (with device option volume conversion)”.  |
| E-3018         | Reverse flow<br>The measured creep volume (reverse flow) is larger than the preconfigured buffer volume. → p. 21<br>If larger reverse flows occur regularly, contact Customer Service to have the preconfigured volume adapted.<br>→ p. 94, § 6.1 “Contacting Customer Service”. |
| E-3019         | The measured gas temperature/gas pressure is outside the permissible limits.<br>E-3019 = Gas temperature is below the alarm limit  |
| E-3020         | E-3020 = Gas temperature is above the alarm limit  |
| E-3021         | E-3021 = Gas pressure is below the alarm limit   |
| E-3022         | E-3022 = Gas pressure is above the alarm limit   |
| E-3022         | Check the set alarm limit values.<br>→ p. 88, § 5.2.6.7 “Temperature parameters”   |

### 6.3 Additional messages in the Event logbook

The FLOWSIC500 saves all status messages (→ p. 94, §6.2) as well as further supplementary messages concerning events and status changes in the Event logbook.

Each message code is supplemented with a (+) or (-) to identify an incoming message = (+) or an outgoing message = (-).

Table 25 Information messages in the Event logbook

| Status message | Description/clearance   |
|----------------|---|
| I-1001         | Event logbook has been reset  |
| I-1002         | Parameter logbook has been reset.   |
| I-1003         | Metrology logbook has been reset.   |
| I-1004         | Measuring period archive has been reset.                                    |
| I-1005         | Daily archive has been reset.   |
| I-1006         | Monthly archive has been reset.   |
| I-1010         | Event overview has been reset. *)   |
| I-1011         | Time has been reset. *)   |
| I-1012         | Totalizers have been reset.   |
| I-1013         | Error volume totalizers have been reset. *)                                 |
| I-1014         | All parameters have been reset or a group of parameters have been reset. *) |
| I-1021         | Battery (1) has been replaced.  |
| I-1022         | Battery (2) has been replaced.  |
| I-1023         | Totalizers have been preset. *)   |
| I-1025         | Gas composition logbook reset   |
| I-1026         | Gas parameters changed  |

Table 26 Warning messages in the Event logbook

| Status message | Description/clearance  |
|----------------|--|
| W-2011         | The number of valid measurements (performance of flow rate measurement) is significantly lower than normal. *) |
| W-2012         | Flow rate measurement is performed with reduced precision. *)  |
| W-2013         | Flow rate higher than 120% $Q_{max}$ .   |

Table 27 Error messages in Event logbook

| Status message | Description/clearance   |
|----------------|---|
| E-3002         | Check sum of totalizers is invalid.   |
| E-3003         | Check sum of firmware is invalid.   |
| E-3004         | Parameter is invalid. *)  |
| E-3005         | Check sum of logbooks/archives is invalid. *)   |
| E-3015         | Hardware error in flow rate measurement. *)   |
| E-3016         | Number of valid measurements (performance of flow rate measurement) is not sufficient. *) |

In the Event logbook, additional data, e.g. status, totalizer levels, measured values and parameters at the time of certain events are saved.

These events or messages are identified with \*). The data can be viewed and saved with the FLOWgate™ operating software (→ p. 74, §4.3.5).

## 6.4 Starting a diagnostic session

- 1 Click the  icon in the tool bar to start a diagnostic session.
- 2 Select the desired data collection duration and enter a description.  
It is recommended to select a data collection duration of at least 5 minutes.

Fig. 46 Data collection duration for the diagnostic session



- 3 Click “Start” to start recording.  
The following message with the current storage location of the data collection is shown after successful creation of the diagnostic session.

Fig. 47 Diagnostic recording completed

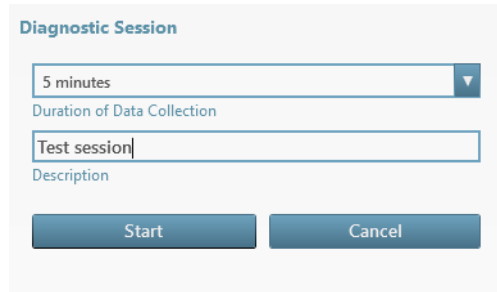

- 4 Click “OK” to confirm the message.
- 5 Store the diagnostic session or send per e-mail.

 The diagnostic sessions are saved as standard as files with the ending .sfgsession under:  
C:\Users\Public\Documents\SICK\FLOWgate  
The name of the storage folder consists of device type and serial number of the device.

Fig. 48 Store the diagnostic session or send per e-mail



- 6 Click “Close” to leave the file at the standard storage location.
  - Click “Save as” to select a different storage location for the diagnostic recording. Selecting the option “Save .zip as” stores the parameter recordings and logbook files as single files in a zip archive.
  - Click “E-mail” to send the file per e-mail. The file is appended to an e-mail when an e-mail client is available. Click “Save as” to select a storage location for the diagnostic recording. Selecting the option “Save .zip as” stores the parameter recordings and logbook files as single files in a zip archive.

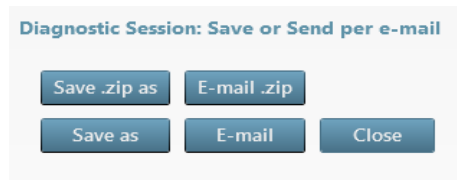

## FLWSIC500

# 7 Maintenance and meter exchange

- Information on handling lithium batteries
- Maintenance when using external power supply
- Maintenance when using battery power supply
- Meter exchange
- Function check of a pressure or temperature sensor
- Exchanging an external pressure or temperature sensor

7.1

**Information on handling lithium batteries**

 **WARNING: Ignition hazard through electrostatic charges**  
 Make sure the electrostatic risks when handling the transportable plastic battery packs are minimized.

- ▶ Take suitable precautionary measures, e.g wear antistatic shoes, when a charge generating mechanism has been identified, e.g. repeated rubbing of battery packs against clothing.
- ▶ Putting the battery packs in the bag or carrying them on a belt, using a keyboard or cleaning with a damp cloth do not cause a significant electrostatic risk.

 **WARNING: Risk of explosion - hazard for intrinsic safety**

- ▶ Only the exchangeable battery packs from SICK with Part No. 2064018 and the backup battery with Part No. 2065928 may be used!
- ▶ Do not use damaged batteries; they must be disposed of correctly!

 **WARNING:**

- ▶ Comply with the national regulations when transporting used battery packs by air freight!

The battery packs are marked with important information concerning storage and disposal.

Table 28

Marking





| Symbol  | Significance                         |
|---|--------------------------------------|
|  | Do not dispose with household trash. |
|  | Recycling                            |

Fig. 49

Identification of battery packs

Backup battery 2R6 cell type: TADIRAN SL-860  
 SICK Part no.: 2065928  
 Serial no.:       
 Date:

**WARNING:** Fire, explosion, and severe burn hazard. Do not recharge, disassemble, heat above 100°C, incinerate or expose contents to water.

**Disposal in EU:** Batteries shall be properly disposed and recycled according to guideline 2006/66/EC. Upon request a disposal service is offered by Tadiran Germany.

**Disposal in US:** Spent batteries shall be treated by an authorized, professional disposal company. It is recommended to contact the local EPA office.

Refer to FLOWSIC500 user manual for further information.

Battery pack 2R20 cell type: TADIRAN SL-2880  
 SICK Part no.: 2064018 Serial no.:  Date:     
**WARNING:** Fire, explosion, and severe burn hazard. Do not recharge, disassemble, heat above 100°C, incinerate or expose contents to water.

**Disposal in EU:** Batteries shall be properly disposed and recycled according to guideline 2006/66/EC. Upon request a disposal service is offered by Tadiran Germany.

**Disposal in US:** Spent batteries shall be treated by an authorized, professional disposal company. It is recommended to contact the local EPA office.

Refer to FLOWSIC500 user manual for further information.

| Variable                        | Description   |
|---------------------------------|---|
| <input type="text" value="00"/> | Serial No.  |
| <input type="text" value="01"/> | Date  |
| <input type="text" value="02"/> | QR-Code → Order No. + <input type="text" value="00"/> |



### 7.1.1 Information on storage and transport

- ▶ Prevent a short circuit of the battery terminals:
  - Store and transport the batteries in their original packaging
  - or tape the battery terminals.
- ▶ Store cool (under 21 °C (70 °F)), dry and without major temperature fluctuations.
- ▶ Protect against permanent sunlight.
- ▶ Do not store near the heating.

### 7.1.2 Disposal information

#### In the EU

- ▶ Dispose of lithium batteries in accordance with the Battery Directive 2006/66/EU.
- ▶ In Germany, you can hand in the batteries at your local recycling center.  
Alternatively, the battery manufacturer Tadiran Germany offers a return service on request.

Contact data:

Phone: +49 (0)6042/954-122

Fax: +49 (0)6042/954-190

[www.tadiranbatteries.de](http://www.tadiranbatteries.de)

#### In the USA

- ▶ Batteries have to be disposed of by an authorized waste disposal company.  
Identification of lithium batteries:
  - Proper shipping name: Waste lithium batteries
  - UN number: 3090
  - Label requirements: MISCELLANEOUS, HAZARDOUS WASTE
  - Disposal code: D003
- ▶ If anything is unclear, contact the local office of the Environmental Protection Agency (EPA).

#### In other countries:

Please observe national regulations for the disposal of lithium batteries.

## 7.2 Maintenance when using external power supply

### 7.2.1 Service life of backup battery

When new, the capacity of the backup battery has been calculated for bridging up to 3 months failure of the supply voltage. When voltage supply is not interrupted, the service life is at least 10 years when stored at approx. 25 °C (77 °F).

Repeated, even short-time voltage failure reduces the remaining buffer capacity of the battery so that exchange is recommended.



If both the supply voltage and the backup battery fail, the clock setting is lost and the FLOWSIC500 does not measure anymore. Totalizer levels determined until then and parameter settings remain permanently stored.

### 7.2.2 Changing the backup battery



**WARNING: Risk of explosion - hazard for intrinsic safety**

► Only the exchangeable battery packs from SICK with Part No. 2064018 and the backup battery with Part No. 2065928 may be used.

- 1 Ensure external voltage supply.
- 2 Open the electronics cover (→ p. 45, §3.4.3)
- 3 Loosen the connection of the backup battery.
- 4 Remove the backup battery.
- 5 Insert a new backup battery and connect the battery to connection BAT2.
- 6 Close the electronics cover (→ p. 45, §3.4.3)
- 7 Confirm battery replacement on the display (→ p. 92, §5.2.13).
- 8 Alternatively, confirm battery replacement with the FLOWgate™ operating software:
  - Connect to device, → p. 67, §4.3.1.
  - Open the tile "System/User" in the "Parameter Modification" area.
  - Start the configuration mode.
  - Click "Battery exchange source 2" in the area "Power supply".
  - Return to the operating mode.



**NOTICE:**

The battery symbol on the display shows full straight away after the battery change.

The check whether the battery is really operational then takes 20 minutes.

### 7.3 Maintenance when using battery power supply

#### 7.3.1 Service life of battery packs

Under typical operating conditions, the expected total service life of both battery packs is 5 years.

The FLOWSIC500 needs more power

- when the display is used frequently,
- when the infrared interface is used,
- when the encoder output is frequently used (scanning cycles < 15 min).

When the electrically isolated NAMUR output (DO\_0) is used, an external voltage supply is recommended due to the significantly higher power requirement.

The capacity of the batteries is reduced in unfavorable climatic conditions, for example when the temperatures are significantly higher or lower than 25 °C (77 ° F).



The complete failure of both battery packs results in the loss of the clock settings and the FLOWSIC500 does not measure anymore. Totalizer levels determined until then as well as the parameter settings remain permanently stored.

#### 7.3.2 Changing the battery packs



**WARNING: Risk of explosion - hazard for intrinsic safety**

- ▶ Only the exchangeable battery packs from SICK with Part No. 2064018 and the backup battery with Part No. 2065928 may be used.

The charge level of the battery packs is shown as a symbol on the display.

Table 29

Battery fill level

| Symbol | Significance                                | Description   |
|--------|---|---|
|        | Battery pack 1 fill level (connection BAT1) | Details on the battery fill level → p. 77, § 5.2.2. |
|        | Battery pack 2 fill level (connection BAT2) |   |

The second battery pack is activated automatically when the first pack is completely empty. When one battery pack is empty, at least this battery pack should be changed. Both battery packs must be changed at the latest when the second battery pack is running low.

- 1 Check on the display which battery pack is empty.
- 2 Open the electronics cover (→ p. 45, § 3.4.3)
- 3 Loosen *only* the respective terminal connection of the empty battery pack.



**NOTICE:**

Only loosen one connection at a time to ensure continuous voltage supply! If both battery packs are to be exchanged at the same time, first replace the empty battery pack and then the still used battery pack.

Fig. 50

Battery connections on the circuit board

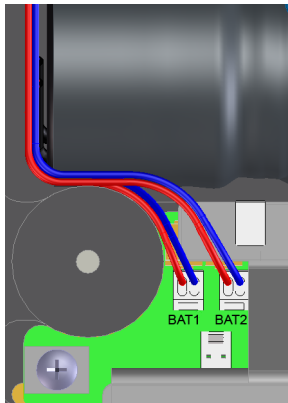

- 4 Remove the battery pack and replace by the new one.
- 5 Reconnect the electrical system.  
The FLOWSIC500 now continues to use the second battery pack and then switches back to the new battery pack.
- 6 Close the electronics cover (→ p. 45, §3.4.3)
- 7 Confirm battery replacement on the display (→ p. 92, §5.2.13).
- 8 Alternatively, confirm battery replacement with the FLOWgate™ operating software:
  - Connect to device, → p. 67, §4.3.1.
  - Login as “Authorized User” on the device.
  - Open the tile “System/User” in the “Parameter Modification” area.
  - Start the configuration mode.
  - When the battery pack on “BAT2” has been exchanged, click “Battery change Source 2” in area “Power supply”.
  - When the battery pack on “BAT1” has been exchanged, click “Battery change Source 1” in area “Power supply”.
- 9 Return to the operating mode.

**NOTICE:**

The battery symbol on the display shows full straight away after the battery change.

The check whether the battery is really operational then takes 20 minutes.

## 7.4 Meter exchange

### 7.4.1 Prerequisites for meter exchange



**NOTICE:**

Ensure that the meter exchange is carried out according to the national regulations for Ex and pressure applications of your country.

### 7.4.2 Hazards during meter exchange



**WARNING: Hazards due to combustible gases or high pressure**

Natural gas under line pressure flows through the gas flow meter during running operation. The gas flow meter may only be exchanged when the equipment is at a standstill.

*Before commencing installation work:*

- ▶ Ensure the pipeline is free from pressure and free from combustible gases.
- ▶ Purge the pipeline with inert gas if necessary.
- ▶ Observe the safety information in §1.1 (→ p. 10) and §3.1 (→ p. 36).



**NOTICE:**

The gas flow meter may only be exchanged by skilled persons who, based on their technical training and knowledge in pipeline construction as well as knowledge of the relevant regulations, can assess the tasks given and recognize the hazards involved.

- ▶ Observe the information in §1.4 (→ p. 13).
- ▶ In case of doubt, please contact the local SICK Customer Service.

### 7.4.3 Sequence of meter exchange

To exchange the gas flow meter, proceed as follows:

- 1 Download the user-specific configuration of the installed gas flow meter (→ p. 108, § 7.4.6).
- 2 Disconnecting electrical connections (→ p. 109, § 7.4.7).
- 3 Removing the installed gas flow meter (→ p. 110, § 7.4.8).
- 4 Installing the replacement gas flow meter (→ p. 114, § 7.4.9).
- 5 Perform a leak tightness check (→ p. 116, § 7.4.10).
- 6 Connect the new gas flow meter to the electric system (→ p. 43, § 3.4).
- 7 Upload the user-specific configuration of the previously installed gas flow meter to the new gas flow meter (→ p. 119, § 7.4.11).
- 8 Check the function of the gas flow meter (→ p. 123, § 7.4.12).
- 9 If necessary, secure metrologically (→ p. 123, § 7.4.13).

#### 7.4.4 Required tools and auxiliary material

- Meter exchange set (item numbers → p. 130, §8.2.1 ) with:
  - Test cap for the respective meter size (→ Fig. 51, component no. 9)
  - Socket wrench
  - Allen key

Table 30 Openings

| Meter size | Socket wrench | Allen key |
|------------|---------------|-----------|
| DN50/2"    | 19            | 8         |
| DN80/3"    | 24            | 10        |
| DN100/4"   | 30            | 14        |
| DN150/6"   |               |           |

- Torque wrench
- Transport protection for the gas flow meter with a safety strap (item numbers → p. 129, §8.1.3)
- Silicone grease
- Leak detection spray
- Lubricant, metal-free or suitable for aluminum, e.g. OKS 235, to prevent thread mountings seizing up.



**NOTICE:**

Do not use copper paste!

7.4.5

**Overview**

Fig. 51

Components for meter exchange using DN50/2" as example

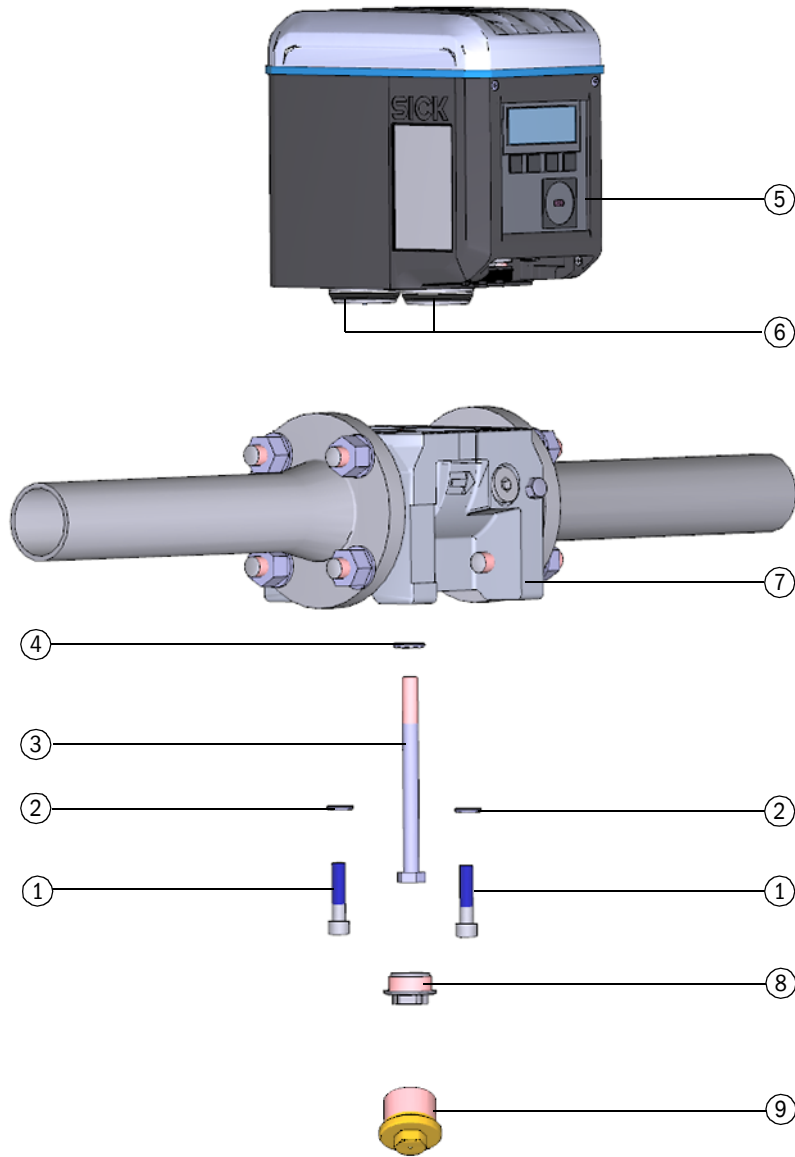

- |   |                  |   |                              |
|---|------------------|---|------------------------------|
| 1 | Securing screws  | 6 | Connecting pieces with seals |
| 2 | Ripplock washers | 7 | Adapter                      |
| 3 | Center bolt      | 8 | Locking cap                  |
| 4 | Ripplock washer  | 9 | Test cap                     |
| 5 | Gas flow meter   |   |                              |

Subject to change without notice

### 7.4.6 Backup of user-specific configuration of installed gas flow meter

- 1 Connect to device, → p. 67, §4.3.1.
- 2 Open the “Meter Replacement” tile in the “Service” menu.
- 3 Click “Backup Parameter” to backup the parameters of the currently installed gas flow meter.

Fig. 52

Parameter backup

| Register Name      | Value in Device | Value from Source | Unit |
|--------------------|-----------------|-------------------|------|
| Firmware_CRC       | 0x1C03          |                   |      |
| Parameter_CRC_User | 0xF2DB          |                   |      |

- 4 Save the parameter file:
  - Click “Save as” to choose a storage location for the parameter file.
  - Click “E-mail” to send the file per e-mail. The file is appended to an e-mail when an e-mail client is available.

Fig. 53

Save the parameter file

- 5 Click “Close” after storing the csv file.

**NOTICE:**

The parameter set is required after exchanging the gas flow meter to transfer the customer-specific or device-specific parameters to the new gas flow meter.



7.4.7

**Disconnecting electrical connections**

Observe the safety information in §3.4 (→ p. 43)!

Depending on the configuration of your FLOWSIC500, proceed as follows:

- 1 Disconnect the potential equalization line at the outer ground terminal (on the right of the M12 plug-in connections) of the electronic housing (→ Fig. 19, p. 47).
- 2 If installed, remove the plug-in connector cover. To do so, loosen the capstan screws (→ Fig. 30, p. 55).
- 3 If installed, manually loosen and remove the M12 plug-in connectors for external power supply and the signal output (→ Fig. 19, p. 47).
- 4 If installed, manually loosen and remove the plug-in connectors of the pressure and temperature sensors (→ Fig. 19, p. 47).
- 5 Open the electronics cover (→ p. 45, §3.4.3).
  - ▶ Configuration with external power supply and backup battery:  
Switch the backup battery to “N.c.”.

Fig. 54

Switching the backup battery

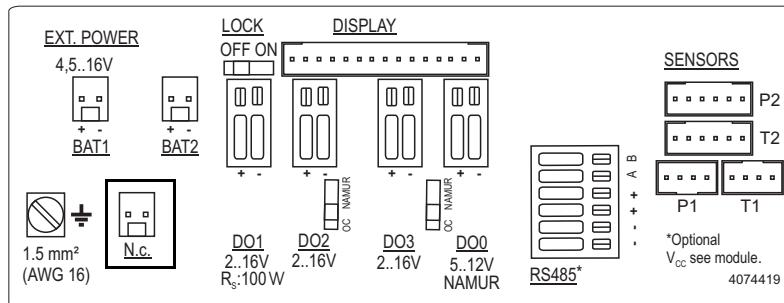

- ▶ Self-sufficient power configuration with battery packs:  
Remove the battery packs and dispose of or store properly according to → p. 100, §7.1.

SICK recommends inserting new batteries during every meter exchange.

- 6 Close the electronics cover again (→ p. 45, §3.4.3).

## 7.4.8

**Removing the installed gas flow meter**

1 Ensure safe conditions.

**WARNING: Hazards due to combustible gases or high pressure**

Natural gas under line pressure flows through the gas flow meter during running operation. The gas flow meter may only be exchanged when the equipment is at a standstill.

*Before commencing installation work:*

- ▶ Ensure the pipeline is free from pressure and free from combustible gases.
- ▶ Purge the pipeline with inert gas if necessary.
- ▶ Observe the safety information in §1.1 and §3.1.

**WARNING: Hazard due to the gas flow meter falling down**

- ▶ Secure the gas flow meter before loosening the screw fitting, e.g. by supporting the gas flow meter or with the help of another person holding the gas flow meter.

2 Unscrew the closure cap.

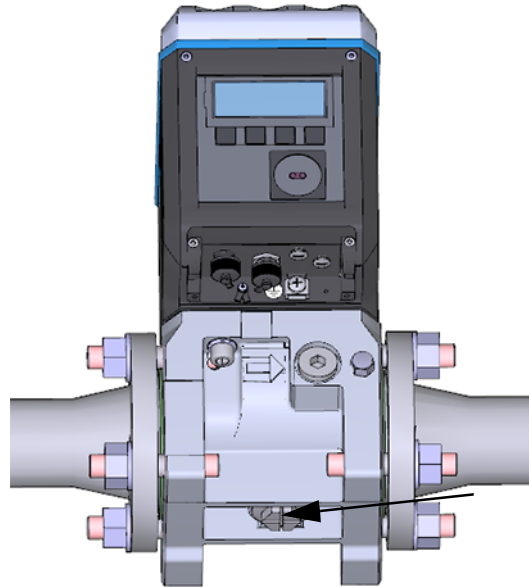

3 Remove securing screws (1) with the Allen key

| Meter size | Number of securing screws |
|------------|---------------------------|
| DN50/2"    | 2                         |
| DN80/3"    | 3                         |
| DN100/4"   | 4                         |
| DN150/6"   | 4                         |

4 Loosen center bolt (2) five to six turns.

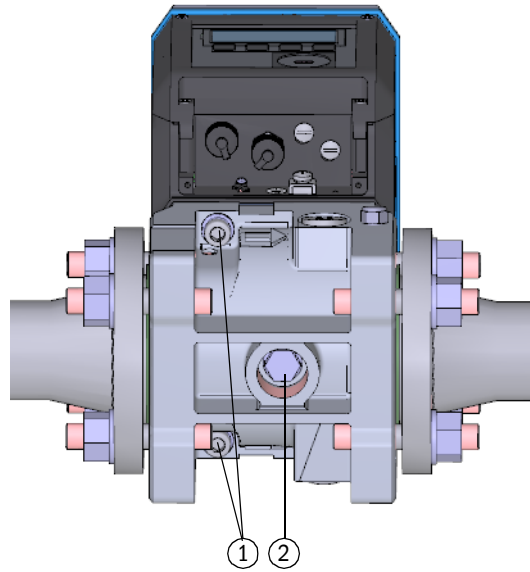

5 Instead of the closure cap, at first manually screw the test cap for the respective meter size in until the test cap touches the center bolt.

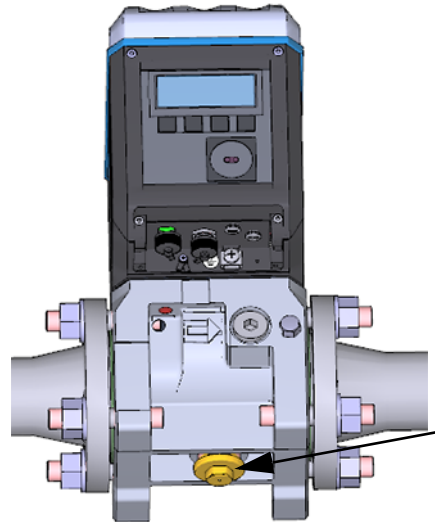

6 Keep on screwing the test cap in with the socket wrench against the resistance of the center bolt until the test cap is completely screwed in. The center bolt pushes the seals upwards and lifts the gas flow meter up.

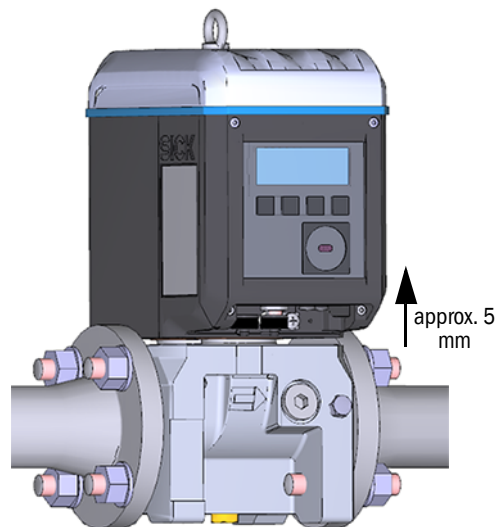

- 7** Unscrew the test cap and the center bolt completely with the socket wrench.

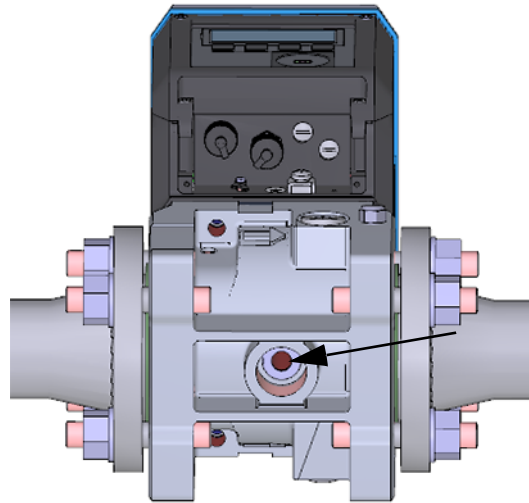

- 8** Pull the gas flow meter straight upwards and remove it.  
**9** Ensure that the connecting pieces with the O-rings are still on the gas flow meter.

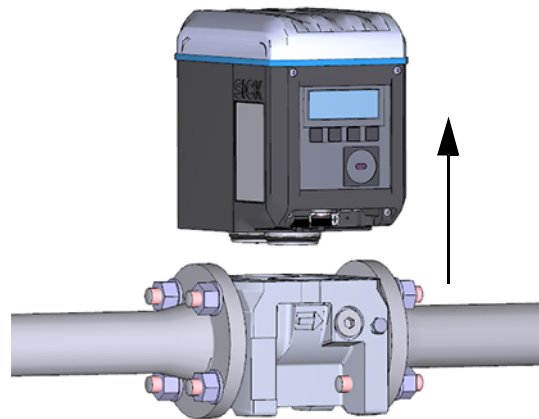

- 10** Ensure that the gas flow meter can not be contaminated or damaged at any time.  
**11** Secure the removed gas flow meter with the transport protection before shipping:
- Fit the gas flow meter on the transport protection.
  - Secure the gas flow meter with the strap provided.

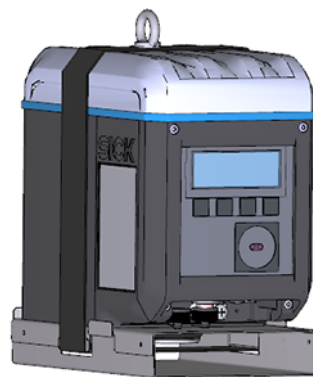

**12** Check the sealing surfaces on the adapter (marked green):

- When the sealing surfaces are contaminated, clean carefully.
- Ensure that the sealing surfaces are undamaged. They have to be free of scratches or grooves.

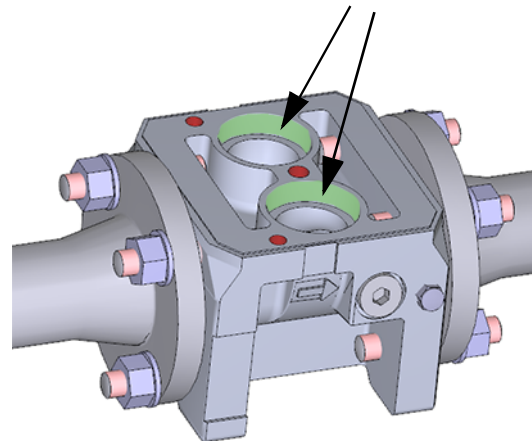

**WARNING: Hazard of leaks**

There is a risk of the installation becoming leaky when the sealing surfaces of the adapter are damaged. Operation in leaky condition is not allowed and potentially dangerous.

- ▶ In this case, the adapter has to be exchanged.
- ▶ Please contact your local SICK Customer Service.

## 7.4.9

**Installing the replacement gas flow meter****NOTICE:**

When the sealing surfaces of the adapter have been cleaned with a detergent, let it evaporate completely.

- 1 Carefully remove the transport protection of the new gas flow meter. Pay attention to the arrangement of O-ring seals (1) and support plates (2).

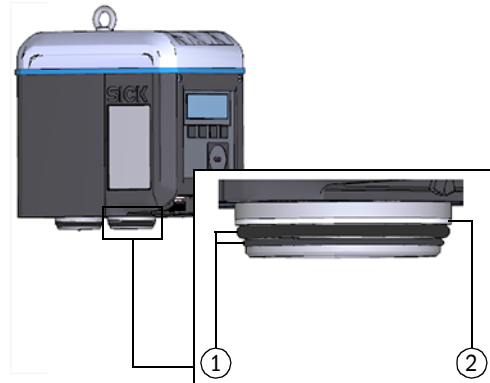

- 2 Check the outside of the replacement gas flow meter for transport damage. Only undamaged gas flow meters may be installed.
- 3 Ensure that flat sealing (1) and the O-rings on connection pieces (2) are not damaged.
- 4 Check all threads on the components for damage.

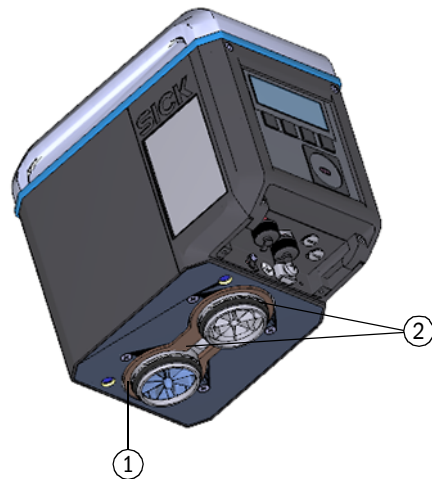

- 5 Apply silicone grease to the sealing surfaces of the adapter.
- 6 Apply silicone grease to the O-rings on the connection pieces.

- 7 Carefully fit the gas flow meter on the adapter. Pay attention to the correct orientation of the gas flow meter. The position of the center bolt allows only one fitting direction.

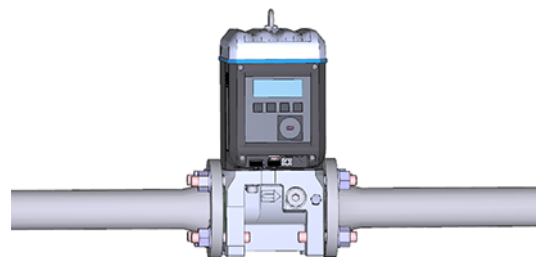

- 8** Carefully plug the connection pieces with the O-rings into the openings of the adapter.

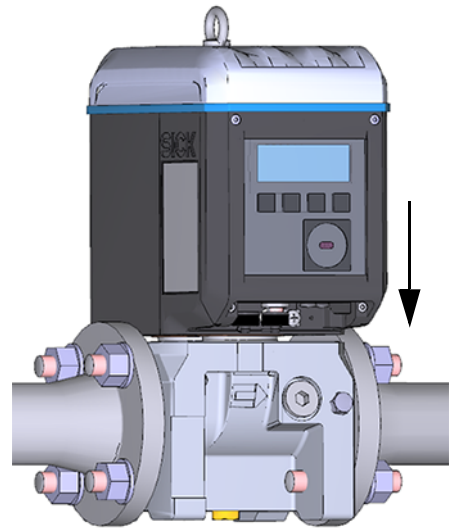

- 9** First screw the provided new center bolt with Ripplock washer in manually.  
SICK recommends using lubricant.
- 10** Then tighten the center bolt with the socket wrench to the specified tightening torque.

| Meter size | Tightening torque |            |
|------------|-------------------|------------|
| DN50/2"    | 45 Nm             | 34 lbf ft  |
| DN80/3"    | 100 Nm            | 74 lbf ft  |
| DN100/4"   | 145 Nm            | 107 lbf ft |
| DN150/6"   |                   |            |

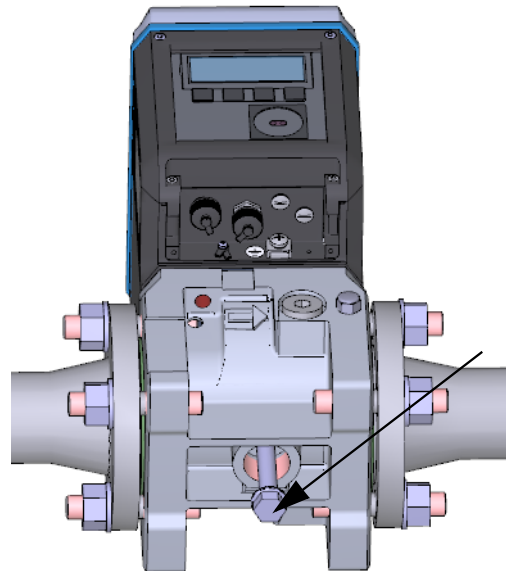

- 11** First screw the provided securing screws with Ripplock washers in manually.
- 12** Then tighten the securing screws with the Allen key to the specified tightening torque.

| Meter size | Tightening torque |           |
|------------|-------------------|-----------|
| DN50/2"    | 20 Nm             | 15 lbf ft |
| DN80/3"    | 45 Nm             | 34 lbf ft |
| DN100/4"   | 100 Nm            | 74 lbf ft |
| DN150/6"   |                   |           |

- 13** Check the leak tightness, → p. 116, §7.4.10.

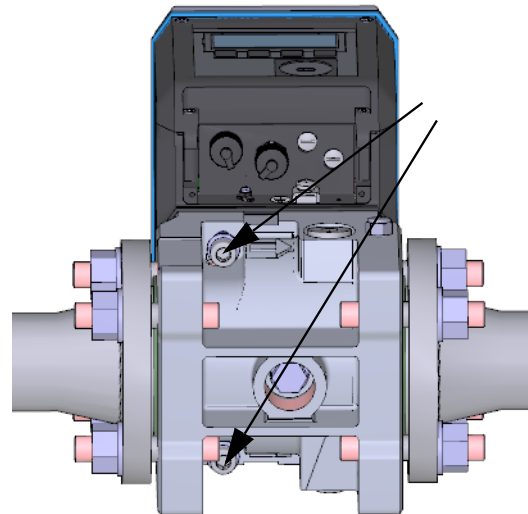

Subject to change without notice

- |    |  |
|----|--|
| 14 | After a successful leak tightness check, connect the replacement gas flow meter to the electric system, see §3. 4 “Electrical installation”. |
| 15 | If desired, upload the configuration of the previously installed gas flow meter to the replacement gas flow meter (→ p. 108, §7.4.6).        |
| 16 | Checking the function of the new gas flow meter, → p. 123, §7.4.12.  |
| 17 | If necessary, secure metrologically (→ p. 123, §7.4.13).   |

## 7.4.10

**Perform a leak tightness check**

After each exchange of the gas flow meter, the correct installation of the gas flow meter and the leak tightness of the measuring device has to be checked.

To check the leak tightness, the corresponding test cap for the respective meter size is needed (→ p. 106, §7.4.4).

- 1 First screw the test cap for the respective meter size in manually.
- 2 Then tighten the test cap with the socket wrench until the test cap is completely screwed in.

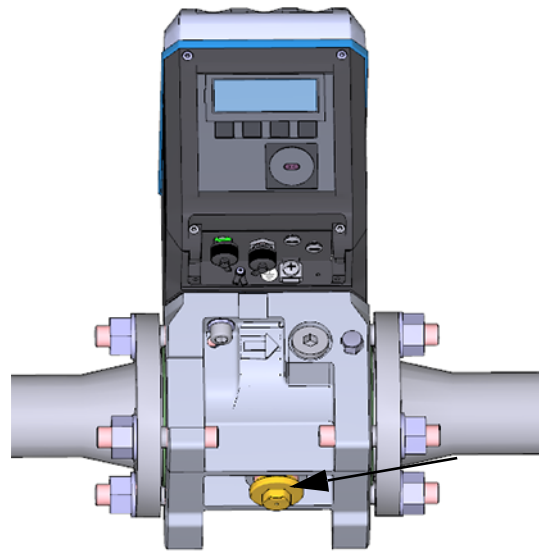

- 3 Slowly increase the pressure in the device (max. gradient 3 bar/min or 45 psi/min) up to the line pressure.
- 4 Apply leak detection spray to the opening of the test cap.
- 5 Check over at least 15 min whether gas escapes at the opening of the test cap
  - When no gas escapes from the opening of the test cap, see → p. 117, §7.4.10.1.
  - When gas escapes from the opening of the test cap, see → p. 117, §7.4.10.2.



7.4.10.1 **Leak tightness check successful**

- 1 Remove the test cap with the socket wrench.
- 2 Screw in the closure cap.
- 3 Then connect the replacement gas flow meter to the electric system, see §3. 4 “Electrical installation”.

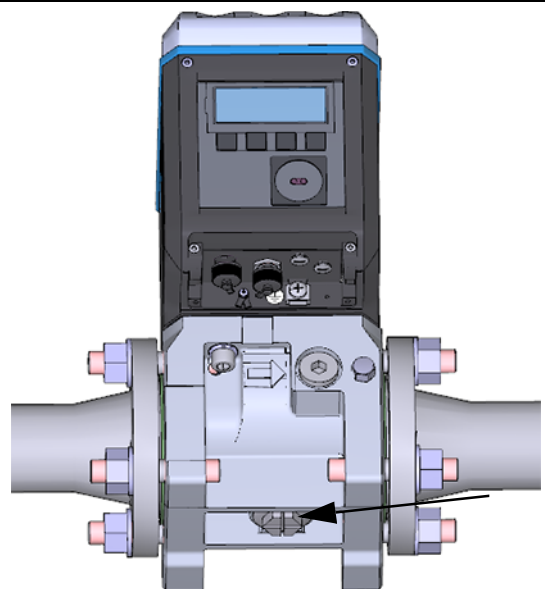

7.4.10.2 **Leak tightness check not successful**

- 1 Close the line and depressurize the device.
- 2 Vent the environment.
- 3 Remove the gas flow meter from the adapter as described, see → p. 110, § 7.4.8.

4 Check flat seal (1) and the O-rings on connections pieces (2) for completeness, intactness and correct installation. When the sealing elements are damaged, a new seal set is available as spare part.

| Meter size | Item number |
|------------|-------------|
| DN50       | 2067394     |
| DN80       | 2067395     |
| DN100      | 2067396     |
| DN150      |             |

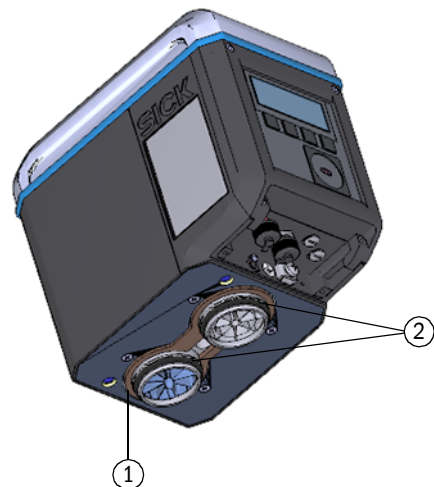

- 5 Check the sealing surfaces on the adapter (marked green) for contamination and damage.
- 6 When the sealing surfaces are damaged, e.g. due to corrosion or external force, the adapter has to be exchanged.

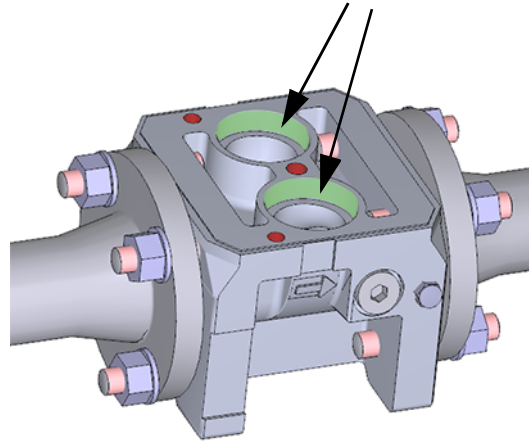

- 7 When the adapter is damaged, it has to be removed and a new adapter installed → p. 37, §3.3.  
Then install the gas flow meter anew, → p. 114, §7.4.9.
- 8 When the components do not seem to be damaged but leak tightness can not be established, please contact SICK Customer Service (→ p. 94, §6.1).

## 7.4.11 Loading the parameter backup

**NOTICE: Parameter protection**

- ▶ Check the position of the parameter locking switch, see → p. 77, §5.2.1.
- ▶ When open, proceed with step 1.
- ▶ When closed, the counter values and the configuration of the digital outputs cannot be written to the meter.

An information message is output when the parameters are being written. If the further parameters are however to be written, click “OK” to confirm the information message

- 1 Connect to device, → p. 67, §4.3.1.
- 2 Open the “Meter Replacement” tile in the “Service” menu.
- 3 Set the source for the parameter exchange to “Parameter file”.
- 4 Select the parameter file stored before exchanging the meter, → p. 108, §7.4.6.

Fig. 55

## Parameter file

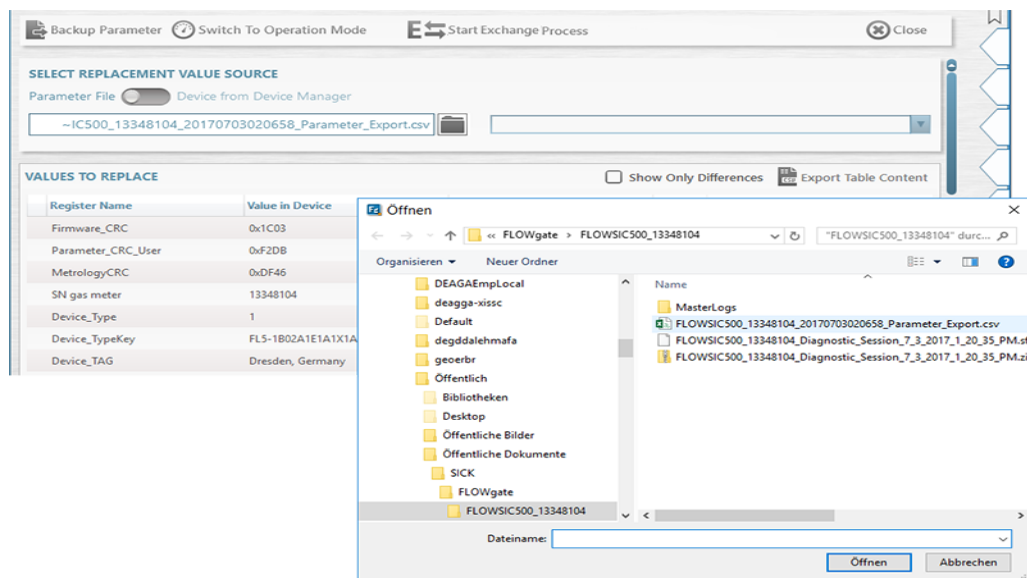

- 5 An overview of the old and new values is shown under “Values to replace”. Activate the “Show only differences” checkbox to show only the differences.
- 6 Activate Configuration mode.
- 7 Click “Start Value Exchange” to load the parameter backup.

Fig. 56

## Starting the exchange



- 8 In the dialog that opens, select whether the counter readings are to be used from the saved parameter set or should be reset. The operating company is responsible for deciding whether to accept or reset the volume counters.

Fig. 57

## Counter values

- 9 Confirm with "OK".
- 10 The serial numbers of the pressure and temperature sensor are queried for gas flow meters with external pressure and temperature technology.

Fig. 58

## Serial numbers for pressure and temperature sensors

- 11 Check the serial numbers.
- 12 Enter the new serial numbers when the numbers do not match the serial numbers of the installed pressure and temperature sensors.
- 13 Confirm with "OK".
- 14 Check the serial number of the adapter; enter the serial number when different from the one stored.

Fig. 59

## Adapter serial number

- 15 During transfer of the parameter values, the sequence is shown in a progress bar.
- 16 Confirm the upload with "OK" after completion of the upload.  
The "Meter exchange report" is created.

17 Save the report as pdf file or csv file or send by e-mail.

Fig. 60

Saving the meter exchange report

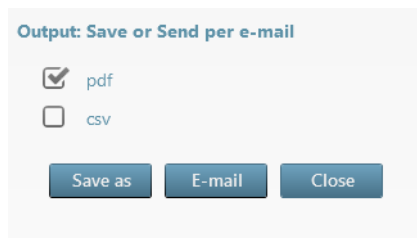



Fig. 61

## Meter exchange report (example)

| FLOWSIC500            |                                | Meter Replacement Report<br>ID 10101000000 |                      |  |  |
|-----------------------|--------------------------------|--|----------------------|---|--|
| Device name           | Dresden, Germany               | Device Type                                | Ultrasonic gas meter |   |  |
| Station / Description |                                | Manufacturer                               | SICK                 |   |  |
| SN gas meter          | 13348104                       | Nominal Diameter                           | DN50   2"            |   |  |
| Device Type Key       | FL5-1B02A1E1A1X1A1C2D3B1C1L2XX | Firmware Version                           | 2.07.00              |   |  |
| Company               |                                | Firmware CRC                               | 0x1C03               |   |  |
| Address               |                                | Metrology CRC                              | 0xDF46               |   |  |
| ZIP Code, City        |                                | Adjust Parameter CRC                       | 0xF2CD               |   |  |
| Country               |                                | Created with                               | FLOWgate 1.6.0.4604  |   |  |
| GPS                   | Lat: 0.00000   Lon: 0.00000    |  |                      |   |  |

|                    | Replaced meter                 | New meter                      |
|--------------------|--------------------------------|--------------------------------|
| SN gas meter       | 13348104                       | 13348104                       |
| Device Type Key    | FL5-1B02A1E1A1X1A1C2D3B1C1L2XX | FL5-1B02A1E1A1X1A1C2D3B1C1L2XX |
| Parameter CRC User | 0xF2DB                         | 0xF2DB                         |
| Metrology CRC      | 0xDF46                         | 0xDF46                         |
| Firmware CRC       | 0x1C03                         | 0x1C03                         |

| Register              | Initial value in device | New value        | Unit | Transfer state | Remark                |
|-----------------------|-------------------------|------------------|------|----------------|-----------------------|
| Device_TAG            | Dresden, Germany        | Dresden, Germany |      | no Transfer    | kept (no differences) |
| Serial number adapter | 00003320                | 123              |      | Success        |                       |
| Service_TimeOut       | 15                      | 15               | min  | no Transfer    | kept (no differences) |
| UserEnable            | 7                       | 7                |      | no Transfer    | kept (no differences) |
| Pwd_User_1            | ****                    | ****             |      | no Transfer    | kept (no differences) |
| Pwd_User_2            | ****                    | ****             |      | no Transfer    | kept (no differences) |
| Pwd_User_3            | ****                    | ****             |      | no Transfer    | kept (no differences) |
| Pwd_AuthorizedUser_1  | ****                    | ****             |      | no Transfer    | kept (no differences) |
| Pwd_AuthorizedUser_2  | ****                    | ****             |      | no Transfer    | kept (no differences) |
| Pwd_AuthorizedUser_3  | ****                    | ****             |      | no Transfer    | kept (no differences) |
| DO.0_Configuration    | 0                       | 0                |      | no Transfer    | kept (no differences) |
| DO.1_Configuration    | 2                       | 2                |      | no Transfer    | kept (no differences) |
| DO.2_Configuration    | 5                       | 5                |      | no Transfer    | kept (no differences) |
| DO.3_Configuration    | 8                       | 8                |      | no Transfer    | kept (no differences) |
| PulseSource           | 1                       | 1                |      | no Transfer    | kept (no differences) |
| PulseSource2          | 0                       | 0                |      | no Transfer    | kept (no differences) |
| PulseFrequencyLimit   | 400                     | 400              | Hz   | no Transfer    | kept (no differences) |
| PulseFrequencyLimit2  | 10                      | 10               | Hz   | no Transfer    | kept (no differences) |

Data date: 7/3/2017 2:38:02 PM



Print date: 7/3/2017 2:38:02 PM

Page 1 of 4

Subject to change without notice

#### 7.4.12 **Checking the function of the new gas flow meter**

- ▶ Check on the display if there are any malfunctions or warnings:

|   |                            |  |
|---|----------------------------|--|
|  | Device status: Malfunction | The device has an error, the measured value is invalid.      |
|  | Device status: Warning     | The device has a warning, the measured value is still valid. |

- ▶ When malfunctions or warnings exist, clear the cause (→ p. 93, §6).
- ▶ Alternatively, check the device status with the FLOWgate™ operating software, → p. 74, §4.3.5.
- ▶ Create a diagnostics session and file with the device documentation, → p. 97, §6.4 .

#### 7.4.13 **Securing metrologically**

- ▶ Gas flow meter and adapter can be secured at the joint by a user seal (adhesive label) (→ p. 31, §2.9).
- ▶ When the parameter locking switch has been opened during the meter exchange, secure the parameter locking switch anew metrologically (→ Fig. 10, p. 32).

## 7.5 Function check of a pressure or temperature sensor

The error status of a sensor is displayed on the device as an event.

- 1 Switch to main display “Current events”.
- 2 Check the list for a current event with type 'E-3010' (temperature sensor failure) or 'E-3012' (pressure sensor failure).

Exchange the sensor involved when one of these errors is displayed → p. 124, §7.6.



Replace the gas flow meter in the device configuration with internal pressure and temperature sensors.

If an error is not displayed, the sensor function can be checked by comparing the measured value on the FLOWSIC500 with the measured value of a reference sensor.

## 7.6 Exchanging an external pressure or temperature sensor



### **WARNING: Hazard through wrong spare parts**

The FLOWSIC500 and the delivered pressure and temperature sensors are designed intrinsically safe.

- ▶ Only pressure and temperature sensors from SICK may be used → p. 130, §8.2.2.
- ▶ The pressure and temperature sensors can be connected and disconnected in the hazardous area as well.
- ▶ The pressure and temperature sensors may only be connected using the M8 plug-in connectors marked accordingly on the FLOWSIC500.
- ▶ Modifying the electrical connection parts is not allowed.



### **NOTICE:**

The pressure and temperature sensors can only be replaced when the parameter locking switch is open..

### 7.6.1 Exchanging the pressure sensor

- 1 Three-way test valve: Move the lever to the test position (→ Table 17).  
Kamstrup test valve: Fit the adapter on the test connection (Part No. 2071841).
- 2 Unscrew the sensor from the three-way test valve.  
Here, loosen the screw fitting slowly so that any overpressure can escape under control.
- 3 Loosen the plug-in connector cover.
- 4 Disconnect the plug.
- 5 Connect the plug to the M8 connection on the FLOWSIC500.
- 6 Screw the plug-in connector cover tight.
- 7 Install a new pressure sensor on the pressure measuring port marked “P<sub>m</sub>” → p. 56, §3.5.2.
- 8 Enter the serial number of the new sensor in the FLOWSIC500 with the FLOWgate™ operating software.
  - Connect to device, → p. 67, §4.3.1.
  - Open the “Device Identification” tile in the “Parameter Modification” menu.
  - Start the configuration mode.
  - Enter the new serial number in the field “Pressure sensor serial number”.
  - Return to the operating mode. The new serial number is written to the device.



- 9 Check the function by comparing the operating point or checking the display value (remove adapter on test connection) against a reference measurement.

**NOTICE: Leak tightness check**

SICK recommends a leak tightness check after sensor replacement.

## 7.6.2

**Exchanging the temperature sensor**

The temperature sensor can be greased with heat-conductive oil or paste to improve its performance.

- 1 Loosen the locknut and pull the temperature sensor out of the protective tube.
- 2 Loosen the plug-in connector cover.
- 3 Disconnect the plug.
- 4 Guide the plug of the new sensor through the plug-in connector cover.
- 5 Connect the plug to the M8 connection on the FLOWSIC500.
- 6 Screw the plug-in connector cover tight.
- 7 Fit the new temperature sensor in the protective tube → p. 60, §3.5.3.
- 8 Enter the serial number of the new sensor in the FLOWSIC500 with the FLOWgate™ operating software:
  - Connect to device, → p. 67, §4.3.1.
  - Open the “Device Identification” tile in the “Parameter Modification” menu.
  - Start the configuration mode.
  - Enter the new serial number in the field “Temperature sensor serial number”.
  - Return to the operating mode. The new serial number is written to the device.
- 9 Check the function by comparing the operating point or checking the display value (remove adapter on test connection) against a reference measurement.



# FLWSIC500

## 8 Accessories and spare parts

Accessories

Spare parts

8.1 **Accessories**8.1.1 **Gas flow meter accessories**

| Description  | Part No. |
|--|----------|
| Mounting set for meter installation 2" /DN50 with flange type ANSI150 (ASME B16.5)   | 2067402  |
| Mounting set for meter installation 3" /DN80 with flange type ANSI150 (ASME B16.5)   | 2067403  |
| Mounting set for meter installation 4" /DN100 with flange type ANSI150 (ASME B16.5)  | 2067404  |
| Mounting set for meter installation 6" /DN150 with flange type ANSI150 (ASME B16.5)  | 2067405  |
| Mounting set for meter installation 2" /DN50 with flange type PN16 (EN1092-1)  | 2067406  |
| Mounting set for meter installation 3" /DN80 with flange type PN16 (EN1092-1)  | 2067407  |
| Mounting set for meter installation 4" /DN100 with flange type PN16 (EN1092-1)   | 2067408  |
| Mounting set for meter installation 6" /DN150 with flange type PN16 (EN1092-1)   | 2067409  |
| Dummy plug for pressure connection NPT 1/4"  | 2067398  |
| Dummy plug for temperature connection G1/2"  | 2067401  |
| M12 plug (A-coded) for data transfer   | 2067419  |
| M12 connector (B-coded) for power supply   | 2067420  |
| 2 m connection cable for data transfer; -25 °C ... +60 °C / -13 °F ... +140 °F; with connector (A-coded) and ferrules  | 2067422  |
| 5 m connection cable for data transfer; -25 °C ... +60 °C / -13 °F ... +140 °F; with connector (A-coded) and ferrules  | 2067423  |
| 2 m connection cable for data transfer; -40 °C ... +70 °C / -40 °F ... +158 °F; with connector (A-coded) and ferrules  | 2067630  |
| 5 m connection cable for data transfer; -40 °C ... +70 °C / -40 °F ... +158 °F; with connector (A-coded) and ferrules  | 2067631  |
| 10 m connection cable for power supply; -25 °C ... +60 °C / -13 °F ... +140 °F; with connector (B-coded) and ferrules  | 2067424  |
| 20 m connection cable for power supply; -25 °C ... +60 °C / -13 °F ... +140 °F; with connector (B-coded) and ferrules  | 2067425  |
| 10 m connection cable for power supply; -40 °C ... +70 °C / -40 °F ... +158 °F; with connector (B-coded) and ferrules  | 2067632  |
| 20 m connection cable for electrical supply; -40 °C ... +70 °C / -40 °F ... +158 °F; with plug (B-coded) and connector sleeves   | 2067633  |
| Intrinsically safe power supply JBZ-02; input voltage 10.5... 15V, nominal 12V; ATEX II(2)G [EX ib] IIC; DIN rail mounting; degree of protection IP20; operating temperature: -25°C... +60°C   | 6050601  |
| Single-channel safety barrier series 9001; operating voltage 12 V DC; ATEX II 3 (1) G Ex nA [ia Ga] IIC/IIB T4 Gc; CSA Class I, Division 2, Groups A, B, C, D; degree of protection IP20/40; operating temperature -20 °C ... +60 °C | 6050603  |
| Power supply unit 253 V AC / 12 V DC; operating voltage 12 V DC/1 A; 1-phase; screw connection; DIN rail mounting NS 35, EN 60715; CUL listed; degree of protection IP20; operating temperature: -25 °C ... 70 °C                    | 6050642  |
| Infrared/USB adapter HIE-04; data transfer up to 38400 baud; USB 2.0; cable length 2.25 m; ATEX II 2G Ex mb IIC T4; operating temperature -25 °C ... +60 °C; degree of protection IP30   | 6050602  |
| Tamper-proof protection of connectors  | 2067397  |
| Elgas midiDatcom: Battery-operated data logger with integrated GSM/GPRS modem; ATEX II 1G Ex ia IIA T3 Ga; battery service life > 5 yearse   | 6058324  |
| Display protector for FLOWSIC500, retrofittable  | 2085547  |

8.1.2 **Volume conversion (device option) accessories**

| Description   | Part No. |
|---|----------|
| Pressure connection set, -40 °C to 70 °C: Three-way cock, fitting with ferrule 6 mm, test connection (Minimess coupling)                                    | 2066281  |
| Pressure connection set, -40°C to 70°C: Three-way cock, fitting with ferrule 1/4", test connection (Minimess coupling)                                      | 2071770  |
| Pressure connection set, -25°C to 60°C: Kamstrup test valve BDA04 (G1/4"), fitting with ferrule   | 2071098  |
| Hose connection set DN4 RP1/4   | 2071841  |
| Temperature bag for nominal widths DN50 to DN100   2" to 4"<br>Seal for use in -40°C to 70°C  | 2068309  |
| Temperature bag for nominal width DN150   6"<br>Seal for use in -40°C to 70°C   | 2093697  |
| Temperature bag for nominal widths DN50 to DN100   2" to 4"<br>Seal for use in -40°C to 70°C<br>Incl. leak tightness/strength test according to DIN 30690-1 | 2095155  |
| Temperature bag for nominal width DN150   6"<br>Seal for use in -40°C to 70°C<br>Incl. leak tightness/strength test according to DIN 30690-1                | 2095156  |

8.1.3 **Transport accessories**

| Description   | Part No. |
|---|----------|
| Transport protection for gas flow meter, rated width DN50/2"  | 2079021  |
| Transport protection for gas flow meter, rated width DN80/3"  | 2079001  |
| Transport protection for gas flow meter, rated width DN100/4" | 2079022  |
| Transport protection for gas flow meter, rated width DN150/6" |          |

## 8.2 Spare parts

### 8.2.1 Gas flow meter spare parts

| Description   | Part No. |
|---|----------|
| Battery (7.2 V; 19 Ah) for self-sufficient meter operation                            | 2064018  |
| Backup battery (7.2 V; 2.7 Ah) for intrinsically safe main power supply               | 2065928  |
| Display module for FLOWSIC500; for output configuration "A-E" (type code)             | 2066077  |
| Display module for FLOWSIC500; for output configuration "F-L" (type code)             | 2092947  |
| Display seal  | 2095177  |
| RS485 module; rated input voltage 4 - 16 V; for output configuration "J" (type code)  | 2087946  |
| RS485 module; rated input voltage 2.7 - 5 V; for output configuration "I" (type code) | 2087945  |
| Tool set for gas flow meter exchange 2" /DN50   | 2067510  |
| Tool set for gas flow meter exchange 3" /DN80   | 2067511  |
| Tool set for gas flow meter exchange 4" /DN100 and 6" /DN150                          | 2067512  |
| Gasket set for gas flow meter exchange 2" /DN50                                       | 2067394  |
| Gasket set for gas flow meter exchange 3" /DN80                                       | 2067395  |
| Gasket set for gas flow meter exchange 4" /DN100 and 6" /DN150                        | 2067396  |

### 8.2.2 Volume conversion (device option) spare parts

| Description   | Part No. |
|---|----------|
| EDT23 - digital pressure sensor; overpressure 0 to 4 bar; G1/4" male thread     | 2071175  |
| EDT23 - digital pressure sensor; overpressure 0 to 10 bar; G1/4" male thread    | 2071174  |
| EDT23 - digital pressure sensor; overpressure 0 to 20 bar; G1/4" male thread    | 2071176  |
| EDT23 - digital pressure sensor; overpressure 0,8 to 5,2 bar; G1/4" male thread | 2071178  |
| EDT23 - digital pressure sensor; overpressure 2 to 10 bar; G1/4" male thread    | 2071179  |
| EDT23 - digital pressure sensor; overpressure 4 to 20 bar; G1/4" male thread    | 2071180  |
| EDT34 - digital temperature sensor, -25 °C to +60 °C                            | 2071181  |
| EDT34 - digital temperature sensor, -40 °C to +70 °C                            | 2071777  |
| Sealing plug NPT 1/4"   | 2067398  |
| Sealing plug G1/4"  | 2067400  |
| Pipe screw fitting for pipe diameter 6 mm                                       | 2071771  |
| Pipe screw fitting for pipe diameter 1/4"                                       | 2069071  |
| Adapter from NPT 1/4" male thread to G1/4" female thread                        | 2075562  |

# FLWSIC500

## 9 Annex

- Conformities and Technical Data
  - Dimensional drawings
  - Type plates
  - Type code
- Internal terminal assignment
- Installation examples

## 9.1 Conformities and Technical Data

### 9.1.1 CE certificate

The FLOWSIC500 has been developed, manufactured and tested in accordance with the following EU Directives:

- Pressure Equipment Directive 2014/68/EU
- ATEX Directive 2014/34/EU
- EMC Directive 2014/30/EU
- Measuring Instrument Directive 2014/32/EU

Conformity with the above Directives has been determined and the CE label attached to the device.

### 9.1.2 Standards compatibility

The FLOWSIC500 conforms to the following standards or recommendations:

- OIML R137-1&2, 2012  
Gas Meters - Part 1: Metrological And Technical Requirements; Part 2: Metrological Controls And Performance Tests
- EN 60079-0:2012/A11:2013, EN 60079-11:2012, EN 60079-28:2007  
Explosive atmospheres - Part 0: Equipment - General requirements; Part 11: Equipment protection by intrinsic safety "i"; Part 28: Protection of equipment and transmission systems using optical radiation
- IEC 60079-0: 2011, IEC 60079-28: 2011 (6th Edition)  
Explosive atmospheres - Part 0: Equipment - General requirements; Part 28: Protection of equipment and transmission systems using optical radiation
- IEC 60079-11: 2011+Cor.: 2012 (6th Edition)  
Explosive atmospheres - Part 11: Equipment protection by intrinsic safety "i"
- EN 61326-1:2006  
Electrical equipment for measurement, control and laboratory use - EMC requirements - Part 1: General requirements (IEC 61326-1:2005)
- IEC 61326:2005  
Electrical equipment for measurement, control and laboratory use - EMC requirements
- EN 61010-1:2010  
Safety requirements for electrical equipment for measurement, control, and laboratory use - Part 1: General requirements (IEC 61010-1:2010)
- IEC 61010-1:2010 + Cor.: 2011  
Safety requirements for electrical equipment for measurement, control and laboratory use - Part 1: General requirements
- EN 12405-1+A2:2010-10  
Gas meters - Conversion devices - Part 1: Volume conversion



## 9.1.3 Technical Data

| Meter characteristics and measuring parameters |  |
|--|--|
| Measured variable                              | Volume a.c., volume flow a.c.  |
| Measuring principle                            | Ultrasonic transit time difference measurement   |
| Measured medium                                | Natural gas (dry, odorized), nitrogen, air   |
| Measuring ranges                               | Volume flow a.c., DN50/2" 1.0 ... 160 m <sup>3</sup> /h (46 ... 5,650 cfh)   |
|  | Volume flow a.c., DN80/3" 2.5 ... 400 m <sup>3</sup> /h (88 ... 14,125 cfh)  |
|  | Volume flow a.c., DN100/4" 4.0 ... 650 m <sup>3</sup> /h (141 ... 22,955 cfh)  |
|  | Volume flow a.c., DN150/6" 4.0 ... 1,000 m <sup>3</sup> /h (141 ... 35,314 cfh)  |
| Repeatability                                  | ≤ 0.1%   |
| Accuracy                                       | Accuracy class 1, typical error limits<br>Q <sub>min</sub> up to 0.1 Q <sub>max</sub> : ≤ ± 1.0 %<br>0.1 Q <sub>max</sub> up to Q <sub>max</sub> : ≤ ± 0.5 %   |
|  | Accuracy class 1, maximum allowed error limits:<br>Q <sub>min</sub> up to 0.1 Q <sub>max</sub> : ≤ ± 2%<br>0.1 Q <sub>max</sub> up to Q <sub>max</sub> : ≤ ± 1%<br>After HP flow rate calibration: ± 0.2% with test pressure,<br>otherwise ± 0.5%  |
| Diagnostics functions                          | Permanent monitoring of measured values  |
| Gas temperature                                | -25 °C ... +60 °C (-13 °F ... 140 °F);<br>optional: -40 °C ... +70 °C (-40 °F ... 158 °F)  |
| Operating pressure                             | PN16 (EN 1092-1, GOST 12815-80): 0 bar (g) ... 16 bar (g)<br>Class 150 (ASME B16.5): 0 bar (g) ... 20 bar (g)  |
| Ambient conditions                             |  |
| Ambient temperature                            | -25 °C ... +60 °C (-13 °F ... 140 °F);<br>optional: -40 °C ... +70 °C (-40 °F ... 158 °F)  |
| Storage temperature                            | -40 °C ... +80 °C (-40 °F ... 176 °F)  |
| Electromagnetic Conditions (EMC)               | E2 in accordance with OIML R137-1&2, 2012  |
| Mechanical conditions                          | M2 in accordance with OIML R137-1&2, 2012  |
| Approvals                                      |  |
| Conformities                                   | → p. 132, §9.1   |
| Ex approvals                                   | IECEx Ex ia [ia] IIB T4 Gb, Ex ia [ia] IIC T4 Gb,<br>Ex op is IIC T4 Gb  |
|  | ATEX II 2G Ex ia [ia] IIB T4 Gb, II 2G Ex ia [ia] IIC T4 Gb,<br>II 2G Ex op is IIC T4 Gb   |
|  | NEC/CEC (US/CA) CSA: I. S. for<br>Class I, Division 1 Groups C,D T4,<br>Ex/AEx ia IIB T4 Ga  |
| IP classification                              | IP 66  |
| Outputs and interfaces                         |  |
| Digital outputs                                | Configurations:<br><ul style="list-style-type: none"> <li>● LF pulses + malfunction, electrically isolated (f<sub>max</sub> = 100 Hz),</li> <li>● HF pulses + malfunction, electrically isolated (f<sub>max</sub> = 2 kHz),</li> <li>● Encoder + LF pulses, electrically isolated (f<sub>max</sub> = 100 Hz),</li> <li>● Encoder, electrically isolated + HF pulses, not electrically isolated (f<sub>max</sub> = 2 kHz)</li> <li>● 2 x LF pulses, electrically isolated (f<sub>max</sub> = 100 Hz)</li> </ul> |
| Interfaces                                     | <ul style="list-style-type: none"> <li>● RS-485 module (external feed) <i>alternative</i> to digital outputs, protocol Modbus RTU</li> <li>● Optical interface (according to EN62056-21 (Section 4.3))</li> </ul>  |
| Installation                                   |  |
| Dimensions (W x H x D)                         | See dimensional drawings (→ p. 141, §9.4)  |
| Weight   | See dimensional drawings (→ p. 141, §9.4)  |
| Material in contact with media                 | Aluminium AC-42100-S-T6  |
| Mounting                                       | Horizontal or vertical installation with O D straight inlet/outlet piping  |

|                              |   |
|------------------------------|---|
| <b>Electrical connection</b> |   |
| Voltage                      | Intrinsically safe supply: 4.5 ... 16 V DC  |
|                              | Including 3-months backup battery   |
| Power input                  | ≤ 100 mW  |
| <b>General</b>               |   |
| Options                      | Self-sufficient meter design (typical battery service life: More than 5 years)        |
| Scope of delivery            | The scope of delivery is dependent on the application and the customer specification. |

Table 31 Technical Data (additional for device option volume conversion)

|  |   |  |
|--|---|--|
| <b>Volume conversion</b>   |   |  |
| Accuracy   | Accuracy class 0.5<br>Maximum allowed error limit of conversion factor C: $\leq \pm 0.5\%$<br>(at reference conditions)   |  |
| Conversion method  | PTZ or TZ   |  |
| Calculation methods  | <ul style="list-style-type: none"> <li>● Fixed value</li> <li>● SGERG88,</li> <li>● AGA 8 Gross method 1</li> <li>● AGA 8 Gross method 2</li> <li>● AGA NX-19</li> </ul>  | <ul style="list-style-type: none"> <li>● AGA NX-19 mod.</li> <li>● AGA NX-19 mod. GOST</li> <li>● GERG91 mod.</li> <li>● AGA8-92DC (AGA-8 detail)</li> </ul> |
| <b>Logbooks and Archives</b>   |   |  |
| Logbooks   | <ul style="list-style-type: none"> <li>● Event logbook (1000 entries)</li> <li>● Parameter logbook (250 entries)</li> <li>● Metrology logbook (100 entries)</li> <li>● Gas composition logbook (150 entries)</li> </ul> |  |
| Archives   | <ul style="list-style-type: none"> <li>● Billing archive (6000 entries)</li> <li>● Day archive (600 entries)</li> <li>● Month archive (25 entries)</li> </ul>   |  |
| <b>Pressure sensor (only for device option volume conversion)</b>    |   |  |
| Measuring ranges   | Absolute pressure sensors   | Relative pressure sensors  |
|  | 0.8 ... 5.2 bar (a)   | 0 ... 4 bar (g)  |
|  | 2.0 ... 10.0 bar (a)  | 0 ... 10 bar (g)   |
|  | 4.0 ... 20.0 bar (a)  | 0 ... 20 bar (g)   |
| <b>Temperature sensor (only for device option volume conversion)</b> |   |  |
| Measuring ranges   | -25 ... +60 ° C   |  |
|  | -40 ... +70 ° C (optional)  |  |

## 9.1.4

**Flow rates**

Table 32

Flow rates

| Meter size | G class | Measuring range [m <sup>3</sup> /h] | Measuring range [cfh] | Turndown ratio |
|------------|---------|-------------------------------------|-----------------------|----------------|
| DN50 / 2"  | G 40    | 1.3 - 65                            | 45.9 - 2,295.5        | 1 : 50         |
|            | G 65    | 2.0 - 100                           | 70.6 - 3,530.5        | 1 : 50         |
|            | G 100   | 3.2 - 160                           | 113.0 - 5,650.3       | 1 : 50         |
|            | G 100   | 1.6 - 160                           | 56.5 - 5,650.3        | 1 : 100        |
|            | G 100   | 1.0 - 160                           | 35.3 - 5,650.0        | 1 : 160        |
| DN80 / 3"  | G 100   | 3.2 - 160                           | 113.0 - 5,650.0       | 1 : 50         |
|            | G 160   | 5.0 - 250                           | 176.6 - 8,828.7       | 1 : 50         |
|            | G 160   | 2.5 - 250                           | 88.3 - 8,828.7        | 1 : 100        |
|            | G 250   | 8.0 - 400                           | 282.5 - 14,125.9      | 1 : 50         |
|            | G 250   | 4.0 - 400                           | 141.3 - 14,125.9      | 1 : 100        |
|            | G 250   | 2.5 - 400                           | 88.3 - 14,125.9       | 1 : 160        |
| DN100 / 4" | G 160   | 5.0 - 250                           | 176.6 - 8,828.7       | 1 : 50         |
|            | G 250   | 8.0 - 400                           | 282.5 - 14,125.9      | 1 : 50         |
|            | G 250   | 4.0 - 400                           | 141.3 - 14,125.9      | 1 : 100        |
|            | G 400   | 13.0 - 650                          | 459.1 - 22,954.5      | 1 : 50         |
|            | G 400   | 6.5 - 650                           | 229.5 - 22,954.5      | 1 : 100        |
|            | G 400   | 4.0 - 650                           | 141.3 - 22,954.5      | 1 : 160        |
| DN150 / 6" | G 250   | 8.0 - 400                           | 282.5 - 14,125.9      | 1 : 50         |
|            | G 250   | 4.0 - 400                           | 141.3 - 14,125.9      | 1 : 100        |
|            | G 400   | 13.0 - 650                          | 459.1 - 22,954.5      | 1 : 50         |
|            | G 400   | 6.5 - 650                           | 229.5 - 22,954.5      | 1 : 100        |
|            | G 400   | 4.0 - 650                           | 141.3 - 22,954.5      | 1 : 160        |
|            | G 650   | 20.0 - 1,000                        | 706.3 - 35,314.7      | 1 : 50         |
|            | G 650   | 10.0 - 1,000                        | 353.1 - 35,314.7      | 1 : 100        |
|            | G 650   | 6.2 - 1,000                         | 219.0 - 35,314.7      | 1 : 160        |
|            | G 650   | 5.0 - 1,000                         | 176.6 - 35,314.7      | 1 : 200        |
|            | G650    | 4.0 - 1,000                         | 141.3 35,314.7        | 1 : 250        |

## 9.1.5

**Overload protection**

Table 33

Overload protection

| Meter size | Q <sub>max</sub>    |        | Overload protection   |                     |          |
|------------|---------------------|--------|-----------------------|---------------------|----------|
|            | [m <sup>3</sup> /h] | [cfh]  |                       | [m <sup>3</sup> /h] | [cfh]    |
| DN50 / 2"  | 160                 | 5,650  | 150% Q <sub>max</sub> | 240                 | 8,475    |
| DN80 / 3"  | 400                 | 14,125 | 150% Q <sub>max</sub> | 600                 | 21,187.5 |
| DN100 / 4" | 650                 | 22,955 | 150% Q <sub>max</sub> | 975                 | 34,432.5 |
| DN150 / 6" | 1,000               | 35,314 | 120% Q <sub>max</sub> | 1,200               | 42,376.8 |

## 9.2

**Type code**

Fig. 62

Type code FLOWSIC500 (overview)

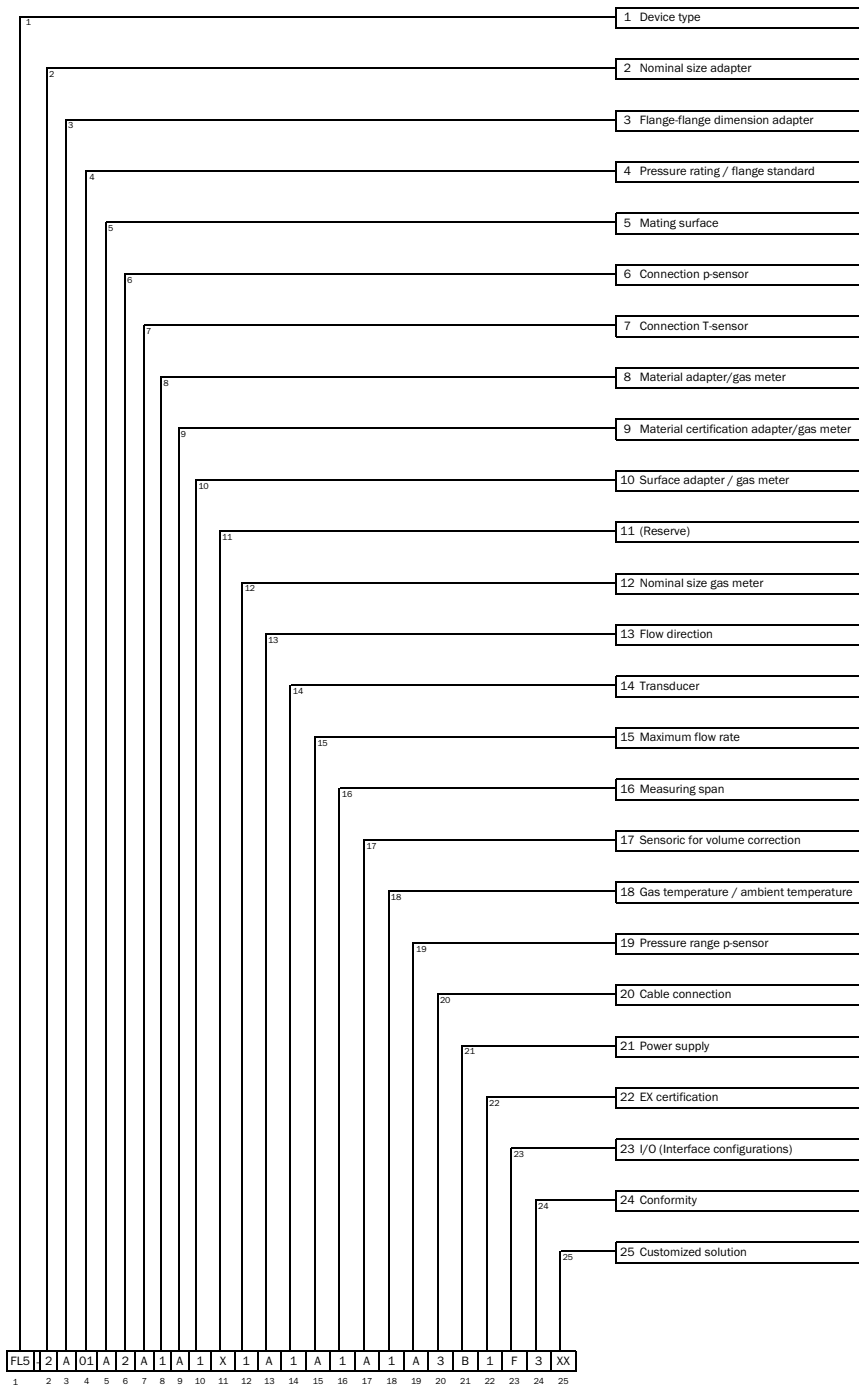

Fig. 63 Type code FLOWSIC500 (explanation)

|  |   |  |  |
|--|---|--|--|
| <b>1 Device type</b>                     | FL5 FLOWSIC500                                    | <b>17 Sensoric for volume correction</b>           | A -  |
| <b>2 Nominal size adapter</b>            | X Replacement meter only                          | B T-Sensor external                                | C T-Sensor internal                            |
| 1 DN 50 / 2"                             | 2 DN 80 / 3"                                      | D p/T-Sensoren external                            | E p/T-Sensoren internal                        |
| 3 DN100 / 4"                             | D DN150 / 6", adapter 4"                          | <b>18 Gas temperature/ambient temperature</b>      | 1 -25°C ... +60°C / -25°C ... +60°C            |
| <b>3 Flange-flange dimension adapter</b> | X Replacement meter only                          | 3 -40°C ... +70°C / -40°C ... +70°C                | <b>19 Pressure range p-Sensor</b>              |
| A 50 mm                                  | B 171 mm  | A -  | B absolute 0,8 ... 5,2 bar                     |
| E 241 mm                                 | G 300 mm  | C absolute 2,0 ... 10,0 bar                        | D absolute 4,0 ... 20,0 bar                    |
| L 450 mm                                 | <b>4 Pressure rating / flange standard</b>        | F relative 0 ... 4,0 bar / 0 ... 58,0 PSI          | G relative 0 ... 10,0 bar / 0 ... 145,0 PSI    |
| <b>5 Mating surface</b>                  | 01 PN16 / EN1092-1                                | H relative 0 ... 25,0 bar / 0 ... 362,6 PSI        | <b>20 Cable connection</b>                     |
| A Flat face, smooth finish               | 02 Class 150 / ASME B16.5                         | 1 2x M12, 2x M8                                    | 3 2x M12                                       |
| B Raised face, smooth finish             | <b>6 Connection p-sensor</b>                      | <b>21 Power supply</b>                             | B External with backup battery                 |
| C Form A / DIN EN 1092-1                 | X Replacement meter only                          | C Autarkic with battery pack (5 years)             | <b>22 EX certification</b>                     |
| D Form B1 / DIN EN 1092-1                | 1 Plug NPT 1/4"                                   | 1 ATEX Zone 1 / IEC-Ex Zone 1, Group IIB           | 2 ATEX Zone 1 / IEC-Ex Zone 1, Group IIC       |
| <b>7 Connection T-sensor</b>             | 2 Plug G1/4"                                      | 3 CSA Class 1 Div 1, Group CD                      | <b>23 I/O (Interface configurations)</b>       |
| A without                                | 3 Compression fitting 1/4"                        | A Impulse LF + Status (not galvanically isolated)  | B Impulse HF (galvanically isolated)           |
| E 2x G 1/2" plug                         | 4 Compression fitting D6                          | C Encoder  | D RS485 (externally powered)                   |
| <b>8 Material adapter/gas meter</b>      | <b>9 Material certification adapter/gas meter</b> | E Encoder + Impulse (not galvanically isolated)    | F Impulse LF + Status (galvanically isolated)  |
| 1 Aluminum / aluminum                    | A 3.1 / 3.1                                       | G Impulse HF + Status (galvanically isolated)      | H Encoder + Impulse LF (galvanically isolated) |
| <b>10 Surface adapter/gas meter</b>      | <b>11 Reserve</b>                                 | I RS485 Modul - battery powered (external)         | J RS485 Modul - line powered (external)        |
| 1 Shot-peened / SICK standard            | X -   | K Encoder + Impulse HF (not galvanically isolated) | L 2 x LF-Impulses (galvanically isolated)      |
| <b>12 Nominal size gas meter</b>         | <b>13 Flow direction</b>                          | <b>24 Conformity</b>                               | 2 PED  |
| 1 DN 50 / 2"                             | A Left - right                                    | 3 MID, PED   | <b>25 Customized solution</b>                  |
| 2 DN 80 / 3"                             | B Right - left                                    | XX -   |  |
| 3 DN100 / 4"                             | <b>14 Transducer</b>                              |  |  |
| C DN150 / 6"                             | 1 Type 1: 300 kHz                                 |  |  |
| <b>15 Maximum flow rate</b>              | <b>16 Measuring span</b>                          |  |  |
| A Qmax 65 m <sup>3</sup> /h              | 1 1:50  |  |  |
| B Qmax 100 m <sup>3</sup> /h             | 2 1:100   |  |  |
| C Qmax 160 m <sup>3</sup> /h             | 3 1:160   |  |  |
| D Qmax 250 m <sup>3</sup> /h             | 4 1:200   |  |  |
| E Qmax 400 m <sup>3</sup> /h             | 9 1:250   |  |  |
| F Qmax 650 m <sup>3</sup> /h             |   |  |  |
| G Qmax 1000 m <sup>3</sup> /h            |   |  |  |

## 9.3 Type plates

### 9.3.1 Metrology and electronics type plates

Fig. 64 Legend for type plates

| Variable | Bezeichnung   | Description   |
|----------|---|---|
| 00       | Typschlüssel  | Type code   |
| 01       | Artikelnummer Gaszähler (Materialnr.)                               | Part number gas meter (material number)                             |
| 02       | Seriennummer  | Serial number   |
| 02.1     | Seriennummer (XXXX XXXX)  | Serial number (XXXX XXXX)   |
| 03       | Datum (MM/JJJJ)   | date (MM/YYYY)  |
| 04       | Min. Umgebungstemperatur  | Min. ambient temperature  |
| 05       | Max Umgebungstemperatur   | Max. ambient temperature  |
| 06       | Min. Mediumstemperatur  | Min. gas temperature  |
| 07       | Max. Mediumstemperatur  | Max. gas temperature  |
| 08       | Max. Durchfluss   | Max. flow rate  |
| 09       | Min. Durchfluss   | Min. flow rate  |
| 10       | Trenndurchfluss   | Transition flow rate  |
| 11       | Nennweite   | Size  |
| 12       | Jahr (metrologisch) (JJ)  | Year (metrological) (YY)  |
| 13       | Datamatrix-Code 01(M)+02(S)<br>Format: MMMMMMMSSSSSSSS              | Datamatrix-Code 01(M)+02(S)<br>Format: MMMMMMMSSSSSSSS              |
| 13.1     | Datamatrix-Code 01(M)+7SIC00+02(S)<br>Format: MMMMMMM7SIC00SSSSSSSS | Datamatrix-Code 01(M)+7SIC00+02(S)<br>Format: MMMMMMM7SIC00SSSSSSSS |
| 16       | Belegung PIN 1_1  | PIN assignment 1_1  |
| 17       | Belegung PIN 1_2  | PIN assignment 1_2  |
| 18       | Belegung PIN 2_1  | PIN assignment 2_1  |
| 19       | Belegung PIN 2_2  | PIN assignment 2_2  |
| 20       | Belegung PIN 2_3  | PIN assignment 2_3  |
| 21       | Belegung PIN 2_4  | PIN assignment 2_4  |
| 22       | Platzhalter Angaben EVCD  | Placeholder label EVCD  |
| 23       | Platzhalter Angaben CE  | Placeholder label CE  |
| 24       | Platzhalter variable Kennzeichnung                                  | Placeholder variable sign   |
| 25       | Durchmesser - 7/8"DNXX  | diameter - 7/8"DNXX   |
| 26       | Gewicht Gaszähler, inkl. Adapter                                    | Weight gas meter, including adapter                                 |
| 30       | Einheit der Temperatur 04/05/06/07                                  | unit of temperature 04/05/06/07                                     |
| 31       | Einheit des Volumenstroms 08/09/10                                  | unit of volume flow 08/09/10  |
| 32       | Einheit der Länge 25  | unit of length 25   |
| 33       | Einheit des Gewichts 26   | unit of weight 26   |

#### 9.3.1.1 Identification according to ATEX/IECEx

Fig. 65 Metrology and electronics type plate (example)

**SICK** SICK Engineering GmbH  
Bergener Ring 27  
D-01458 Ottendorf-Okrilla  
CE 0044

**FLOWSIC500** Made in Germany ID: 7 SIC00 1451.0014

Part No. 1234567  
Serial No. 12345678  
Year 08/2015

**GAS METER** **SIZE-100**  
For use with ADAPTER SIZE-100 only!  
TEC: DE-15-MI002-PTB001

Q<sub>max</sub> 2.5m<sup>3</sup>/h M2, E2, IP66  
Q<sub>t</sub> 40m<sup>3</sup>/h MPE 1.0%  
Q<sub>min</sub> 400m<sup>3</sup>/h

T<sub>amb</sub> -40°C...+70°C  
T<sub>gas</sub> -40°C...+70°C

For value P<sub>1</sub> and C<sub>1</sub> see display

**VOLUME CONVERSION DEVICE**  
TEC: DE-15-MI002-PTB003

MPE 0.5% EN12405-1  
at reference conditions  
more info: press key

FLS-2G01D1E1A2x2A1DA33A1B1F  
II 2 G Ex ia [ia] IIC T4 Gb  
II 2 G Ex op is IIC T4 Gb  
BVS 19 ATEX E 067 X  
Ex ia [ia] IIC T4 Gb  
Ex op is IIC T4 Gb  
IECEx BVS 19.0061X

**WARNING:** Explosion Hazard  
Read Operation Instructions  
before installation.  
Install per drawing no. 9215966

**Ext. Power Supply:**  
nom. 4.5...16 Vdc; max. 50 mA  
U = 20 V; I = 667 mA; P = 753 mW

**SICK** SICK Engineering GmbH  
Bergener Ring 27  
D-01458 Ottendorf-Okrilla  
CE 0044

**FLOWSIC500** Made in Germany ID: 7 SIC00 02.1

Part No. 01  
Serial No. 02  
Year 03

**GAS METER** **SIZE-100**  
For use with ADAPTER SIZE-11 only!  
TEC: DE-15-MI002-PTB001

Q<sub>max</sub> 09 31 M2, E2, IP66  
Q<sub>t</sub> 10 31 MPE 1.0%  
Q<sub>min</sub> 08 31

T<sub>amb</sub> 04 30, 05 30  
T<sub>gas</sub> 06 30, 07 30

For value P<sub>1</sub> and C<sub>1</sub> see display

**VOLUME CONVERSION DEVICE**  
TEC: DE-15-MI002-PTB003

MPE 0.5% EN12405-1  
at reference conditions  
more info: press key

II 2 G Ex ia [ia] IIC T4 Gb  
II 2 G Ex op is IIC T4 Gb  
BVS 19 ATEX E 067 X  
Ex ia [ia] IIC T4 Gb  
Ex op is IIC T4 Gb  
IECEx BVS 19.0061X

**WARNING:** Explosion Hazard  
Read Operation Instructions  
before installation.  
Install per drawing no. 9215966

**Ext. Power Supply:**  
nom. 4.5...16 Vdc; max. 50 mA  
U = 20 V; I = 667 mA; P = 753 mW



22 **VOLUME CONVERSION DEVICE**  
TEC: DE-15-MI002-PTB003  
MPE 0.5% EN12405-1  
at reference conditions  
more info: press key

Fig. 66 Pin assignment of plug-in connectors (example)

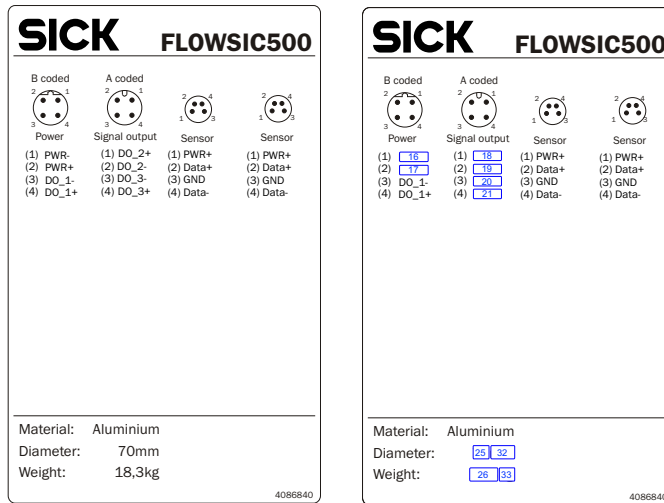

9.3.1.2 Identification according to CSA

Fig. 67 Metrology type plate (example)

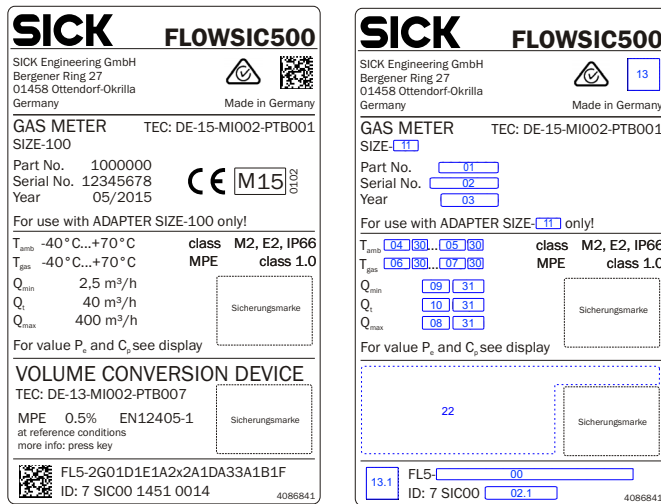
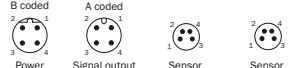



Fig. 68

Electronics type plate (example)

| SICK FLOWSIC500  |  |
|--|--|
| FL5-2G01D1E1A2x2A1DA33A1B1F  |  |
| Part No. 1000000   | Serial No. 10000000                                  |
| Cl. I, Div. 1., Groups C and D: T4<br>Ex ia IIB T4 Ga<br>Cl. I, Zone 0 AEx ia IIB T4 Ga<br>CSA 13.2566240 Exia Intrinsically Safe<br>T <sub>amb</sub> -40 °C...+70 °C Type 3R<br>Ext. Power Supply:<br>nom.: --- 4.5...16 Vdc; max. 50 mA<br>U = 20 V; I <sub>i</sub> = 667 mA; P = 772 mW |  |
| <b>WARNING/AVERTISSEMENT:</b><br>Substitution of components<br>may impair Intrinsic Safety.<br>La substitution de composants peut<br>compromettre la securite intrinseque.<br>Install per drawing no. 9215965  |  |
| B coded      A coded<br>  |  |
| (1) PWR-<br>(2) PWR+<br>(3) DO 1-<br>(4) DO 1+   | (1) DO 2+<br>(2) DO 2-<br>(3) DO 3-<br>(4) DO 3+     |
| (1) PWR<br>(2) Data+ (A)<br>(3) GND<br>(4) Data- (B)   | (1) PWR<br>(2) Data+ (A)<br>(3) GND<br>(4) Data- (B) |
| Diameter: 70mm   | Material: Aluminium                                  |
| Weight: 18,3kg   | 4073416  |

| SICK FLOWSIC500  |  |
|--|--|
| FL5-00   |  |
| Part No. 01  | Serial No. 02  |
| Cl. I, Div. 1., Groups C and D: T4<br>Ex ia IIB T4 Ga<br>Cl. I, Zone 0 AEx ia IIB T4 Ga<br>CSA 13.2566240 Exia Intrinsically Safe<br>T <sub>amb</sub> 04 30...05 30 Type 3R<br>Ext. Power Supply:<br>nom.: --- 4.5...16 Vdc; max. 50 mA<br>U = 20 V; I <sub>i</sub> = 667 mA; P = 772 mW |  |
| <b>WARNING/AVERTISSEMENT:</b><br>Substitution of components<br>may impair Intrinsic Safety.<br>La substitution de composants peut<br>compromettre la securite intrinseque.<br>Install per drawing no. 9215965  |  |
| B coded      A coded<br>  |  |
| (1) 18<br>(2) 17<br>(3) DO 1-<br>(4) DO 1+   | (1) 19<br>(2) 18<br>(3) 20<br>(4) 21                 |
| (1) PWR<br>(2) Data+ (A)<br>(3) GND<br>(4) Data- (B)   | (1) PWR<br>(2) Data+ (A)<br>(3) GND<br>(4) Data- (B) |
| Diameter: 25 32  | Material: Aluminium                                  |
| Weight: 26 33  | 4073416  |

## 9.3.2

## Type plate, Pressure Equipment Directive

Fig. 69

Type plate, Pressure Equipment Directive (example)

| SICK ADAPTER        |                     |
|---------------------|---------------------|
| SIZE-100 FLOWSIC500 |                     |
| CE 0082             | 0082                |
| Part No. 4000000    | Serial No. 12345678 |
| Year 06/2015        | TS -25/+60 °C       |
| PS 16 bar           | PT 30 bar           |
| Cat. II Fluid Gr.1  | DN100 PN16          |
| NL 300mm            | 4074278             |

| SICK ADAPTER       |               |
|--------------------|---------------|
| SIZE-13            |               |
| CE 0082            | 10            |
| Part No. 01        | Serial No. 02 |
| Year 03            | TS 07 23      |
| PS 08 22           | PT 09 22      |
| Cat. II Fluid Gr.1 | DN 04 PN 05   |
| NL 06 20           | 4074278       |

| Variable | Bezeichnung  | Description  |
|----------|--|--|
| 01       | Artikelnummer (Adapter)                                  | Part number (Adapter)                                    |
| 02       | Seriennummer (SSSSSSSS) (Adapter)                        | Serial number (SSSSSSSS) (Adapter)                       |
| 03       | Datum (MM/YYYY)  | Date (MM/YYYY)   |
| 04       | Nennweite Adapter  | Adapter size   |
| 05       | Druckstufe   | Pressure rating  |
| 06       | Nennlänge  | Flange to flange dimension                               |
| 07       | Einsatztemperaturbereich (Format: -min/+max)             | Temperature range (format: -min/+max)                    |
| 08       | Max. Betriebsüberdruck                                   | Max. operating overpressure                              |
| 09       | Prüfüberdruck  | Pressure   |
| 10       | Datamatrix-Code 01(M) + 02(S)<br>Format: MMMMMMMSSSSSSSS | Datamatrix-Code 01(M) + 02(S)<br>Format: MMMMMMMSSSSSSSS |
| 11       | Jahr (metrologisch) (YY)                                 | Year (Metrological) (YY)                                 |
| 12       | Label Gerätetyp (FLOWSIC500 oder FLOWSIC500 CIS)         | Label device type(FLOWSIC500 or FLOWSIC500 CIS)          |
| 13       | Nennweite  | Size   |
| 20       | Einheit zur Nennlänge 08                                 | Unit of nominal length 08                                |
| 21       | Einheit zur Temperatur 09                                | Unit of temperature 09                                   |
| 22       | Einheit zum Druck 10 & 11                                | Unit of pressure 10 & 11                                 |



## 9.4

**Dimensional drawings**

Fig. 70

Dimensions

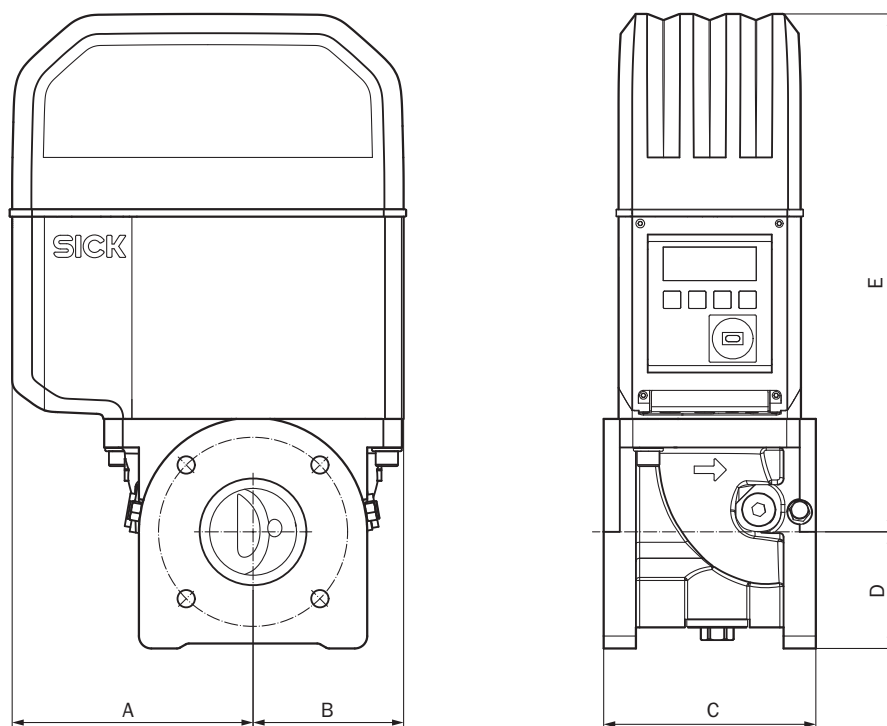

Table 34

Dimensions metrical (imperial)<sup>[1]</sup>

|                  | DN50 (2")      |               | DN80 (3")      |               | DN100 (4")     |                | DN150 (6")     |
|------------------|----------------|---------------|----------------|---------------|----------------|----------------|----------------|
| A                | 153<br>(6.02)  |               | 194<br>(7.64)  |               | 231<br>(9.09)  |                | 232<br>(9.13)  |
| B                | 78<br>(3.07)   |               | 121<br>(4.76)  |               | 159<br>(6.26)  |                | 158<br>(6.22)  |
| C <sup>[2]</sup> | 150<br>(5.91)  | 171<br>(6.73) | 171<br>(6.73)  | 241<br>(9.49) | 241<br>(9.49)  | 300<br>(11.81) | 450<br>(17.72) |
| D                | 71<br>(2.80)   |               | 94<br>(3.70)   |               | 108<br>(4.25)  |                | 143<br>(5.63)  |
| E                | 272<br>(10.71) |               | 417<br>(16.42) |               | 476<br>(18.74) |                | 476<br>(18.74) |
| Weight           | 11<br>(24.25)  | 11<br>(24.25) | 19<br>(42)     | 21<br>(46.3)  | 28<br>(61.7)   | 30<br>(66.1)   | 35<br>(77.1)   |

[1] All dimensions in mm (inch), weights in kg (lb)

[2] C = fitting length, two fitting lengths are available for meter sizes DN50 (2") to DN100 (4").

## 9.5 Internal terminal assignment

Fig. 71 Terminal assignment

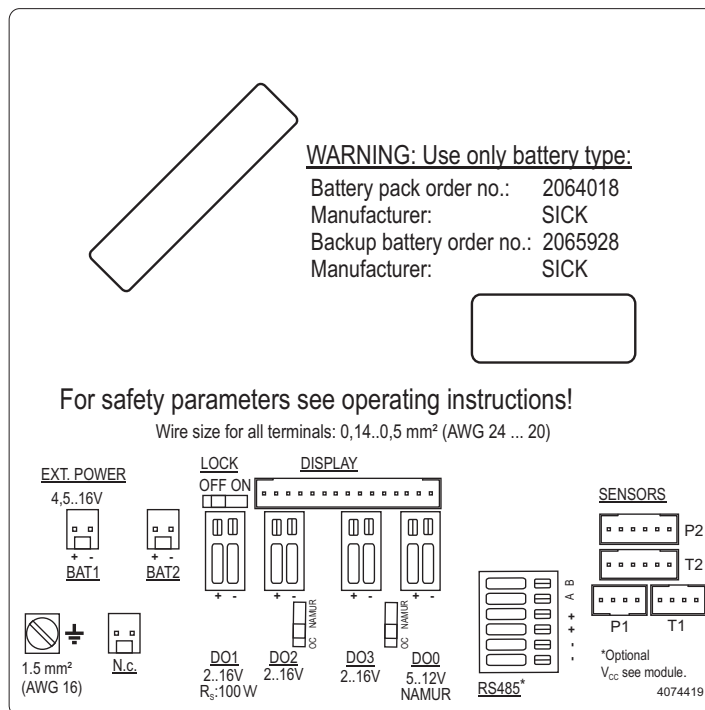

9.6 **Installation examples**

Fig. 72 Battery operation

FLAWSIC500 with LF output connected to electronic volume corrector  
(both battery powered and intrinsically safe)

Hazardous area

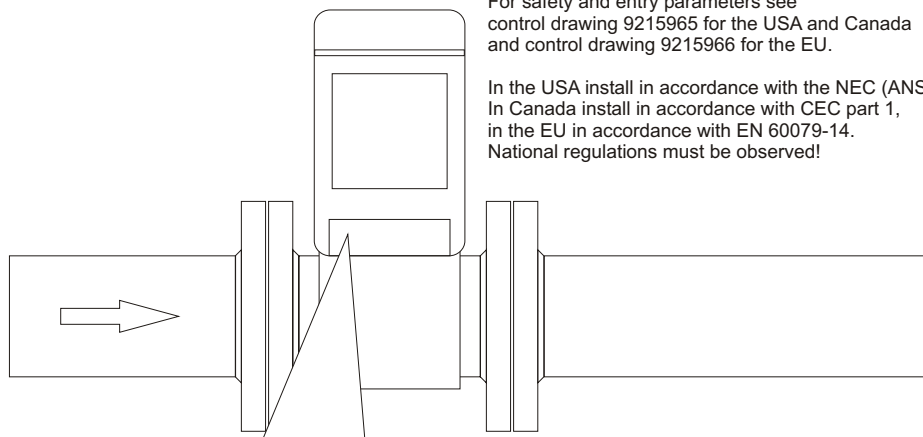
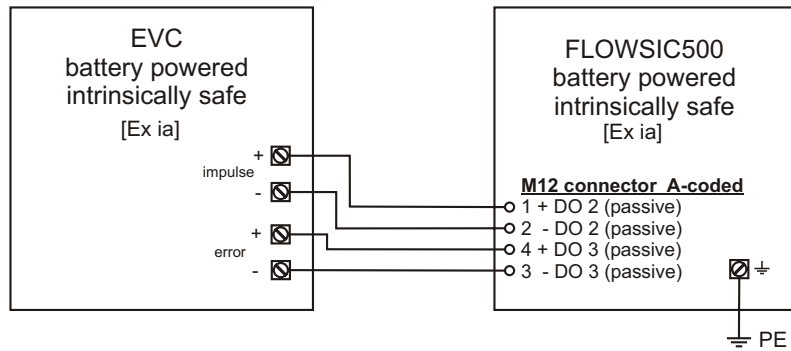

For safety and entry parameters see control drawing 9215965 for the USA and Canada and control drawing 9215966 for the EU.

In the USA install in accordance with the NEC (ANSI/NFPA70)  
In Canada install in accordance with CEC part 1,  
in the EU in accordance with EN 60079-14.  
National regulations must be observed!

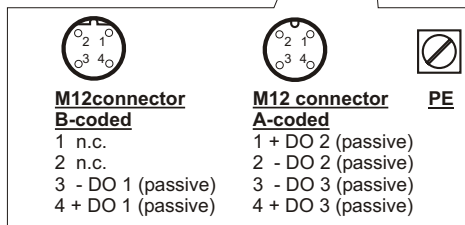

**WARNING!**  
Incorrect cabling can cause the FLOW SIC500 to fail!  
See Operating Instructions for further details!

Subject to change without notice

Fig. 73 Operation with safety barrier and external power supply

FLWSIC500 with HF output powered with safety barrier and external power supply, connected to electronic volume corrector

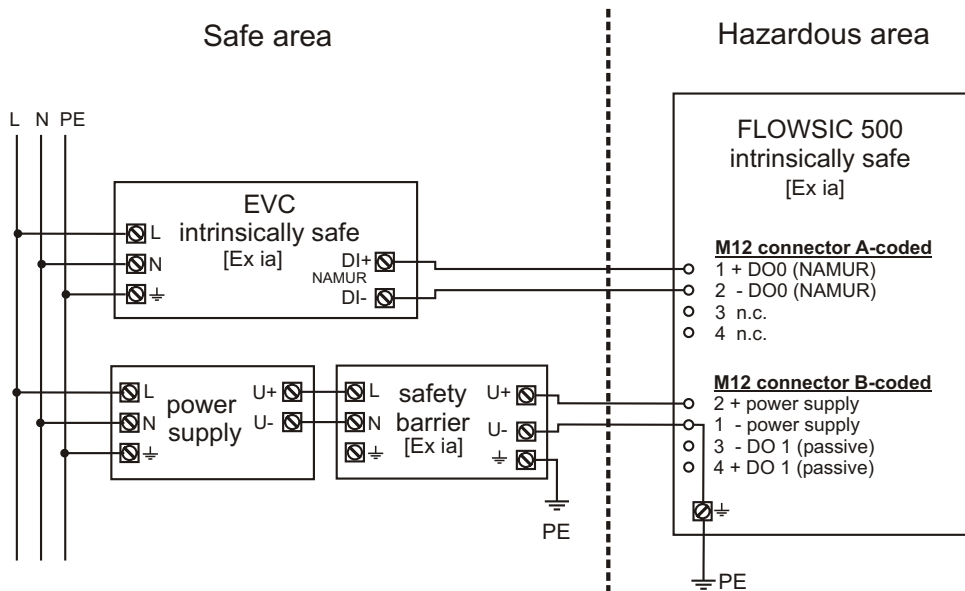

For safety and entry parameters see control drawing 9215965 for the USA and Canada and control drawing 9215966 for the EU.

In the USA install in accordance with the NEC (ANSI/NFPA70), in Canada install in accordance with CEC part 1, in the EU install in accordance with EN 60079-14. Further national regulations must be observed!

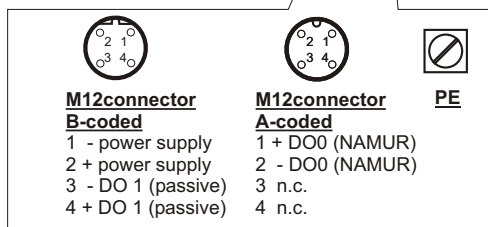
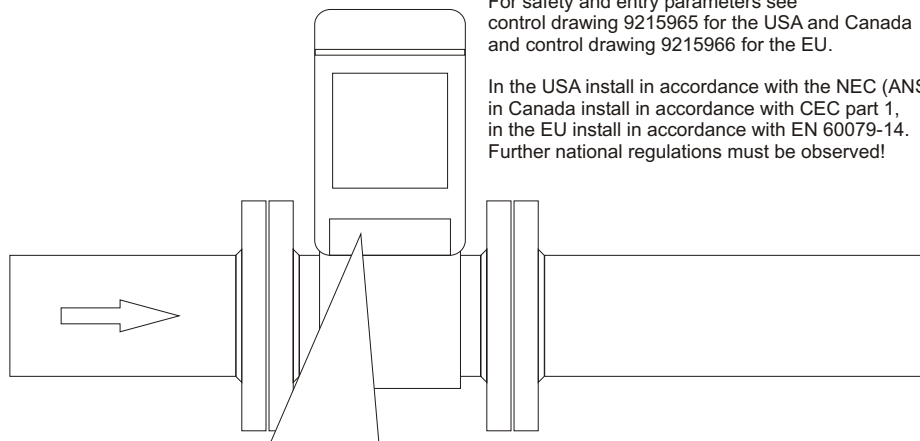

**WARNING!**

Incorrect cabling can cause the FLOW SIC500 to fail! See Operating Instructions for further details!

**Attention!**

DO0 is optically insulated. Do not use as HF output in battery powered mode! Frequent activity results in a reduced battery life time.

Subject to change without notice

Fig. 74 Operation with external power supply (intrinsically safe)

FLWSIC500 externally powered (IS) and connected to electronic volume corrector, RS485 externally powered

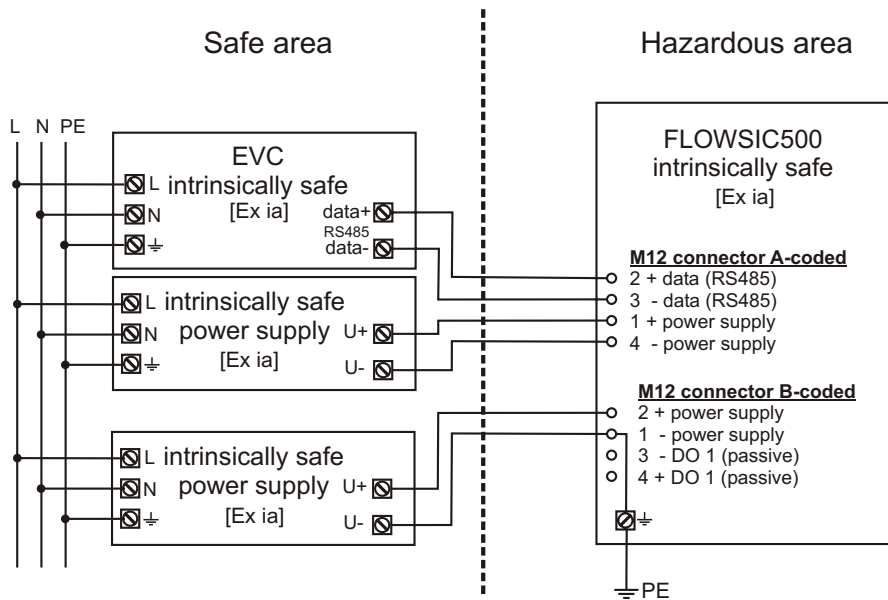

For safety and entry parameters see control drawing 9215965 for the USA and Canada and control drawing 9215966 for the EU.

In the USA install in accordance with the NEC (ANSI/NFPA70), in Canada install in accordance with CEC part 1, in the EU install in accordance with EN 60079-14. National regulations must be observed!

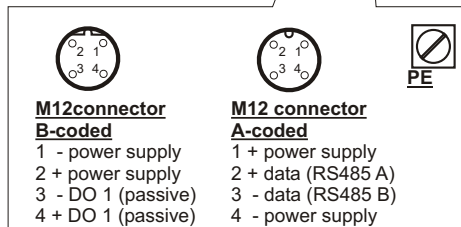
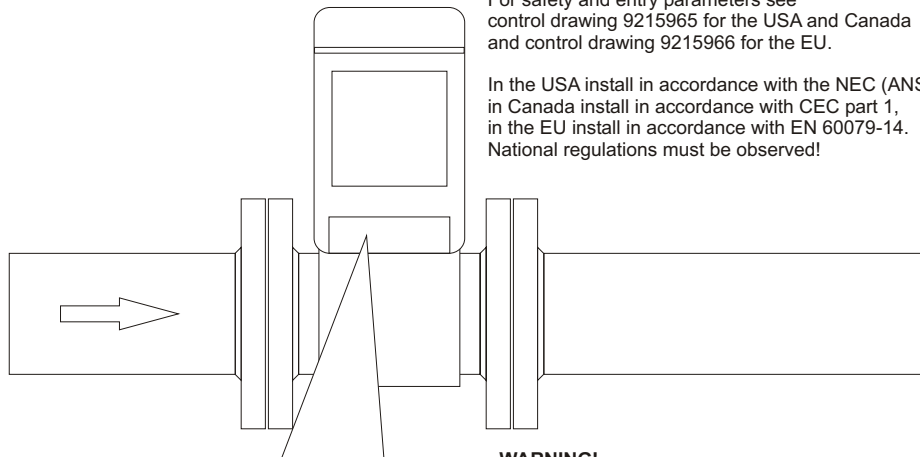

**WARNING!**  
Incorrect cabling can cause the FLOW SIC500 to fail!  
See Operating Instructions for further details!

**Attention!**  
RS485 must be powered externally!  
For environments with relevant electromagnetic disturbance and long cables, shielded cables are recommended.

Subject to change without notice

9.7 **Connection diagrams for operation of the FLOWSIC500 in accordance with CSA**

Fig. 75 Control diagram 9215965 (page 1)

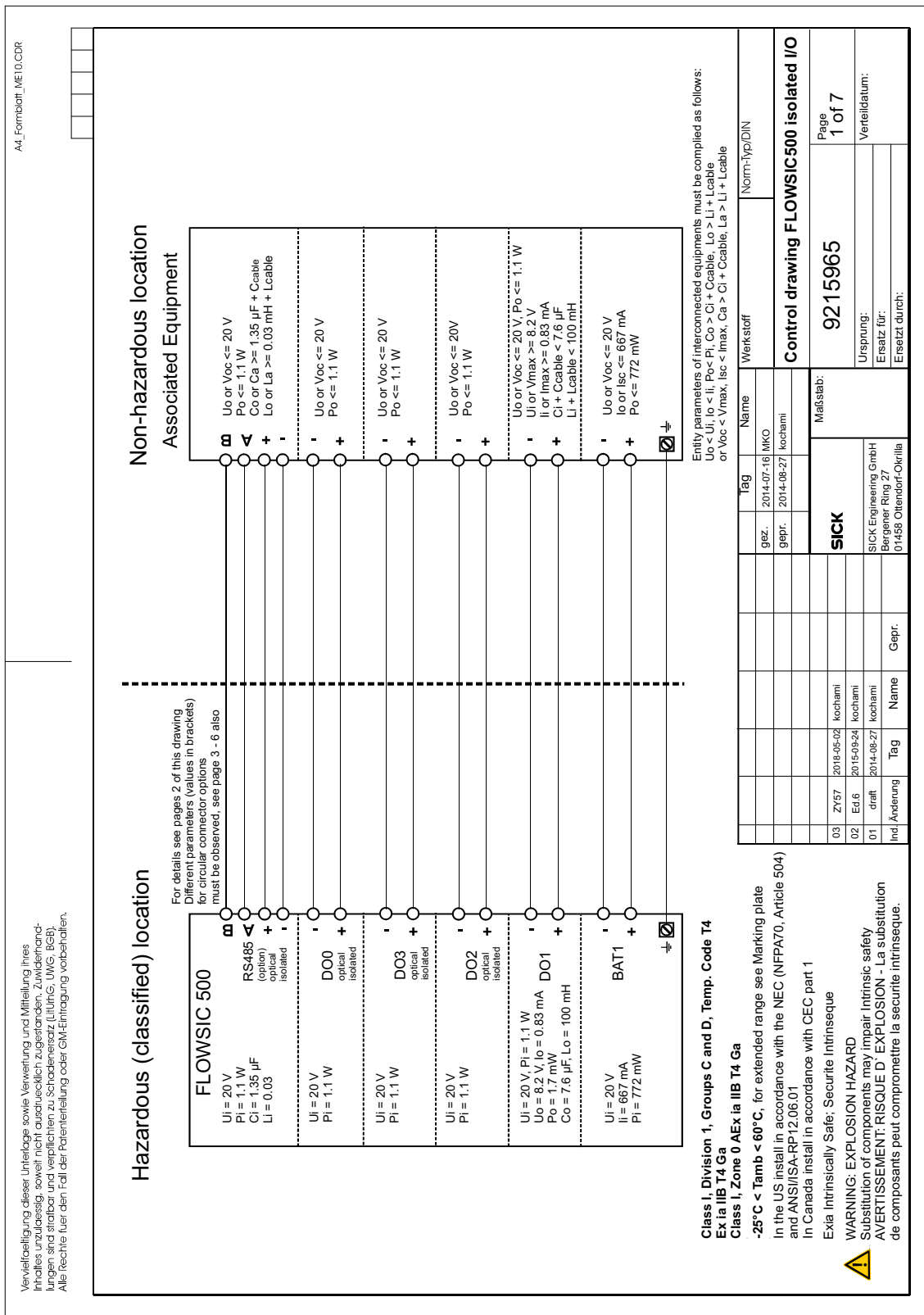

Fig. 76 Control diagram 9215965 (page 2)

Subject to change without notice

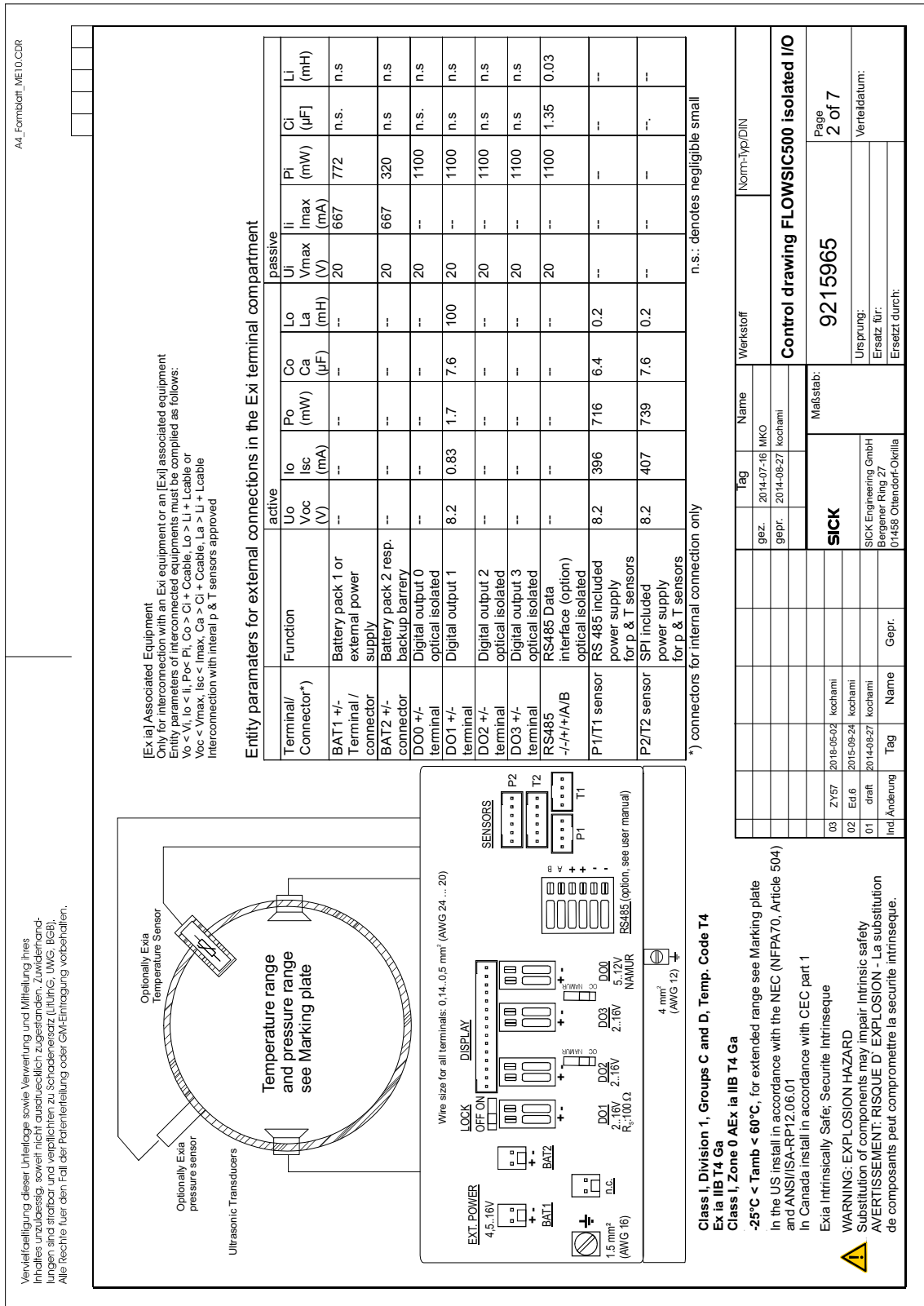
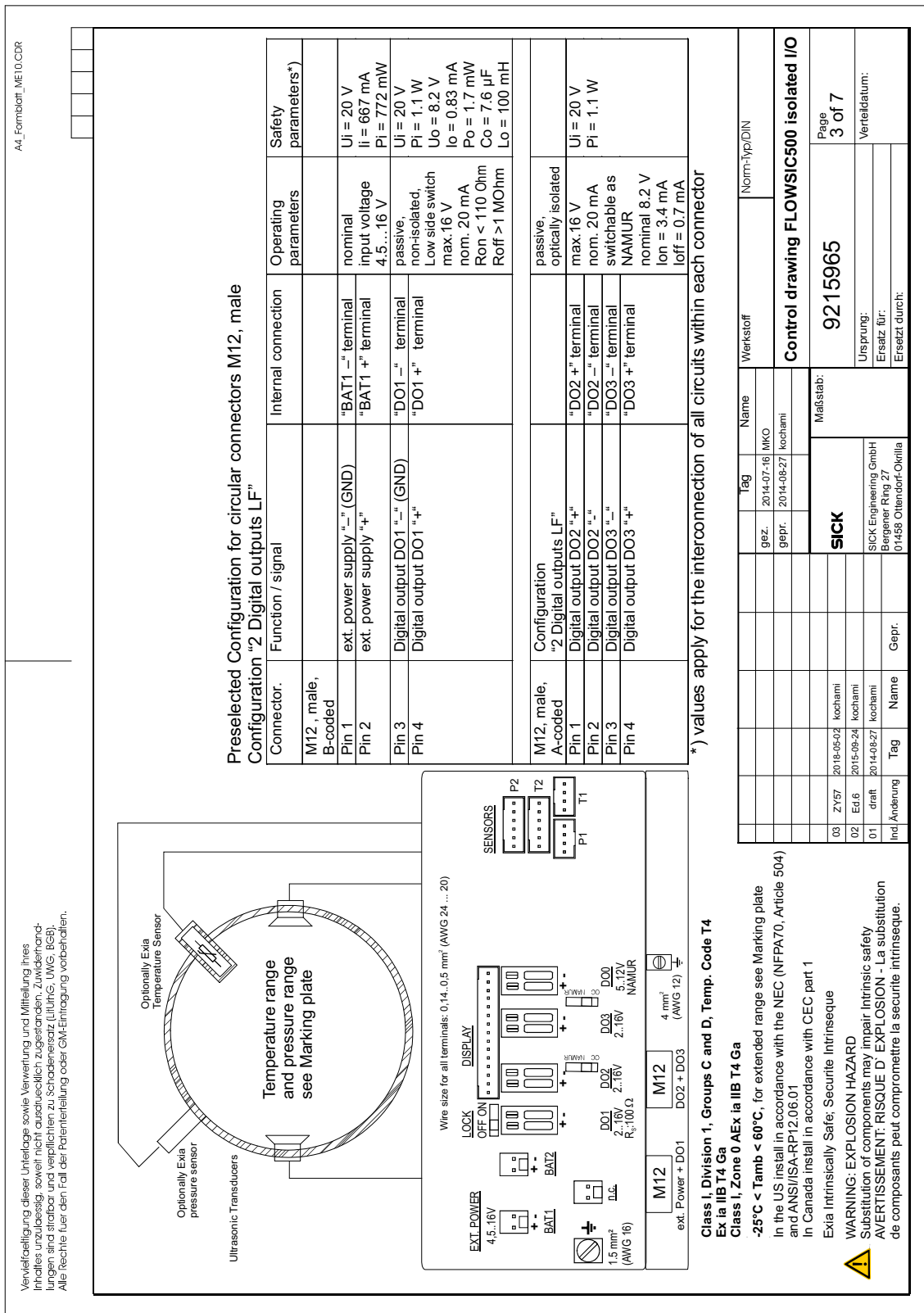

Fig. 77 Control diagram 9215965 (page 3)



Subject to change without notice



Fig. 78 Control diagram 9215965 (page 4)

Subject to change without notice

A4\_Formblatt\_ME10.CDR

### Pre-selected Configuration for circular connectors M12, male Configuration " 2 Digital outputs HF (Encoder) + LF"

Page  
4 of 7

Vervielfältigung dieser Unterlage sowie Verwertung und Mitteilung ihres Inhaltes unzulässig, soweit nicht ausdrücklich zugestanden, zuwidernach-  
lungen sind anzuordnen und verpflichten zu Schadensersatz (Litho: UMG/BBB).  
Alle Rechte hier den Fall der Patenterteilung oder Erfindung vorbehalten.

| Connector.         | Function / signal            | Internal connection | Operating parameters                             | Safety parameters*)                                       |
|--------------------|------------------------------|---------------------|--|---|
| M12, male, B-coded |                              |                     |  |   |
| Pin 1              | ext. power supply "-" (GND)  | "BAT1 -" terminal   | nominal input voltage 4.5...16 V                 | Ui = 20 V<br>Ii = 667 mA<br>Pi = 772 mW                   |
| Pin 2              | ext. power supply "+"        | "BAT1 +" terminal   |  |   |
| Pin 3              | Digital output DO1 "-" (GND) | "DO1 -" terminal    | passive, non-isolated, Low side switch max. 16 V | Ui = 20 V<br>Pi = 1.1 W<br>Uo = 8.2 V                     |
| Pin 4              | Digital output DO1 "+"       | "DO1 +" terminal    | nom. 20 mA<br>Ron < 110 Ohm<br>Roff > 1 MOhm     | Io = 0.83 mA<br>Po = 1.7 mW<br>Co = 7.6 µF<br>Lo = 100 mH |

| Configuration      | Configuration                 | Configuration             | Configuration                     |
|--------------------|-------------------------------|---------------------------|-----------------------------------|
| M12, male, A-coded | "Digital outputs HF + LF"     | "Digital outputs HF + LF" | NAMUR / OC optically isolated     |
| Pin 1              | Digital output DO0 "+"        | "DO0 +" terminal          | nominal 8.2 V                     |
| Pin 2              | Digital output DO0 "-"        | "DO0 -" terminal          | Ion = 3.4 mA<br>Ioff = 0.7 mA     |
| Pin 3              | Digital output DO2 or DO3 "+" | "DOx +" terminal          | max. 16 V                         |
| Pin 4              | Digital output DO2 or DO3 "-" | "DOx -" terminal          | nom. 20 mA<br>switchable as NAMUR |
|                    |                               |                           | nominal 8.2 V                     |
|                    |                               |                           | Ion = 3.4 mA<br>Ioff = 0.7 mA     |

Wire size for all terminals: 0.14...0.5 mm<sup>2</sup> (AWG 24 ... 20)

\*) values apply for the interconnection of all circuits within each connector

**Class I, Division 1, Groups C and D, Temp. Code T4**  
**Ex ia IIB T4 Ga**  
**Class I, Zone 0 AEx ia IIB T4 Ga**

-25°C < Tamb < 60°C, for extended range see Marking plate  
In the US install in accordance with the NEC (NFPA70, Article 504) and ANSI/ISA-RP12.06.01  
In Canada install in accordance with CEC part 1  
Exia Intrinsically Safe; Securite Intrinseque

WARNING: EXPLOSION HAZARD  
Substitution of components may impair intrinsic safety  
AVERTISSEMENT: RISQUE D' EXPLOSION - La substitution de composants peut compromettre la securite intrinseque.

| Tag           | Name       | Werkstoff  | Norm-1yp/DIN |
|---------------|------------|------------|--------------|
| gez.          | 2014-07-16 | MKO        |              |
| gepr.         | 2014-09-27 | kochami    |              |
| <b>SICK</b>   |            |            |              |
| Maßstab:      |            |            |              |
| 03            | ZY57       | 2018-05-02 | kochami      |
| 02            | Ed.6       | 2015-09-24 | kochami      |
| 01            | draft      | 2014-05-27 | kochami      |
| Ind. Änderung | Tag        | Name       | Gepr.        |

Fig. 79 Control diagram 9215965 (page 5)

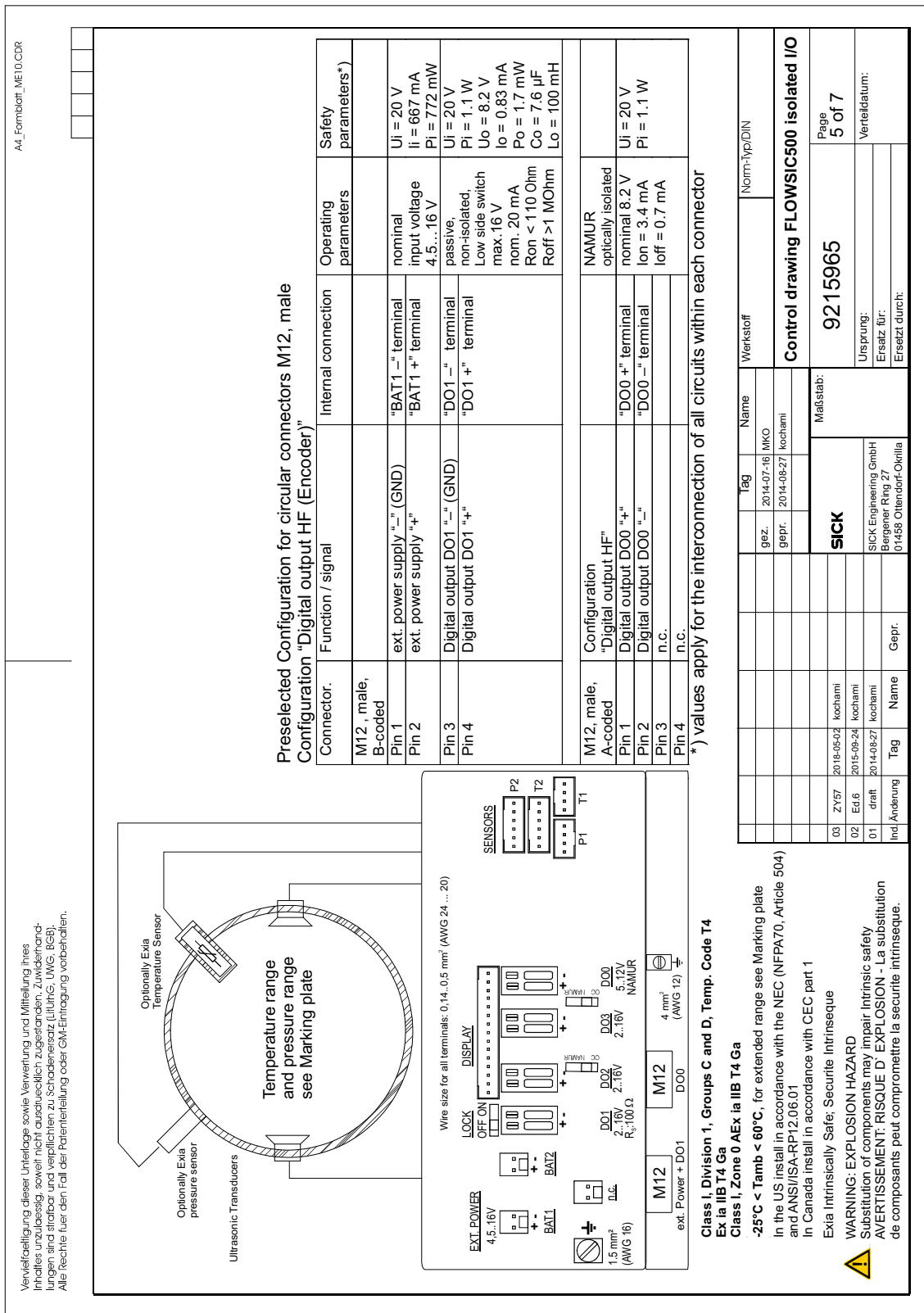

Subject to change without notice

Fig. 80 Control diagram 9215965 (page 6)

Subject to change without notice

A4\_Formblatt\_ME10.CDR

Preselcted Configuration for circular connectors M12, male  
Configuration "RS485 external powered"

| Connector          | Function / signal            | Internal connection | Operating parameters                            | Safety parameters*)  |
|--------------------|------------------------------|---------------------|---|--|
| M12, male, B-coded |                              |                     |   |  |
| Pin 1              | ext. power supply "-" (GND)  | "BAT1 -" terminal   | nominal input voltage 4.5...16 V                | Ui = 20 V<br>Ii = 667 mA<br>Pi = 772 mW  |
| Pin 2              | ext. power supply "+"        | "DO1 -" terminal    | passive, non-isolated Low side switch max. 16 V | Ui = 20 V<br>Pi = 1.1 W<br>Uo = 8.2 V<br>Io = 0.83 mA<br>Po = 1.7 mW<br>Co = 7.6 µF<br>Lo = 100 mH |
| Pin 3              | Digital output DO1 "-" (GND) | "DO1 -" terminal    |   |  |
| Pin 4              | Digital output DO1 "+"       | "DO1 +" terminal    |   |  |

\*) values apply for the interconnection of all circuits within each connector

| Configuration      | Configuration                    | Configuration      |
|--------------------|----------------------------------|--------------------|
| M12, male, A-coded | "RS485 external powered"         | optically isolated |
| Pin 1              | Auxiliary power supply input "+" | "RS485 +" terminal |
| Pin 2              | "RS485 Data Interface "A"        | "RS485 A" terminal |
| Pin 3              | Auxiliary power supply input "-" | "RS485 -" terminal |
| Pin 4              | "RS485 Data Interface "B"        | "RS485 B" terminal |

| Tag   | Name               | Werkstoff | Norm-1yp/DIN |
|-------|--------------------|-----------|--------------|
| gez.  | 2014-07-16 MKO     |           |              |
| gepr. | 2014-09-27 Kochani |           |              |

| Tag | Name  | Werkstoff          | Norm-1yp/DIN |
|-----|-------|--------------------|--------------|
| 03  | ZY57  | 2018-09-02 Kochani |              |
| 02  | Ed.6  | 2015-09-24 Kochani |              |
| 01  | draht | 2014-09-27 Kochani |              |

**SICK**

SICK Engineering GmbH  
Bergener Ring 27  
01469 Ottendorf-Okrilla

Control drawing FLOWSiC500 isolated I/O

9215965

Page 6 of 7

Verteildatum:

Ursprung:

Ersatz für:

Ersetzt durch:

Fig. 81 Control diagram 9215965 (page 7)

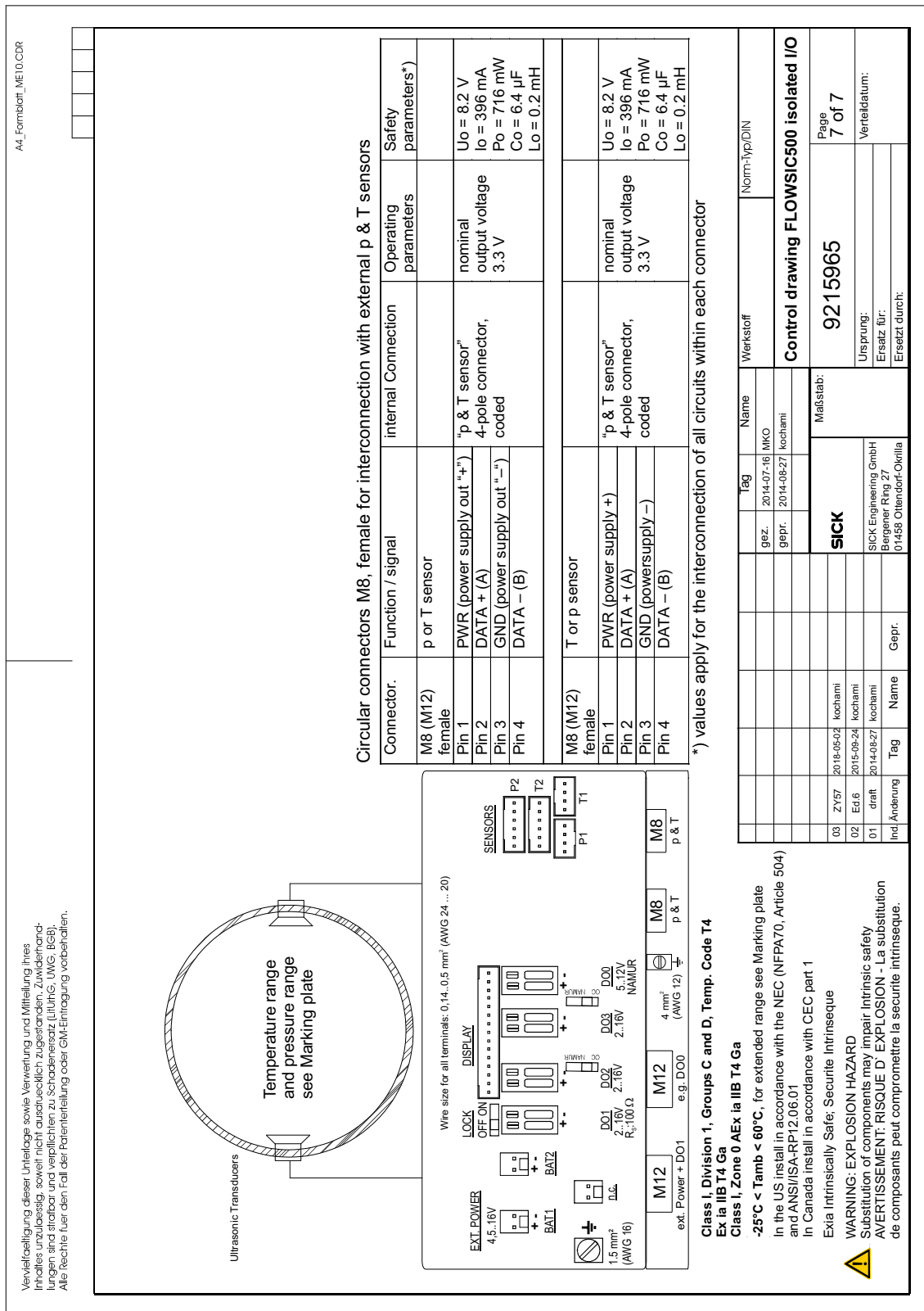

Subject to change without notice

9.8 **Connection diagrams for operation of the FLOWSIC500 in accordance with ATEX/IECEX**

Fig. 82 Control diagram 9215966 (page 1)

Subject to change without notice

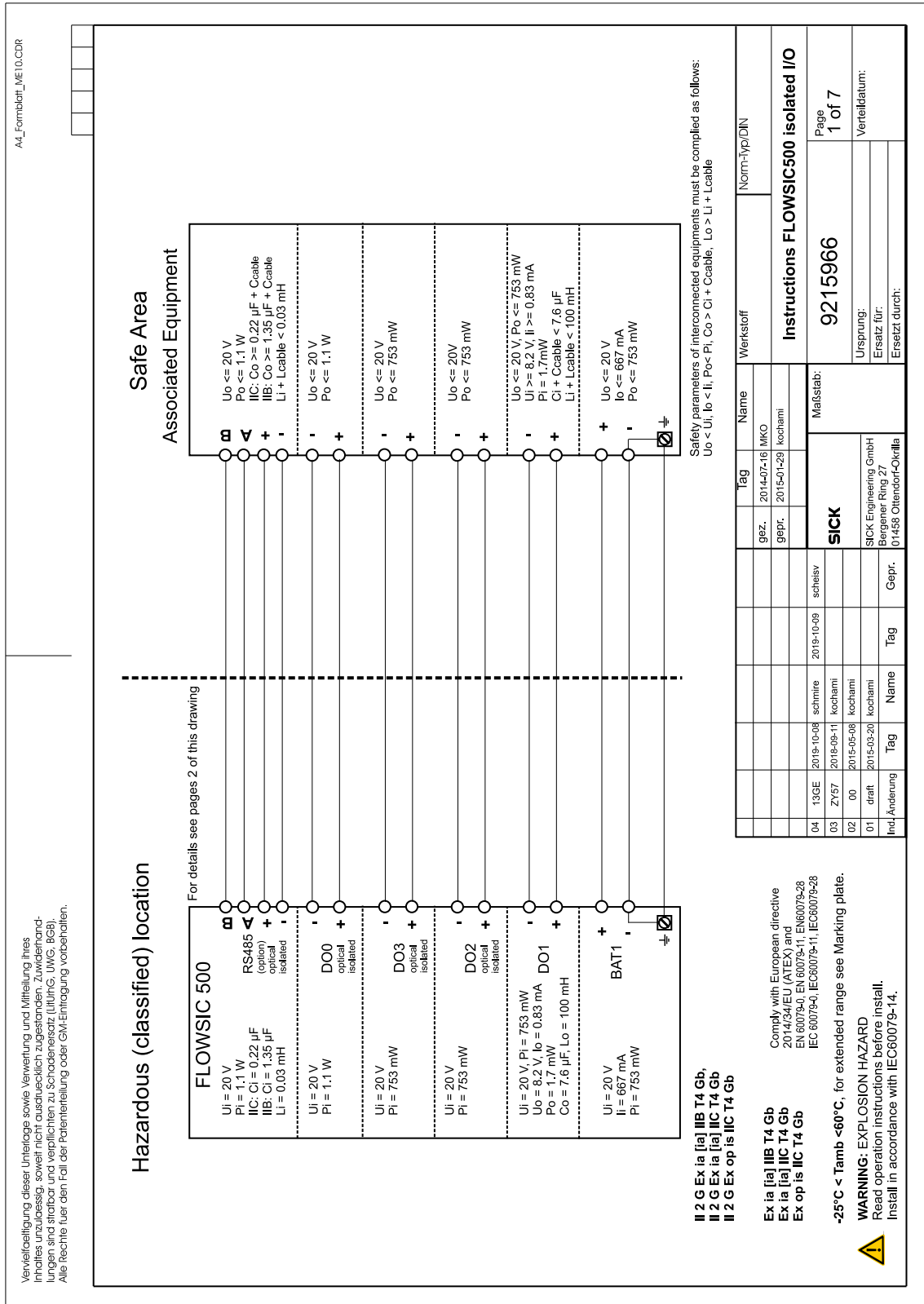
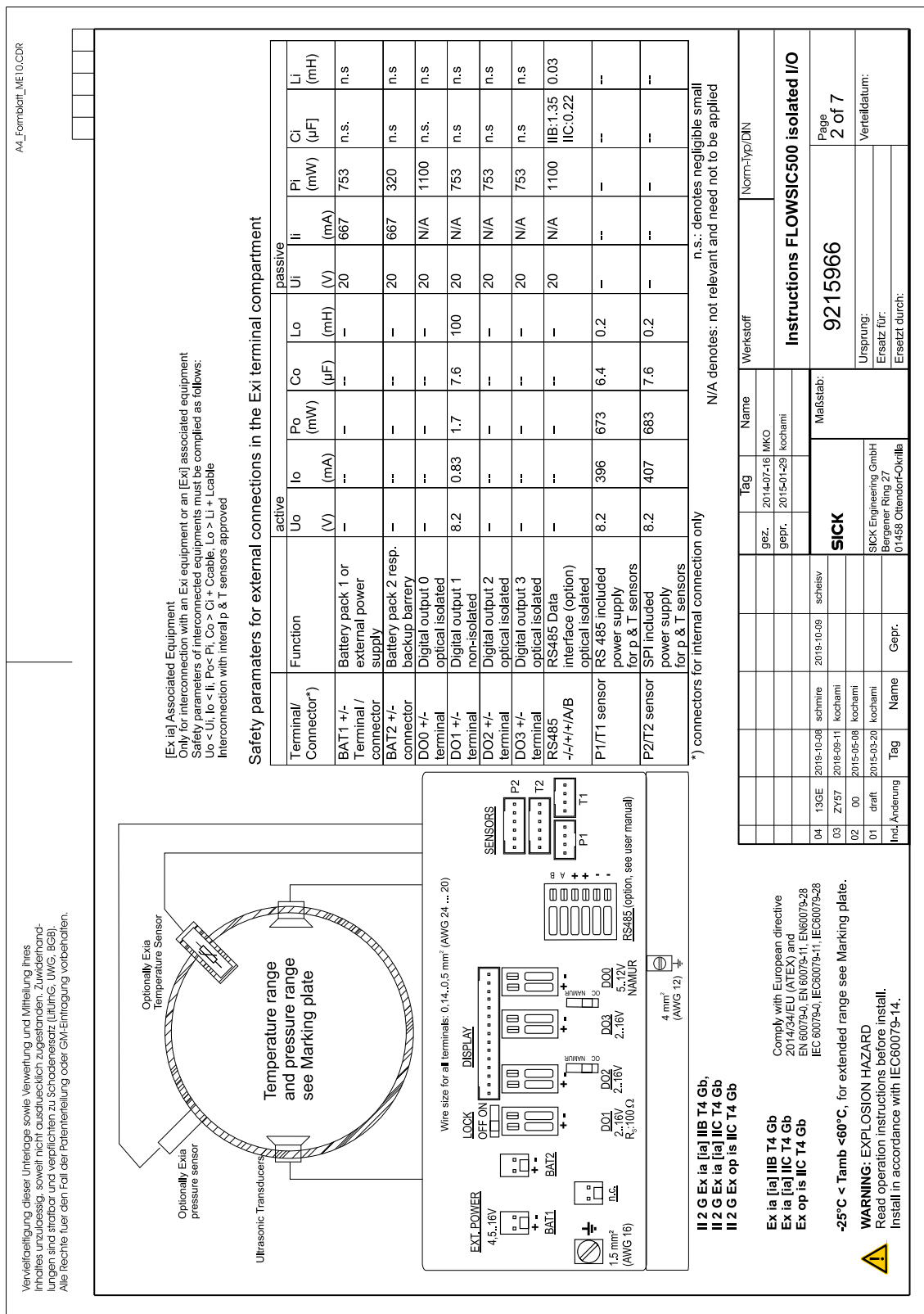

Fig. 83 Control diagram 9215966 (page 2)



Subject to change without notice

Fig. 84 Control diagram 9215966 (page 3)

Subject to change without notice

A4\_Formblatt\_ME10.CDR

**Pre-selected Configuration for circular connectors M12, male  
Configuration "2 Digital outputs LF"**

Page  
3 of 7

Optionally Exia Temperature Sensor

Optionally Exia pressure sensor

Ultrasonic Transducers

Temperature range and pressure range see Marking plate

| Connector.         | Function / signal            | Internal connection | Operating parameters                             | Safety parameters*)  |
|--------------------|------------------------------|---------------------|--|--|
| M12, male, B-coded |                              |                     |  |  |
| Pin 1              | ext. power supply "-" (GND)  | "BAT1 -" terminal   | nominal input voltage 4.5...16 V                 | Ui = 20 V<br>Ii = 667 mA<br>Pi = 753 mW                                |
| Pin 2              | ext. power supply "+"        | "BAT1 +" terminal   | passive, non-isolated, Low side switch max. 16 V | Uo = 8.2 V<br>Io = 0.83 mA<br>Po = 1.7 mW<br>Co = 7.6 µF<br>Lo = 100mH |
| Pin 3              | Digital output DO1 "-" (GND) | "DO1 -" terminal    |  |  |
| Pin 4              | Digital output DO1 "+"       | "DO1 +" terminal    |  |  |

| Configuration      | Operating parameters   | Safety parameters*)     |
|--------------------|--|-------------------------|
| M12, male, A-coded |  |                         |
| Pin 1              | passive, optically isolated  |                         |
| Pin 2              | max. 16 V  | Ui = 20 V<br>Pi = 753mW |
| Pin 3              | nom. 20 mA   |                         |
| Pin 4              | switchable as NAMUR nominal 8.2 V<br>Ion = 3.4 mA<br>Ioff = 0.7 mA |                         |

\*) values apply for the interconnection of all circuits within each connector

| Tag           | Name       | Werkstoff  | Norm-Typ/DIN |
|---------------|------------|------------|--------------|
| gez.          | 2014-07-16 | MKO        |              |
| gepr.         | 2015-01-29 | kochami    |              |
| <b>SICK</b>   |            |            |              |
| 04            | 13GE       | 2019-10-09 | schleiss     |
| 03            | ZY57       | 2016-09-11 | kochami      |
| 02            | 00         | 2015-05-08 | kochami      |
| 01            | draht      | 2015-03-20 | kochami      |
| Mod./Änderung | Tag        | Name       | Gepr.        |

Wire size for all terminals: 0,14...0,5 mm<sup>2</sup> (AWG 24 ... 20)

EXT-POWER 4,5...18V

LOCK OFF/ON

DISPLAY

BAT1

DO1 2,16V 2,16V R<sub>i</sub>:100Ω

DO2 2,16V 2,16V NAMUR

DO3 5,12V NAMUR

DO0

M12 4 mm<sup>2</sup> (AWG 12)

M12 DO2 + DO3

II 2 G Ex ia [ia] IIB T4 Gb,  
II 2 G Ex ia [ia] IIC T4 Gb  
II 2 G Ex op is IIC T4 Gb

Ex ia [ia] IIB T4 Gb  
Ex ia [ia] IIC T4 Gb  
Ex op is IIC T4 Gb

-25°C < Tamb < 60°C, for extended range see Marking plate.

**WARNING: EXPLOSION HAZARD**  
Read operation instructions before install.  
Install in accordance with IEC60079-14.

Fig. 85 Control diagram 9215966 (page 4)

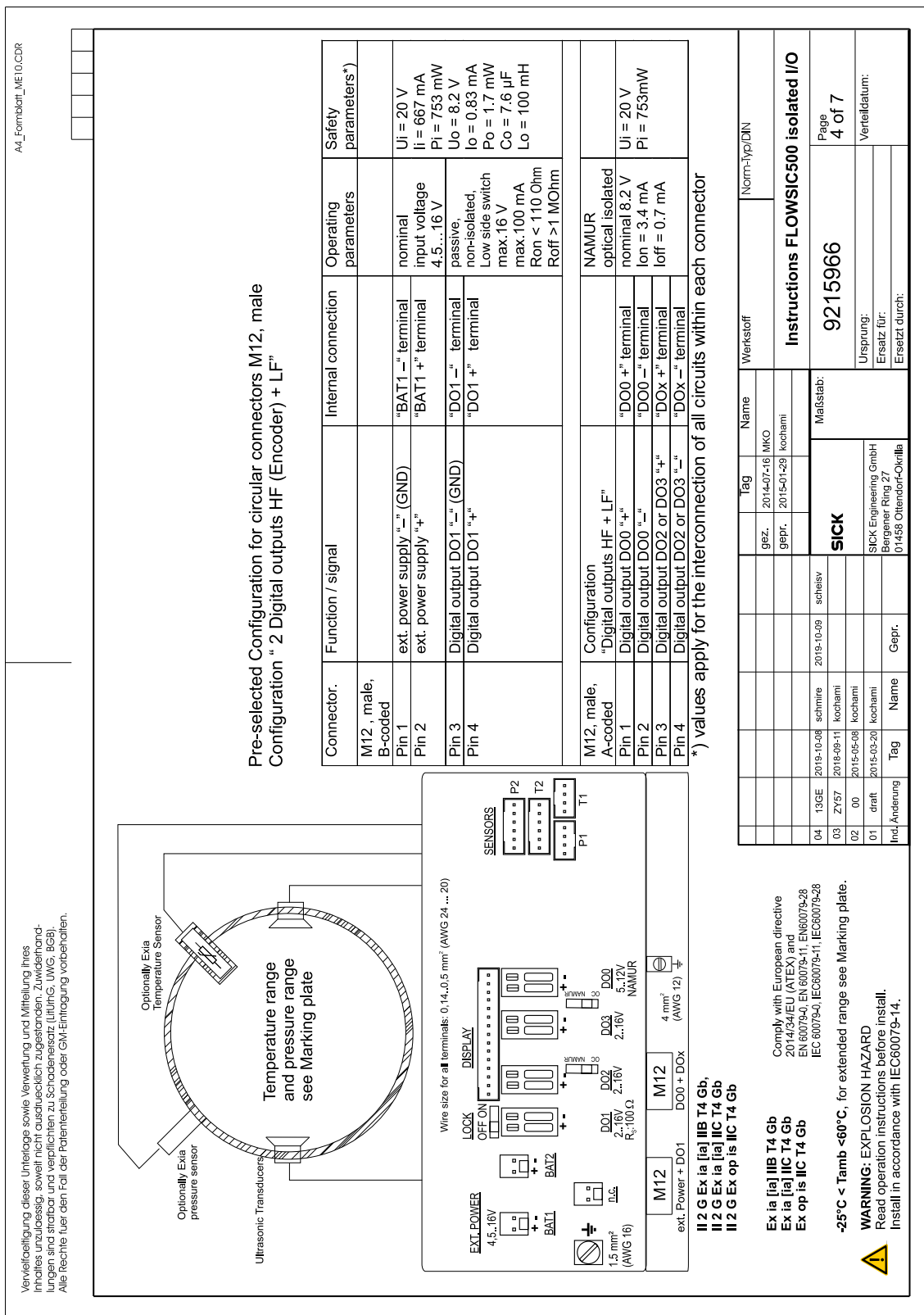

Subject to change without notice



Fig. 86 Control diagram 9215966 (page 5)

Subject to change without notice

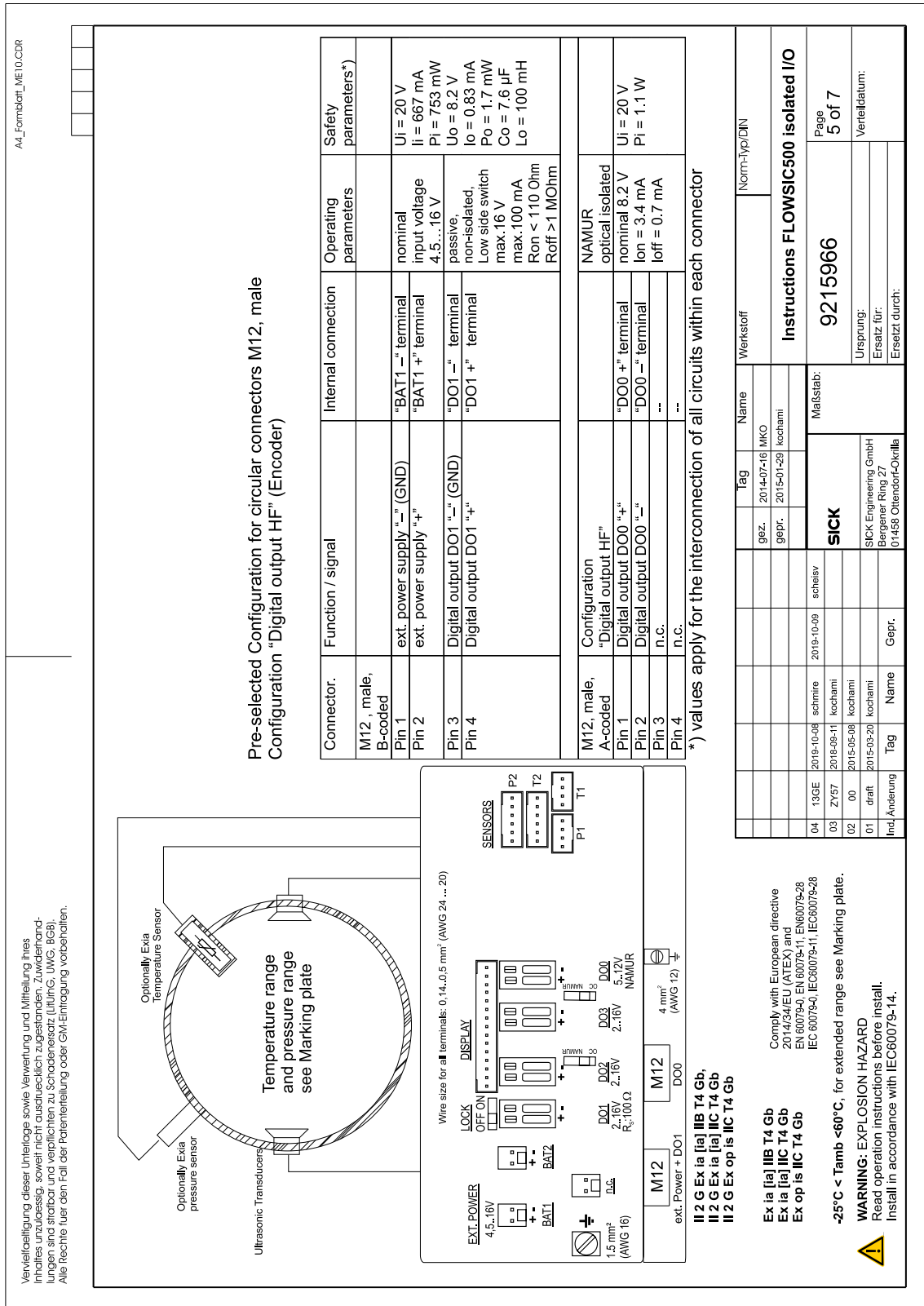

Fig. 87 Control diagram 9215966 (page 6)

A4\_Formblatt\_ME10.CDR

**Temperature range and pressure range see Marking plate**

Optionally Exia Temperature Sensor

Optionally Exia pressure sensor

Ultrasonic Transducers

SENSORS P2 T2 P1 T1

Wire size for all terminals: 0,14...0,5 mm<sup>2</sup> (AWG 24 ... 20)

EXT. POWER 4,5...16V

LOCK OFF ON

DISPLAY

BAT1

BAT2

DO1 2...16V 2...16V R<sub>i</sub>:100.Ω

DO2 2...16V

DO3 5...12V NAMUR

DO0

M12 1,5 mm<sup>2</sup> (AWG 16)

M12 ext. Power + DO1

M12 RS485 4 mm<sup>2</sup> (AWG 12)

Comply with European directive 2014/53/EU (ATEX) and EN60079-28 EN 60079-30, EN 60079-11, IEC60079-28 IEC 60079-30, IEC60079-11, IEC60079-28

**-25°C < Tamb < 60°C**, for extended range see Marking plate.

**WARNING: EXPLOSION HAZARD**  
Read operation instructions before install.  
Install in accordance with IEC60079-14.

**Pre-selected Configuration for circular connectors M12, male Configuration "RS485 external powered"**

| Connector.         | Function / signal                      | Internal connection | Operating parameters                            | Safety parameters*)   |
|--------------------|--|---------------------|---|---|
| M12, male, B-coded |  |                     |   |   |
| Pin 1              | ext. power supply "-" (GND)            | "BAT1 -" terminal   | nominal input voltage 4.5...16 V                | Ui = 20 V<br>Ii = 667 mA<br>Pi = 753 mW                                 |
| Pin 2              | ext. power supply "+"                  | "BAT1 +" terminal   |   | Uo = 8.2 V<br>Io = 0.83 mA<br>Po = 1.7 mW<br>Co = 7.6 µF<br>Lo = 100 mH |
| Pin 3              | Digital output DO1 "-" (GND)           | "DO1 -" terminal    | passive, non-isolated, Low side switch max.16 V |   |
| Pin 4              | Digital output DO1 "+"                 | "DO1 +" terminal    | max.100 mA<br>Ron < 110 Ohm<br>Roff > 1 MOhm    |   |
| M12, male, A-coded | Configuration "RS485 external powered" |                     | isolated  |   |
| Pin 1              | Auxiliary power supply input "+"       | "RS485 +" terminal  | nominal input voltage 2.7...5 V (LV)            | Ui = 20V<br>Pi = 1,1 W  |
| Pin 2              | "RS485_Data Interface "A"              | "RS485 A" terminal  |   | IIB: Ci = 1,35 µF   |
| Pin 3              | Auxiliary power supply input "-"       | "RS485 B" terminal  |   | IIC: Ci = 0,22 µF   |
| Pin 4              | RS485_Data Interface "B"               | "RS485 -" terminal  |   | Li = 0,03 mH  |

\*) values apply for the interconnection of all circuits within each connector

| Tag                     | Name       | Werkstoff | Norm-Typ/DIN |
|-------------------------|------------|-----------|--------------|
| gez.                    | 2014-07-16 | MKO       |              |
| gepr.                   | 2015-01-29 | kochami   |              |
| <b>SICK</b>             |            |           |              |
| Maßstab: <b>9215966</b> |            |           |              |
| Page <b>6 of 7</b>      |            |           |              |
| Verteildatum:           |            |           |              |
| Ursprung:               |            |           |              |
| Ersatz für:             |            |           |              |
| Ersetzt durch:          |            |           |              |

Fig. 88 Control diagram 9215966 (page 7)

Subject to change without notice

A4\_Formblatt\_ME10.CDR

Temperature range and pressure range see Marking plate

Ultrasonic Transducers

Wire size for all terminals: 0,14..0,5 mm<sup>2</sup> (AWG 24 ... 20)

LOCK OFF ON

EXT-POWER 4.5..18V

BATT

M12 1.5 mm<sup>2</sup> (AWG 16)

M12 4 mm<sup>2</sup> (AWG 12) e.g. DOx

M8 p & T

M8 p & T

SENSORS P2 T2 P1 T1

DISPLAY

DO1 2..16V 2..16V R<sub>i</sub>:100Ω

DO2 2..16V 2..16V NAMUR

DO3 5..12V NAMUR

DO4 2..16V 2..16V NAMUR

**Circular connectors M8, female for interconnection with external p & T sensors**

| Connector       | Function / signal          | internal Connection                    | Operating parameters         | Safety parameters*)  |
|-----------------|----------------------------|--|------------------------------|--|
| M8 (M12) female | p or T sensor              |  |                              |  |
| Pin 1           | PWR (power supply out "+") | "p & T sensor" 4-pole connector, coded | nominal output voltage 3.3 V | U <sub>o</sub> = 8.2 V<br>I <sub>o</sub> = 396 mA<br>P <sub>o</sub> = 673 mW<br>C <sub>o</sub> = 6.4 µF<br>L <sub>o</sub> = 0.2 mH |
| Pin 2           | DATA + (A)                 |  |                              |  |
| Pin 3           | GND (power supply out "-") |  |                              |  |
| Pin 4           | DATA - (B)                 |  |                              |  |
| M8 (M12) female | T or p sensor              |  |                              |  |
| Pin 1           | PWR (power supply +)       | "p & T sensor" 4-pole connector, coded | nominal output voltage 3.3 V | U <sub>o</sub> = 8.2 V<br>I <sub>o</sub> = 396 mA<br>P <sub>o</sub> = 673 mW<br>C <sub>o</sub> = 6.4 µF<br>L <sub>o</sub> = 0.2 mH |
| Pin 2           | DATA + (A)                 |  |                              |  |
| Pin 3           | GND (powersupply -)        |  |                              |  |
| Pin 4           | DATA - (B)                 |  |                              |  |

\*) values apply for the interconnection of all circuits within each connector

| Tag  | Name       | Werkstoff | Norm-Typ/DIN   |
|--|------------|-----------|----------------|
| gez.   | 2014-07-16 | MKO       |                |
| gepr.  | 2015-01-29 | kochami   |                |
| <b>Instructions FLOWSIC500 isolated I/O</b>                          |            |           |                |
| Maßstab:   |            |           | Page 7 of 7    |
| <b>SICK</b>  |            |           | Verteildatum:  |
| SICK Engineering GmbH<br>Bergener Ring 27<br>01458 Ottendorf-Okrilla |            |           | Ersatz für:    |
| 04 13GE 2019-10-09 schmitz   |            |           | Ersetzt durch: |
| 03 ZY57 2016-09-11 kochami   |            |           |                |
| 02 00 2015-05-08 kochami   |            |           |                |
| 01 draht 2015-03-20 kochami  |            |           |                |
| Mod./Änderung  | Tag        | Name      | Gepr.          |

**II 2 G Ex ia [ia] IIB T4 Gb,**  
**II 2 G Ex ia [ia] IIC T4 Gb**  
**II 2 G Ex op is IIC T4 Gb**

**Ex ia [ia] IIB T4 Gb**  
**Ex ia [ia] IIC T4 Gb**  
**Ex op is IIC T4 Gb**

**-25°C < Tamb < 60°C**, for extended range see Marking plate.

**WARNING: EXPLOSION HAZARD**  
 Read operation instructions before install.  
 Install in accordance with IEC60079-14.

|  |     |  |
|--|-----|--|
| <b>A</b>                               |     |  |
| Adapter                                | 17  |  |
| Additional documentation (information) | 14  |  |
| Assembly clearance                     | 54  |  |
| <b>C</b>                               |     |  |
| Calculation method                     | 25  |  |
| CE certificate                         | 132 |  |
| Certification                          | 132 |  |
| Clearing malfunctions                  | 93  |  |
| Combustible gas                        | 12  |  |
| Conformities                           | 132 |  |
| <b>D</b>                               |     |  |
| Designated users                       | 13  |  |
| <b>E</b>                               |     |  |
| Error messages                         | 77  |  |
| Event logbook                          | 23  |  |
| <b>F</b>                               |     |  |
| Flow direction                         | 40  |  |
| <b>I</b>                               |     |  |
| Icons (Explanation)                    | 3   |  |
| Ignitable gases                        | 12  |  |
| Information symbols                    | 3   |  |
| Intended use                           | 11  |  |
| - Designated users                     | 13  |  |
| - Restrictions of use                  | 12  |  |
| - User (target group)                  | 13  |  |
| <b>L</b>                               |     |  |
| Logbooks                               | 23  |  |
| <b>M</b>                               |     |  |
| Manufacturer                           | 11  |  |
| Measured values                        | 11  |  |
| Measuring function (general)           | 11  |  |
| Messages                               | 77  |  |
| Meter exchange                         | 99  |  |
| Metrology logbook                      | 23  |  |
| Minimes coupling                       | 27  |  |
| <b>O</b>                               |     |  |
| Overload protection                    | 135 |  |
| <b>P</b>                               |     |  |
| Parameter logbook                      | 23  |  |
| Plug-in connector cover                | 54  |  |
| Potentially explosive atmospheres      | 43  |  |
| Pressure measuring port                | 54  |  |
| Pressure sensor, external              | 26  |  |
| Pressure sensor, installation          | 54  |  |
| Pressure sensor, integrated            | 26  |  |
| Product identification                 | 11  |  |
| Product name                           | 11  |  |
| <b>R</b>                               |     |  |
| Reference potential                    | 54  |  |
| Replacement gas flow meter             | 114 |  |
| Responsibility of user                 | 13  |  |
| Restrictions of use                    | 12  |  |
| <b>S</b>                               |     |  |
| Safety information on subject          |     |  |
| - Electrical safety                    | 45  |  |
| Serial number                          | 11  |  |
| Signal words                           | 3   |  |
| <b>T</b>                               |     |  |
| Target group (user)                    | 13  |  |
| Temperature measuring port             | 54  |  |
| Temperature sensor, external           | 26  |  |
| Temperature sensor, installation       | 60  |  |
| Temperature sensor, integrated         | 26  |  |
| Three-way test valve                   | 27  |  |
| Totalizers                             | 22  |  |
| Type approval                          | 132 |  |
| Type code                              | 136 |  |
| Type plate                             | 11  |  |
| <b>U</b>                               |     |  |
| User                                   |     |  |
| - Designated users                     | 13  |  |
| - Responsibility of user               | 13  |  |
| <b>V</b>                               |     |  |
| Volume conversion                      | 25  |  |
| <b>W</b>                               |     |  |
| Warning symbols, warning levels        | 3   |  |



**Australia**

Phone +61 (3) 9457 0600  
1800 33 48 02 – tollfree  
E-Mail sales@sick.com.au

**Austria**

Phone +43 (0) 2236 62288-0  
E-Mail office@sick.at

**Belgium/Luxembourg**

Phone +32 (0) 2 466 55 66  
E-Mail info@sick.be

**Brazil**

Phone +55 11 3215-4900  
E-Mail comercial@sick.com.br

**Canada**

Phone +1 905.771.1444  
E-Mail cs.canada@sick.com

**Czech Republic**

Phone +420 234 719 500  
E-Mail sick@sick.cz

**Chile**

Phone +56 (2) 2274 7430  
E-Mail chile@sick.com

**China**

Phone +86 20 2882 3600  
E-Mail info.china@sick.net.cn

**Denmark**

Phone +45 45 82 64 00  
E-Mail sick@sick.dk

**Finland**

Phone +358-9-25 15 800  
E-Mail sick@sick.fi

**France**

Phone +33 1 64 62 35 00  
E-Mail info@sick.fr

**Germany**

Phone +49 (0) 2 11 53 010  
E-Mail info@sick.de

**Greece**

Phone +30 210 6825100  
E-Mail office@sick.com.gr

**Hong Kong**

Phone +852 2153 6300  
E-Mail ghk@sick.com.hk

**Hungary**

Phone +36 1 371 2680  
E-Mail ertekesites@sick.hu

**India**

Phone +91-22-6119 8900  
E-Mail info@sick-india.com

**Israel**

Phone +972 97110 11  
E-Mail info@sick-sensors.com

**Italy**

Phone +39 02 27 43 41  
E-Mail info@sick.it

**Japan**

Phone +81 3 5309 2112  
E-Mail support@sick.jp

**Malaysia**

Phone +603-8080 7425  
E-Mail enquiry.my@sick.com

**Mexico**

Phone +52 (472) 748 9451  
E-Mail mexico@sick.com

**Netherlands**

Phone +31 (0) 30 229 25 44  
E-Mail info@sick.nl

**New Zealand**

Phone +64 9 415 0459  
0800 222 278 – tollfree  
E-Mail sales@sick.co.nz

**Norway**

Phone +47 67 81 50 00  
E-Mail sick@sick.no

**Poland**

Phone +48 22 539 41 00  
E-Mail info@sick.pl

**Romania**

Phone +40 356-17 11 20  
E-Mail office@sick.ro

**Russia**

Phone +7 495 283 09 90  
E-Mail info@sick.ru

**Singapore**

Phone +65 6744 3732  
E-Mail sales.gsg@sick.com

**Slovakia**

Phone +421 482 901 201  
E-Mail mail@sick-sk.sk

**Slovenia**

Phone +386 591 78849  
E-Mail office@sick.si

**South Africa**

Phone +27 10 060 0550  
E-Mail info@sickautomation.co.za

**South Korea**

Phone +82 2 786 6321/4  
E-Mail infokorea@sick.com

**Spain**

Phone +34 93 480 31 00  
E-Mail info@sick.es

**Sweden**

Phone +46 10 110 10 00  
E-Mail info@sick.se

**Switzerland**

Phone +41 41 619 29 39  
E-Mail contact@sick.ch

**Taiwan**

Phone +886-2-2375-6288  
E-Mail sales@sick.com.tw

**Thailand**

Phone +66 2 645 0009  
E-Mail marcom.th@sick.com

**Turkey**

Phone +90 (216) 528 50 00  
E-Mail info@sick.com.tr

**United Arab Emirates**

Phone +971 (0) 4 88 65 878  
E-Mail contact@sick.ae

**United Kingdom**

Phone +44 (0)17278 31121  
E-Mail info@sick.co.uk

**USA**

Phone +1 800.325.7425  
E-Mail info@sick.com

**Vietnam**

Phone +65 6744 3732  
E-Mail sales.gsg@sick.com

Detailed addresses and further locations at [www.sick.com](http://www.sick.com)